

# WORKZONE®



## 14.4 V Lithium-Ion Cordless Drill

### USER GUIDE

Now you have purchased a Workzone® product you can rest assured in the knowledge that as well as your 3 year parts and labour guarantee you have the added peace of mind of dedicated helplines and web support.

#### AFTER SALES SUPPORT



0151 649 1500  
(Charged at local rates)



[www.einhell.co.uk](http://www.einhell.co.uk)

1890 946 6244

WZAS 14,4 Li

XI/20/2011



Congratulations!

You have made an excellent choice with the purchase of this quality Workzone® product.

By doing so you now have the assurance and peace of mind which comes from purchasing a product that has been manufactured to the highest standards of performance and safety, supported by the high quality standards of ALDI.

We want you to be completely satisfied with your purchase so this Workzone® product is backed by a comprehensive manufacturer's 3 year warranty and an outstanding after sales service through our dedicated Helpline.

We hope you will enjoy using your purchase for many years to come.

If you require technical support or in the unlikely event that your purchase is faulty please telephone our Helpline for immediate assistance. Faulty product claims made within the 3 year warranty period will be repaired or replaced free of charge provided that you have satisfactory proof of purchase (keep your till receipt safe!). This does not affect your statutory rights. However, be aware that the warranty will become null and void if the product is found to have been deliberately damaged, misused or disassembled.





# Table of contents

<b>04</b>	Safety information
<b>14</b>	Items supplied
<b>15</b>	Layout
<b>16</b>	Use
<b>17</b>	Before putting into operation
<b>18</b>	Operation
<b>23</b>	Information
<b>29</b>	Guarantee Certificate





# Safety information

# 1

## General safety information for power tools

### **Important.**

When using equipment, a few safety precautions must be observed to avoid injuries and damage. Please read the complete operating instructions and safety information with due care. Keep these operating instructions in a safe place so that the information is available at all times. If you give the equipment to any other person, hand over these operating instructions and the safety information as well. We cannot accept any liability for damage or accidents which arise due to a failure to follow these instructions and the safety information.

### **Important.**

Read all the safety regulations and instructions. Any errors made in following the safety information and instructions set out below may result in an electric shock, fire and/or serious injury.

**Keep all safety information and instructions in a safe place for future use.**

The term „power tool“ used in the safety regulations refers to power tools operated from the mains power supply (with a power cable) and to battery operated power tools (without a power cable).

### **1. Workplace safety**

- **Keep your work area clean and well lit.** Untidy or unlit work areas can result in accidents.
- **Do not use this power tool in an area where there is a risk of explosion and where there are inflammable liquids, gases or dust.** Power tools generate sparks that can ignite dust or vapors.
- **Keep children and other people away from the power tool while you are using it.** If you are distracted you may lose control of the tool.





## 2. Electrical safety

- **The plug on the power tool must fit into the socket. The socket must not be modified in any way. Do not use adapter plugs together with power tools with a protective earth.** Unmodified plugs and matching sockets will reduce the risk of an electric shock.
- **Avoid body contact with earthed surfaces such as pipes, heating systems, stoves and refrigerators.** There is an increased risk of suffering an electric shock if your body is earthed.
- **Keep the power tool out of the rain and away from moisture.** The ingress of water into an electric power tool increases the risk of an electric shock.
- **Do not use the cable for a purpose for which it is not designed, for example to carry the power tool, hang it up or to pull the plug out of the socket. Keep the cable away from heat, oil, sharp edges or moving parts of the tool.** Cables that are damaged or tangled increase the risk of an electric shock.
- **If you use an electric power tool outdoors, use only extension cables that are suitable for outdoor use.** The use of an extension cable which is suitable for outdoor use reduces the risk of an electric shock.
- **If you cannot avoid using the power tool in a damp location, use a residual current device (RCD) circuit breaker.** The use of a residual current device (RCD) circuit breaker will reduce the risk of suffering an electric shock.

## 3. Safety of persons

- **Be careful, watch what you are doing and be sensible and responsible when using an electric power tool. Never use the power tool if you are tired or under the influence of drugs, alcohol or medication.** One moment of inattention when using the electric tool can result in serious injuries.
- **Wear personal safety equipment and always wear safety goggles.** Wearing personal safety equipment such as dust masks, non-slip safety shoes, a helmet or ear plugs, depending on the type and application of the tool, reduces the risk of injury.
- **Make sure that the tool cannot start up accidentally.** Ensure that the power tool is switched off before you connect it to the power supply and/or connect the battery pack, pick it up or carry it. If you have your





finger on the switch while carrying the power tool or if you connect the tool to the power supply while it is switched on, this may cause accidents.

- **Remove all adjusting tools or wrenches before you switch on the power tool.** Any tool or wrench in a rotating part of the tool could cause injuries.
- **Avoid abnormal working postures. Make sure you stand squarely and keep your balance at all times.** This will enable you to control the power tool better in unexpected situations.
- **Wear suitable clothes. Never wear loose fitting clothes or jewelry.** Keep hair, clothing and gloves away from moving parts. Loose clothing, jewelry or long hair can be caught by moving parts.
- **If you can fit dust extraction devices and dust collection devices to the tool, ensure that they are correctly connected and used for the correct purposes.** The use of a dust extractor can reduce the dangers posed by dust.

#### 4. Using and handling the power tool

- **Do not overload the equipment. Use the correct electric tool for the job in hand.** The correct tool will enable you to work better and more safely within the specific performance range.
- **Do not use an electric power tool if the switch is defective.** An electric power tool that cannot be switched on or off is dangerous and must be repaired.
- **Pull the plug out of the socket and/or remove the battery pack before making any adjustments to the tool, changing accessories or putting the tool down.** These precautions will prevent the power tool starting accidentally.
- **Keep unused electric tools out of the reach of children. Do not allow people who are not familiar with the tool or who have not read these instructions to use the tool.** Electric tools are dangerous if they are used by inexperienced people.
- **Look after power tools with care. Check that moving parts function correctly and do not jam, and whether any parts are broken or damaged such that they adversely affect the function of the power tool. Have damaged parts repaired before you use the tool.** Many accidents are caused by poorly maintained electric tools.





- **Keep your cutting tools sharp and clean.** Carefully maintained cutting tools with sharp cutting edges will jam less and are easier to control.
- **Use the power tool, accessory plug-in tools, etc. as set out in these instructions. Take the conditions in your work area and the job in hand into account.** Using electric tools for purposes other than the one for which they are designed can result in dangerous situations.

### 5. Using and handling the cordless tool

- **Only charge the batteries in chargers that are recommended by the manufacturer.** A charger that is designed for a certain type of battery may pose a fire risk if it is used with other types of battery.
- **Use only the correct batteries in the electric tools.** The use of other batteries may result in injuries and a fire risk.
- **Keep unused batteries away from paper clips, coins, keys, nails, screws and other metallic objects that could cause a short circuit between the contacts.** A short circuit between the battery contacts may cause burns or a fire.
- **In case of incorrect use, fluid may escape from the battery. Avoid contact with it. If you touch it by accident, rinse the affected area with water. If you get the fluid in your eyes, also seek medical advice.** Leaking battery fluid can cause skin irritation or burns.

### 6. Service

- **Have your power tool repaired only by trained personnel using only genuine spare parts.** This will ensure that your power tool remains safe to use.

### Safety information for drills

- **Wear ear plugs when using hammer drills.** The impact of noise can cause damage to hearing.
- **Use the additional handles supplied with the tool.** Losing control of the machine can cause injuries.

**Hold the equipment by the insulated handles when carrying out work during which the screw or the plug-in tool could strike concealed power cables.** Contact with a live cable may also make the metal parts of the equipment live and cause an electric shock.





## Additional safety instructions

We pay a great deal of attention to the design of every battery pack to ensure that we supply you with batteries which feature maximum power density, durability and safety. The battery cells have a wide range of safety devices. Each individual cell is initially formatted and its electrical characteristic curves are recorded. These data are then used exclusively to be able to assemble the best possible battery packs. **Despite all the safety precautions, caution must always be exercised when handling batteries. The following points must be obeyed at all times to ensure safe use.**

**Safe use can only be guaranteed if undamaged cells are used. Incorrect handling can cause cell damage.**

### **Important.**

Analyses confirm that incorrect use and poor care are the main causes of the damage caused by high performance batteries.

### **Information about the battery**

- **Ensure that the equipment is switched off before you insert the battery.** Inserting a battery into an electric tool that is switched on can cause accidents.
- The battery pack supplied with your cordless tool is not charged. The battery pack has to be charged before you use the tool for the first time.
- For optimum battery performance avoid low discharge cycles. Charge the battery pack frequently.
- Store the battery pack in a cool place, ideally at 15°C and charged to at least 40%.
- Lithium-ion batteries are subject to a natural ageing process. The battery pack must be replaced at the latest when its capacity falls to just 60% of its capacity when new. Weakened cells in an aged battery pack are no longer capable of meeting the high power requirements and therefore pose a safety risk.
- Do not throw battery packs into an open fire. There is a risk of explosion!
- Do not ignite the battery pack or expose it to fire.







- **Do not exhaustively discharge batteries.**  
Exhaustive discharge will damage the battery cells. The most common cause of exhaustive discharge is lengthy storage or non-use of partly discharged batteries. Stop working as soon as the performance of the battery falls noticeably or the electronic protection system triggers. Place the battery pack in storage only after it has been fully charged.
- **Protect batteries and the tool from overloads.**  
Overloads will quickly result in overheating and cell damage inside the battery housing without this overheating actually being apparent externally.
- **Avoid damage and shocks.**  
Replace batteries which have been dropped from a height of more than one meter or which have been exposed to violent shocks without delay, even if the housing of the battery pack appears to be undamaged. The battery cells inside the battery may have suffered serious damage. In this respect, please also read the waste disposal information.
- If the battery pack suffers overloading and overheating, the integrated protective cut-off will switch off the equipment for safety reasons. **Important!** Do not press the ON/OFF switch any more if the protective cut-off has actuated. This may damage the battery.
- Use only original battery packs. The use of other batteries may result in injuries, explosion and a fire risk.

#### Information on chargers and the charging process

- **Important.** The charging of NON-rechargeable batteries is prohibited.
- This equipment is not designed to be used by people (including children) with limited physical, sensory or mental capacities or those with no experience and/or knowledge unless they are supervised by a person who is responsible for their safety or they have received instructions from such a person in how to use the equipment safely. Children must always be supervised in order to ensure that they do not play with the equipment.
- Please check the data marked on the rating plate of the battery charger. Be sure to connect the battery charger to a power supply with the voltage marked on the rating plate. Never connect it to a different mains voltage.





- Protect the battery charger and its cable from damage and sharp edges. Have damaged cables repaired without delay by a qualified electrician.
- Keep the battery charger, batteries and the cordless tool out of children's reach.
- Do not use damaged battery chargers.
- Do not use the supplied battery charger to charge other cordless tools.
- In heavy use the battery pack will become warm. Allow the battery pack to cool to room temperature before commencing with the charging.
- **Do not over-charge batteries.**  
Do not exceed the maximum charging times. These charging times apply only to discharged batteries. Frequent insertion of a charged or partly charged battery pack will result in over-charging and cell damage. Do not leave batteries in the charger for days on end.
- **Never use or charge batteries if you suspect that the last time they were charged was more than 12 months previously.** There is a high probability that the battery pack has already suffered dangerous damage (exhaustive discharge).
- Charging batteries at a temperature below 10°C will cause chemical damage to the cell and may cause a fire.
- Do not use batteries which have heated during the charging process, as the battery cells may have suffered dangerous damage.
- Do not use batteries which have suffered curvature or deformation during the charging process or which show other non-typical symptoms (gassing, hissing, cracking,...)
- Never fully discharge the battery pack (recommended depth of discharge max. 80%) A complete discharge of the battery pack will lead to premature ageing of the battery cells.
- Never charge the batteries unsupervised.





### Protection from environmental influences

- Wear suitable work clothes. Wear safety goggles.
- Protect your cordless tool and the battery charger from moisture and rain. Moisture and rain can cause dangerous cell damage.
- Do not use the cordless tool or the battery charger near vapors and inflammable liquids.
- Use the battery charger and cordless tools only in dry conditions and an ambient temperature of 10-40°C.
- Do not keep the battery charger in places where the temperature is liable to reach over 40°C. In particular, do not leave the battery charger in a car that is parked in the sunshine.
- **Protect batteries from overheating.** Overloads, over-charging and exposure to direct sunlight will result in overheating and cell damage. Never charge or work with batteries which have been overheated – replace them immediately if possible.
- **Storage of batteries, battery chargers and cordless tools.** Store the charger and your cordless tool only in dry places with an ambient temperature of 10-40°C. Store your lithium-ion battery pack in a cool, dry place at a temperature of 10-20°C. Protect from humidity and direct sunlight. Place only fully charged batteries in storage (charged at least 40%).
- Prevent the lithium-ion battery pack from freezing. Battery packs which were stored below 0°C for more than 60 minutes must be disposed of.
- When handling batteries beware of electrostatic charge: Electrostatic discharges cause damage of the electronic protection system and the battery cells. Avoid electrostatic charging and never touch the battery poles.

**Do not lose this safety information.**



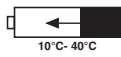

The battery should be charged only at a temperature between 10°C and 40°C.



To avoid causing damage to the gearing, change the gear only when the equipment is at a standstill.

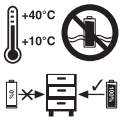

Store the battery only in dry rooms with an ambient temperature of +10°C to +40°C. Place only charged batteries in storage (charged at least 40%).





**„WARNING - Read the operating instructions in order to reduce the risk of injury“**



**Wear ear-muffs.**

The impact of noise can cause damage to hearing.



**Wear safety goggles.**

Sparks generated during work or splinters, chips and dust emitted by the equipment can cause loss of sight.



**Wear a breathing mask.**

Dust which is injurious to health can be generated when working on wood and other materials. Never use the tool to work on any materials containing asbestos!





# Items supplied

# 2

- Open the packaging and take out the equipment with care.
- Remove the packaging material and any packaging and/or transportation braces (if available).
- Check to see if all items are supplied.
- Inspect the equipment and accessories for transport damage.
- If possible, please keep the packaging until the end of the guarantee period.

## Important!

The equipment and packaging material are not toys. Do not let children play with plastic bags, foils or small parts. There is a danger of swallowing or suffocating!

- Cordless drill/screwdriver
- Battery charger
- 8 drill bits
- 8 screwdriver bits
- Original operating instructions





# Layout

# 3

1. Torque selector
2. Quick-change drill chuck
3. Changeover switch
4. ON/OFF switch
5. Battery
6. Battery charger
7. Selector switch for 1st/2nd gear
8. Pushlock button
9. LED light
10. Battery capacity indicator

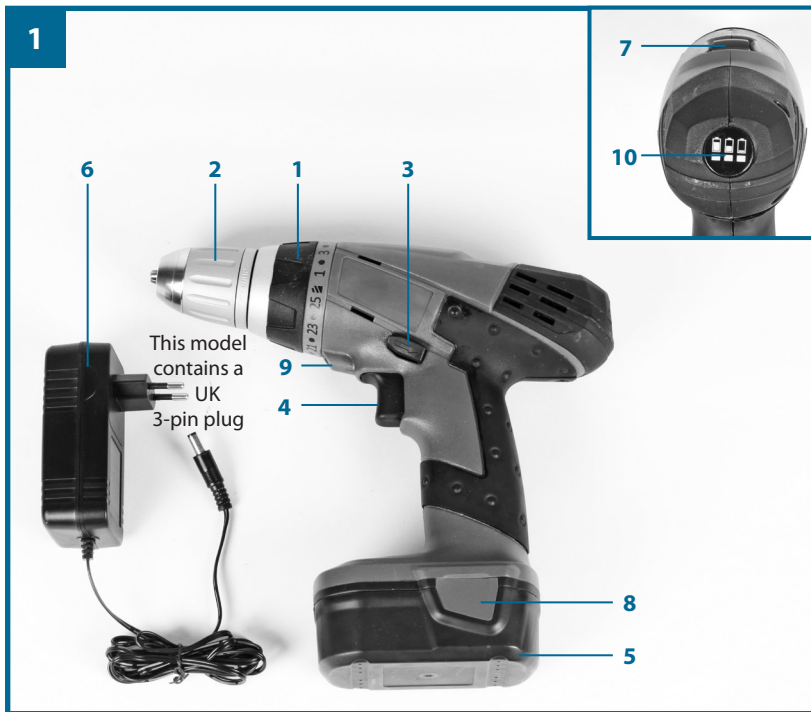



# Use

# 4

The cordless drill/screwdriver is designed for tightening and undoing screws, as well as for drilling in wood, metal and plastic.

The equipment is to be used only for its prescribed purpose. Any other use is deemed to be a case of misuse. The user/operator and not the manufacturer will be liable for any damage or injuries of any kind caused as a result of this.

Please note that our equipment has not been designed for use in commercial, trade or industrial applications. Our warranty will be voided if the equipment is used in commercial, trade or industrial businesses or for equivalent purposes.







## Before putting into operation

# 5

Be sure to read the following information before you put the cordless screwdriver into operation:

1. Charge the battery pack only with the charger supplied.
2. Only ever use sharp drill bits and screwdriver bits which are suitable for the purpose and in faultless condition.
3. Always check for concealed electric cables and gas and water pipes when drilling and screwing in walls.



# Operation

# 6

## Charging the battery (Fig. 2-3)

Important! At below 10° C, charging is reduced in keeping with the charger's intelligent safety concept. This may mean that the battery pack will not be fully charged. At below 0° C and above 40° C there is no charging performed.

The battery is protected from exhaustive discharge. An integrated protective circuit automatically switches off the equipment when the battery is flat. In this case the bit chuck will cease to turn. **Warning! Do not press the ON/OFF switch any more if the protective circuit has actuated. This may damage the battery.**

1. Take the rechargeable battery pack out of the handle (Fig. 2), pressing the pushlock buttons (8) at the side to do so. It is also possible however for the battery to be charged when left in the equipment.
2. Check that your mains voltage is the same as that marked on the rating plate of the battery charger. Plug the battery charger in the plug socket and connect the charging cable (b) to the charging connection (Fig. 3). The charging process starts as soon as the charging cable is connected to the charging connection.
3. The flashing of the green LED (a) indicates that the battery is being charged.
4. When charging is finished, the green LED (a) lights up continuously. There is no risk in leaving the battery in the charger as the charging is ended automatically. However, you should disconnect the charger from the battery and from the power supply so as not to waste electricity.

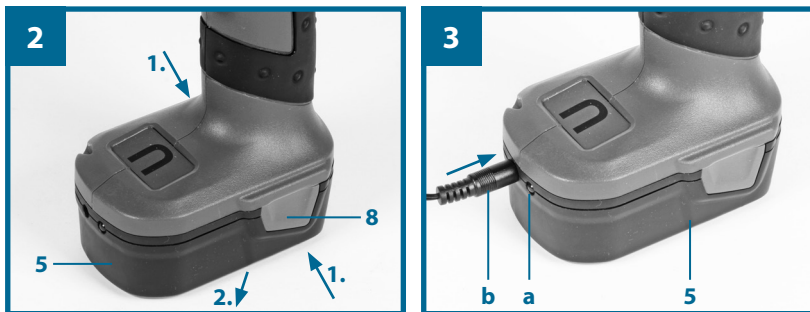



If the battery pack fails to charge, check for the following:

- Voltage at the socket-outlet
- Proper contact at the charging contacts in the battery charger

If the battery pack still fails to charge, send

- the battery charger
- and the battery pack to our customer services department.

To ensure that the battery pack provides long service, you should take care to recharge it promptly. You must recharge the battery pack when you notice that the power of the cordless equipment drops.

### Torque setting (Fig. 4/Item 1)

The cordless screwdriver is fitted with a mechanical torque selector.

The torque for each screw size is set with the setting ring (1). The torque is dependent on a number of factors:

- On the type and hardness of the material involved
- On the type and length of the screws used
- On the requirements that the screw connection has to satisfy

The grating disengagement of the coupling indicates that the selected torque level has been reached.

**Important! Only ever adjust the setting ring when the equipment is at a standstill.**

### Drilling (Fig. 4/Item 1)

For drilling adjust the setting ring for the torque to the last setting "Drill". In this drill setting the slip coupling is non-functional. The maximum torque is available for drilling.





#### 6.4 Changeover switch (Fig. 5/Item 3)

The slide switch above the ON/OFF switch is for setting the direction of rotation of the cordless screwdriver and for preventing the cordless screwdriver from being switched on inadvertently. You can select between clockwise and counter-clockwise rotation. To avoid causing damage to the gearing, the direction of rotation must only be changed when the screwdriver is at a standstill. When the slide switch is in the middle position, the ON/OFF switch is blocked.

#### 6.5 ON/OFF switch (Fig. 5/Item 4)

Infinitely variable speed control is possible with the ON/OFF switch. The further you push the switch, the higher the speed of the cordless screwdriver.

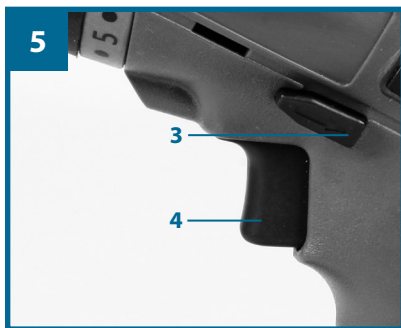

#### 6.6 Battery capacity indicator (Fig. 1/Item 10)

Press the ON/OFF switch (4). The battery capacity indicator (10) indicates the charge state of the battery on 3 colored LEDs.

##### All the LEDs are lit:

The battery is fully charged.

##### The yellow and red LEDs are lit:

The battery has an adequate remaining charge.

##### Red LED:

The battery is empty, recharge the battery.





### 6.7 Changing the tool (Fig. 6)

Important. Set the changeover switch (3) to its centre position whenever you carry out any work (for example changing the tool, maintenance work, etc.) on the cordless screwdriver.

- The cordless screwdriver is fitted with a quick-action chuck (2) with an automatic spindle stop.
- Turn the chuck (2) counter-clockwise so that it opens.
- The chuck opening (a) must be large enough to hold the tool (drill bit or screwdriver bit).
- Select the suitable tool. Push the tool as far as possible into the chuck opening (a).
- Turn the chuck (2) counter-clockwise so that it closes tightly and then check that the tool is secure.

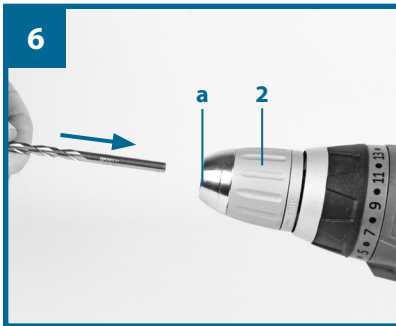

### 6.8 Screwing

It is advisable to use self-centering screws (e.g. Torx, cross recessed head) as these will enable you to work safely and reliably. Always make sure that the bit used is of the same size and shape as the screw. Set the torque to suit the screw size as specified in the instructions.





### 6.9 LED lamp (Fig. 1/Item 9)

The LED lamp (9) can be used to additionally illuminate the area where you want to screw or drill.

The LED lamp (9) will be lit automatically as soon as you press the ON/OFF switch (4).

### 6.10 Switching between speed 1 and speed 2 (Fig. 4/Item 7)

You can work with a higher or lower speed depending on the position of the selector switch. Change the gear only when the drill is at a standstill. If you fail to observe this point, the gearing may be damaged.



# Information

# 7

## Cleaning, maintenance and ordering of spare parts

Always pull out the power plug before starting any cleaning work.

### Cleaning

- Keep all safety devices, air vents and the motor housing free of dirt and dust as far as possible. Wipe the equipment with a clean cloth or blow it down with compressed air at low pressure.
- We recommend that you clean the equipment immediately after you use it.
- Clean the equipment regularly with a damp cloth and some soft soap. Do not use cleaning agents or solvents; these may be aggressive to the plastic parts in the equipment. Ensure that no water can get into the interior of the equipment.

### Maintenance

There are no parts inside the equipment which require additional maintenance.

### Ordering spare parts

Please provide the following information on all orders for spare parts:

- Model/type of the equipment
- Article number of the equipment
- ID number of the equipment
- Spare part number of the required spare part

For our latest prices and information please go to [www.isc-gmbh.info](http://www.isc-gmbh.info)

Item	Description	Replacement part no.
05	Battery	45.133.16.01.001
06	Battery charger	45.133.16.01.002
02	Drill chuck	45.133.16.01.003
04	ON/OFF switch	45.133.16.01.004



### Disposal and recycling

The equipment is supplied in packaging to prevent it from being damaged in transit. The raw materials in this packaging can be reused or recycled. The equipment and its accessories are made of various types of material, such as metal and plastic. Defective components must be disposed of as special waste. Ask your dealer or your local council.

**Refer to the additional information on page 27.**

### Storage

Store the equipment and accessories out of children's reach in a dark and dry place at above freezing temperature. The ideal storage temperature is between 5 and 30 °C. Store the electric tool in its original packaging.

### Technical data

Motor power supply: ..... 14.4 V DC  
 Idling speed: ..... 0-400/0-1150 rpm  
 Torque settings: ..... 25+1  
 Clockwise/counter-clockwise: ..... Yes  
 Drill chuck clamping range: ..... 0.8 mm-10 mm  
 Rated battery capacity: ..... 1.3 Ah  
 Battery charge voltage: ..... 18 V DC  
 Battery charge current: ..... 1.3 A  
 Charger supply voltage: ..... 100-240 V ~ 50-60 Hz  
 Charging time: ..... max. 1 hour  
 Battery type: ..... Lithium-ion  
 Weight: ..... 1.4 kg  
 Screw diameter: ..... 6 mm







### Sound and vibration

Sound and vibration values were measured in accordance with EN 60745.

$L_{pA}$ sound pressure level .....	67 dB(A)
$K_{pA}$ uncertainty .....	4 dB
$L_{WA}$ sound power level .....	78 dB(A)
$K_{WA}$ uncertainty .....	4 dB

### Wear ear-muffs.

The impact of noise can cause damage to hearing.

Total vibration values (vector sum of three directions) determined in accordance with EN 60745.

### Drilling in metal

Vibration emission value  $a_h \leq 2.5 \text{ m/s}^2$

K uncertainty =  $1.5 \text{ m/s}^2$

### Screwing without hammer action

Vibration emission value  $a_h \leq 2.5 \text{ m/s}^2$

K uncertainty =  $1.5 \text{ m/s}^2$

### Additional information for electric power tools

#### Warning!

The specified vibration value was established in accordance with a standardized testing method. It may change according to how the electric equipment is used and may exceed the specified value in exceptional circumstances.





The specified vibration value can be used to compare the equipment with another electric power tool.

The specified vibration value can be used for initial assessment of a harmful effect.

### **Reduce noise generation and vibration to a minimum!**

- Use only equipment that is in perfect condition.
- Maintain and clean the equipment regularly.
- Adopt your way of working to the equipment.
- Do not overload the equipment.
- Have the equipment checked if necessary.
- Switch off the equipment when not in use.
- Wear gloves.

### **Residual risks**

Even if you use this electric power tool in accordance with the instructions, certain residual risks cannot be eliminated. The following hazards may arise in connection with the equipment's construction and layout:

1. Lung damage if no suitable protective dust mask is used.
2. Damage to hearing if no suitable ear protection is applied.
3. Health damage caused by hand-arm vibrations if the equipment is used over a longer period or is not properly guided and maintained.



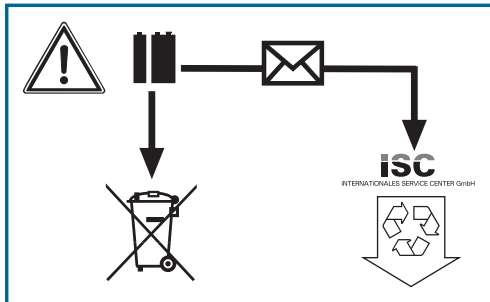

Rechargeable batteries and cordless electric machines and tools contain materials that are potentially harmful to the environment. Never place any cordless electric machines or tools in your household refuse. When cordless electric machines or tools become defective or worn, remove the rechargeable batteries and return them to iSC GmbH (address: Eschenstrasse 6, D-94405, Germany). If the rechargeable batteries cannot be removed, return the complete cordless machine or tool. You can then be sure that the equipment will be correctly disposed of by the manufacturer.

**When shipping or disposing of batteries and cordless tools, always ensure that they are packed individually in plastic bags to prevent short circuits and fires.**



For EU countries only



Never place any electric power tools in your household refuse.

To comply with European Directive 2002/96/EC concerning old electric and electronic equipment and its implementation in national laws, old electric power tools have to be separated from other waste and disposed of in an environment-friendly fashion, e.g. by taking to a recycling depot.

Recycling alternative to the return request: Instead of returning the equipment to the manufacturer, the owner of the electrical equipment is obliged to ensure that the equipment is properly disposed of if he abandons ownership. The old equipment can be returned to a suitable collection point that will dispose of the equipment in accordance with the national recycling and waste disposal regulations. This does not apply to any accessories or aids without electrical components supplied with the old equipment.





The reprinting or reproduction by any other means, in whole or in part, of documentation and papers accompanying products is permitted only with the express consent of the ISC GmbH.

Subject to technical changes.

This consignment contains lithium-ion batteries. In accordance with special provision 188 this consignment is not subject to the ADR regulations. Handle with care. Danger of ignition in case of damage to the consignment package. If the consignment package is damaged: Check and if necessary repackage.

For further information contact: 0049 1805 / 687486 (fixed network 14 ct/min; mobile phone max. 42 ct/min). Outside Germany charges will apply instead for a regular call to a landline number in Germany.





# Guarantee Certificate **8**

Dear Customer,

XI/20/2011

All of our products undergo strict quality checks to ensure that they reach you in perfect condition. In the unlikely event that your cordless drill/screwdriver develops a fault, please contact our service department at the address shown on this guarantee card. You can also contact us by telephone using the service number shown below. Please note the following terms under which guarantee claims can be made:

1. Our guarantee covers only problems caused by material or manufacturing defects, and it is restricted to the rectification of these defects or the replacement of the equipment. It does not cover replacement work for transport damage, damage caused by failure to follow the assembly and operating instructions, damage through misuse or incorrect applications, damage caused by failure to follow the maintenance and safety instructions, damage resulting from the use of force and external effects, or the normal wear and tear which arises during the proper use of the product.

The guarantee is rendered null and void if any attempt is made to tamper with the equipment.

2. No guarantee claims will be accepted after the end of the guarantee period. This also applies if an on-site service is used.

The guarantee is valid for a period of three years starting from the purchase date. Keep your sales receipt in a safe place, as it is your proof of purchase.

Your statutory rights are not affected by this guarantee. During the guarantee period you can report defective equipment by phone or by writing to the service address below. We will arrange as soon as possible for the defective equipment to be picked up from your address at no charge and will then supply you with a new or repaired replacement free of charge. Of course you can also return the defective equipment to the address below yourself (carriage forward).

Please prepare the equipment for the pick-up service (pack it in the original box or comparable box). You can make the arrangements for the pick-up yourself at the website below.

Please note that you or someone acting on your behalf must be available throughout the pick-up day. Don't forget to specify a pick-up address.

During non-office hours you can leave your phone number and we will call you back on the next work day.

After the guarantee period has elapsed you can still send a defective item to the address below for repair. When the guarantee period has ended, you must pay the costs of all repairs.

**Einhell UK**  
Unit 5,  
Morpeth Wharf, Twelve Quays,  
Birkenhead,  
Wirral,  
CH41 1LF





# WORKZONE®

## 14.4 V Lithium-Ion Cordless Drill/Screwdriver

Your details:

Name \_\_\_\_\_

Address \_\_\_\_\_

\_\_\_\_\_

 \_\_\_\_\_ E mail \_\_\_\_\_

Date of purchase\* \_\_\_\_\_

\*We recommend you keep the receipt with this warranty card

Location of purchase \_\_\_\_\_

Description of malfunction:

Return your completed warranty card to:

Einhell UK

Unit 5

Morpeth Wharf, Twelve Quays

Birkenhead

Wirral

CH 41 1LF

sales@einhell.co.uk

technical@einhell.co.uk

### AFTER SALES SUPPORT

 **0151 649 1500**  
(Charged at local rates)  [www.einhell.co.uk](http://www.einhell.co.uk)  
 **1890 946 6244**

WZAS 14,4 Li

XI/20/2011

# 3

YEAR WARRANTY





**Einhell Germany AG · Wiesenweg 22 · D-94405 Landau/Isar**



### Konformitätserklärung

- Ⓒ erklärt folgende Konformität gemäß EU-Richtlinie und Normen für Artikel
- Ⓒ explains the following conformity according to EU directives and norms for the following product
- Ⓒ déclare la conformité suivante selon la directive CE et les normes concernant l'article
- Ⓒ dichiara la seguente conformità secondo la direttiva UE e le norme per l'articolo
- Ⓒ verklaart de volgende overeenstemming conform EU richtlijn en normen voor het product
- Ⓒ declara la siguiente conformidad a tenor de la directiva y normas de la UE para el artículo
- Ⓒ declara a seguinte conformidade, de acordo com a directiva CE e normas para o artigo
- Ⓒ atterer følgende overensstemmelse i medfør af EU-direktiv samt standarder for artikel
- Ⓒ förklarar följande överensstämmelse enl. EU-direktiv och standarder för artikeln
- Ⓒ vakuuttaa, että tuote täyttää EU-direktiivin ja standardien vaatimukset
- Ⓒ töendab toote vastavust EL direktiivile ja standarditele
- Ⓒ vydává následující prohlášení o shodě podle směrnice EU a norem pro výrobek
- Ⓒ potvrjuje sledeću skladnost s smernico EU in standardi za izdelke
- Ⓒ vydáva nasledujúce prehlásenie o zhode podľa smernice EU a noriem pre výrobok
- Ⓒ a cikkhez az EU-irányvonal és Normák szerint a következő konformitást jelenti ki
- Ⓒ deklaruje zgodność wymienionego ponizej artykułu z następującymi normami na podstawie dyrektywy WE.
- Ⓒ декларира съответното съответствие съгласно Директива на ЕС и норми за артикул
- Ⓒ paskaidro šādu atbilstību ES direktīvai un standartiem
- Ⓒ apibūdina šį atitikimą EU reikalavimams ir prekės normoms
- Ⓒ declară următoarea conformitate conform directivei UE și normelor pentru articolul
- Ⓒ δηλώνει την ακόλουθη συμμόρφωση σύμφωνα με την Οδηγία ΕΚ και τα πρότυπα για το προϊόν
- Ⓒ potvrđuje sljedeću usklađenost prema smjernicama EU i normama za artikl
- Ⓒ potvrđuje sljedeću usklađenost prema smjernicama EU i normama za artikl
- Ⓒ potvrđuje sledeću usklađenost prema smernicama EZ i normama za artikla
- Ⓒ следующим удостоверяется, что следующие продукты соответствуют директивам и нормам ЕС
- Ⓒ проголошує про зазначену нижче відповідність виробу директивам та стандартам ЄС на виріб
- Ⓒ ja izjauva slednata soobraznost soglasno EU-direktivata i normite za artikli
- Ⓒ Ürünü ile ilgili AB direktifleri ve normları gereğince aşağıda açıklanan uygunluğu belirtir
- Ⓒ erklærer følgende samsvar i henhold til EU-direktiv og standarder for artikkel
- Ⓒ Lýsir uppfyllingu EU-reglna og annarra staða vöru

### Cordless Drill WZAS 14,4 Li / Charger LG WZAS 14,4 Li

- |  |  |
|--|--|
| <input type="checkbox"/> 87/404/EC_2009/105/EC                   | <input checked="" type="checkbox"/> 2006/42/EC (WZAS 14,4 Li)  |
| <input type="checkbox"/> 2005/32/EC_2009/125/EC                  | <input type="checkbox"/> Annex IV<br>Notified Body:<br>Notified Body No.:<br>Reg. No.:   |
| <input checked="" type="checkbox"/> 2006/95/EC (LG WZAS 14,4 Li) |  |
| <input type="checkbox"/> 2006/28/EC                              | <input type="checkbox"/> 2000/14/EC_2005/88/EC   |
| <input checked="" type="checkbox"/> 2004/108/EC                  | <input type="checkbox"/> Annex V   |
| <input type="checkbox"/> 2004/22/EC                              | <input type="checkbox"/> Annex VI<br>Noise: measured L <sub>WA</sub> = dB (A); guaranteed L <sub>WA</sub> = dB (A)<br>P = KW; L/G = cm<br>Notified Body: |
| <input type="checkbox"/> 1999/5/EC                               | <input type="checkbox"/> 2004/26/EC<br>Emission No.:   |
| <input type="checkbox"/> 97/23/EC                                |  |
| <input type="checkbox"/> 90/396/EC_2009/142/EC                   |  |
| <input type="checkbox"/> 89/686/EC_96/58/EC                      |  |

Standard references: EN 60745-1; EN 60745-2-1; EN 60745-2-2;  
EN 55014-1; EN 55014-2; EN 61000-3-2; EN 61000-3-3, EN 60335-1; EN 60335-2-29

Landau/Isar, den 14.07.2011

Weichselgartner/General Manager

Unger/Product-Management

First CE: 09  
Art. No.: 45.133.18 I.-No.: 11011  
Subject to change without notice

Archive-File/Record: NAPR004156  
Documents registrar: Fiedel Georg  
Wiesenweg 22, D-94405 Landau/Isar





EH 08/2011 (01)

