



MITRE SAW STAND



INSTRUCTION MANUAL

MODEL NUMBER TT-SH 240

AFTER SALES SUPPORT

TEL: 1300 922 271

EMAIL: service.australia@einhell.com

 N26704

MITRE SAW STAND

What your 3 year warranty means

Great care has gone into the manufacture of this product and it should therefore provide you with years of good service when used properly. In the event of product failure within its intended use over the course of the first 3 year after the date of purchase, we will remedy the problem as quickly as possible once it has been brought to our attention. In the unlikely event of such an occurrence, or if you require any information about the product, please contact us via our after sales support services, details of which can be found in this manual and on the product itself.

Welcome Section

Congratulations on choosing to buy a TAURUS TITANIUM® product.

All products brought to you by TAURUS TITANIUM® are manufactured to the highest standards of performance and safety, and, as part of our philosophy of customer service and satisfaction, are backed by our comprehensive 3 Year Warranty.

We hope you will enjoy using your purchase for many years to come.

Table of Contents

1. General Safety Rules	05
2. Assembling the saw stand	05
3. Attaching the device to the saw stand	05
4. Adjusting the supports	05
5. Maintenance	05
6. Ordering Spare Parts	05

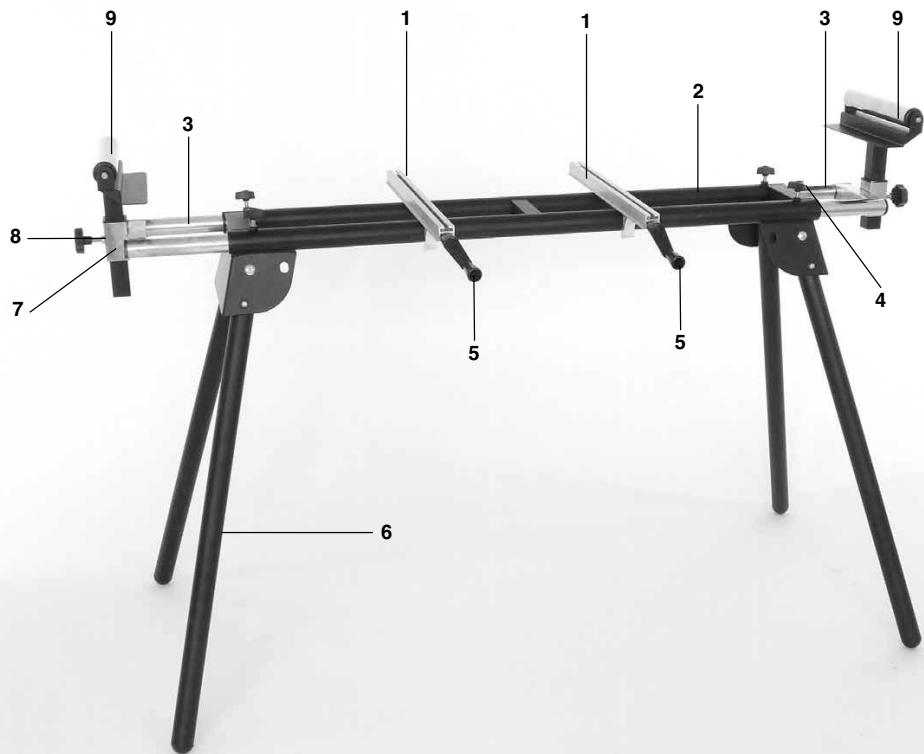
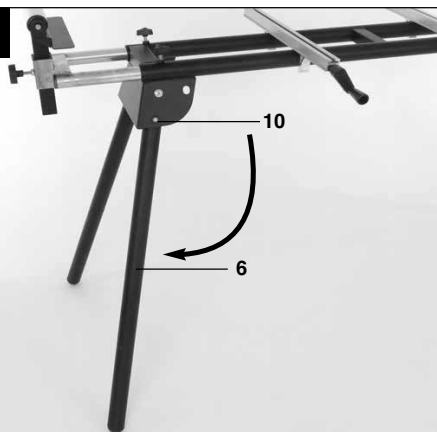
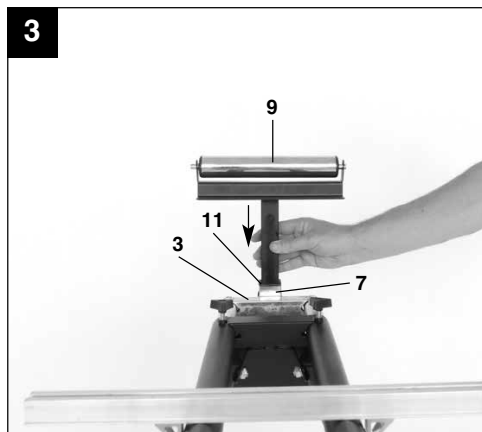

1**2****3****AFTER SALES SUPPORT**

1300 922 271



service.australia@einhell.com

3**MODEL NUMBER: TT-SH 240, 10/13**

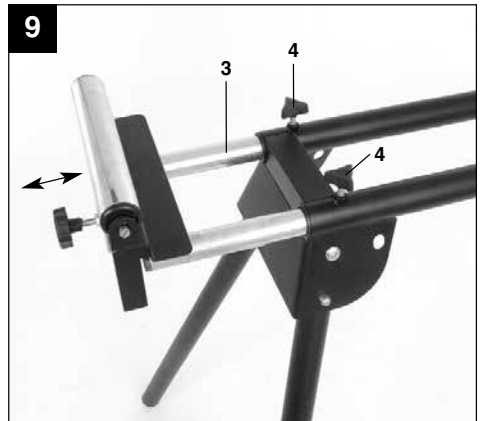
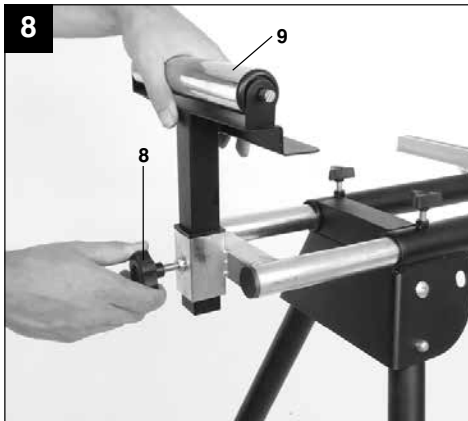
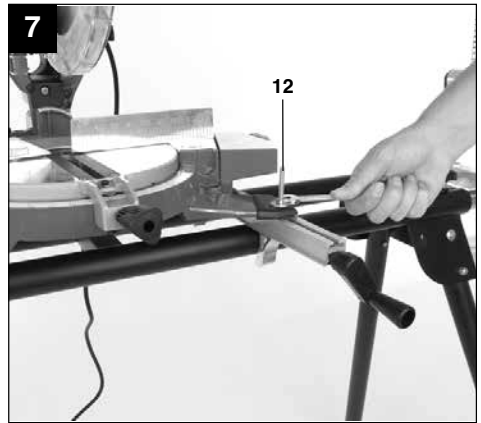
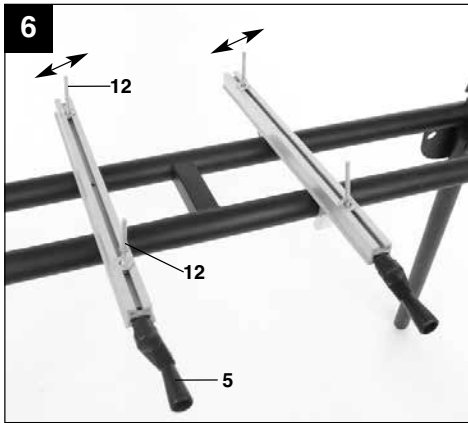
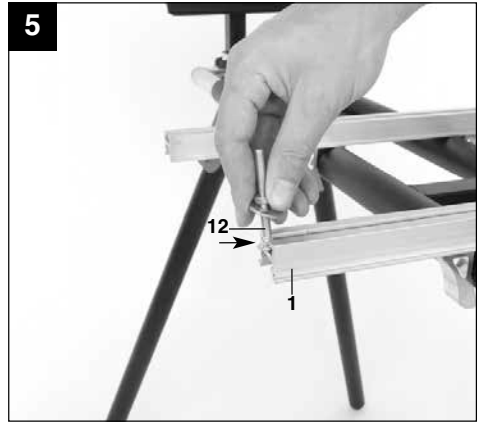
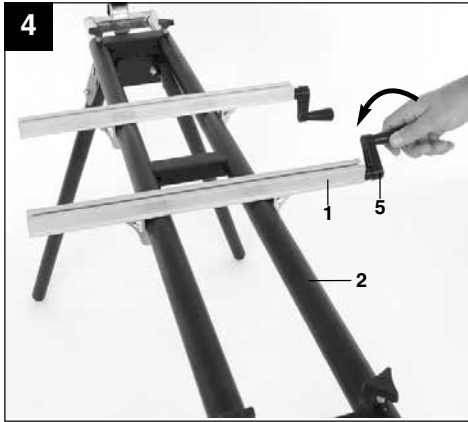

1. GENERAL SAFETY RULES

Attention! To avoid injury, follow this general safety advice:

This stand is designed for fixing mitre saws/sliding mitre saws and supporting longer workpieces. The stand must be used on an even and tidy ground.

When using this mitre saw stand, always fix the saw well with all 4 screws.

Do not overload the saw stand.

Follow the general safety principles for woodworking tools.

Follow the instruction manual and safety advice of the mitre saw that you use with this saw stand

2. Assembling the saw stand

(Fig. 1-4)

- Place the item on a support with its underside facing upwards. Push the button (10) and turn the feet (6) to the automatic fixing position. The button will lock with a noise.
- Turn the stand over and insert the supporting rollers (9) on the left and right into the mounts (7) on the side extension arms (3). In doing so, make sure the plastic guides (11) are positioned in the mounts (7).
- Place both adjustable fixing bars (1) on the two tubes (2) of the stand and secure with the aid of the crank (5).

3. Attaching the device to the saw stand (Fig. 5-7)

- To attach the saw, insert the 4 fixing screws (12) into the adjustable fixing bars (1).
- Slacken both fixing bars (1) by cranking towards the left, adjust the saw to the distance of the mounting holes and then re-secure the fixing bars by cranking towards the right.
- Align the fixing screws (12) in such a way that they correspond to the mounting holes of the saw (see Figure 6).
- Place the saw on the saw stand in such a way that the screws fit through the mounting holes.
- Secure the saw to the saw stand with the aid of the hexagonal nuts and washers provided (Fig. 7).

4. Adjusting the supports (Fig. 8-9)

- The supporting rollers for the workpiece must be adjusted to the support height of the saw. To

do this, slacken the knurled screw (8), adjust the supporting roller (9) to the desired height and resecure with the knurled screw (8).

- The extension arms (3) for the supporting rollers (9) can also be adjusted in length in order for them to match the workpiece optimally. To do this, slacken the thumb screws (4), pull out the extension arm (3) to the desired length (approximately 45 cm each) and re-secure with the thumb screws (4).

5. Maintenance

- In order to ensure good mobility of the components, dirt must be removed regularly and all moving parts (rollers, extension arms) must be lubricated at regular intervals. Cleaning is best carried out with compressed air or a rag.
- Never use caustic agents to clean plastic parts.

6. Ordering Spare Parts

Contact our After Sales Support on 1300 922 271

and quote the following data when ordering spare parts:

- Model/type of the equipment
- Article number of the equipment
- ID number of the equipment



AFTER SALES SUPPORT



1300 922 271



service.australia@einhell.com

AFTER SALES SUPPORT



1300 922 271



service.australia@einhell.com

TAURUS TITANIUM® is a registered trademark of ALDI Stores.

ALDI Guarantee

Specially made for ALDI Stores to our stringent quality specifications. If you are not entirely satisfied with this product, please return it to your nearest ALDI store, within 60 days from the date of purchase, for a full refund or replacement, or take advantage of our after sales support by calling the Supplier's Customer Service Hotline.

ALDI STORES
1 SARGENTS ROAD
MINCHINBURY NSW 2770
AUSTRALIA
www.aldi.com.au

10/2013

Art.Nr: 43.106.12_11013

AFTER SALES SUPPORT



1300 922 271



service.australia@einhell.com