



# Einhell

**BLUE**

## BG-DP 3730 Dirt water pump

**Art.-No. 41.704.70**

Powerful and robust dirt water pump to empty garden ponds, flooded basements and construction sites. It takes foreign particles up to Ø 30 mm in size. The pump is equipped with a float switch for automatic ON/OFF – operation for a varying water level. High quality standard at materials and constructional design, e. g. a stainless high-grade steel drive shaft warrants a maintenance-free operation and durable application.

### Features

- Handle (1)
- Float switch (2)
- Universal connection for 25mm (1") and 32mm (1 ¼") male thread hose connection as well as G1 (ca. 33.3 mm) male thread
- 90 °angel bracket with G1½ (ca. 47.8 mm) x G1½ (ca. 47.8 mm) male thread (3)
- Cable reel (4)
- High quality floating ring seal (5)

### Technical Data

- Mains: 230 V ~ 50 Hz
- Power: 370 W
- Delivery capacity max.: 9,000 l/h
- Delivery height max.: 5 m
- Immersion depth: 5 m
- Water temperature: 35 °C
- Hose connection: G 1½ (ca. 47.8 mm) female thread
- Foreign particle size up to: Ø 30 mm
- Mains cable: 10 m H05RN-F
- ON function: approx. 50 cm
- OFF function: approx. 5 cm
- Exhaust height: approx. 40 mm
- Product weight: 4.3 kg
- Gross weight: 4.8 kg
- Packing dimensions: 220 x 180 x 400 mm
- Bar code: 4006825556186
- Sales unit: 4 pcs



### Performance data:

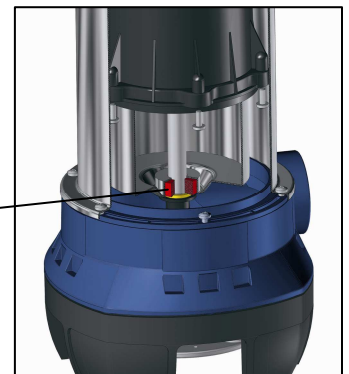
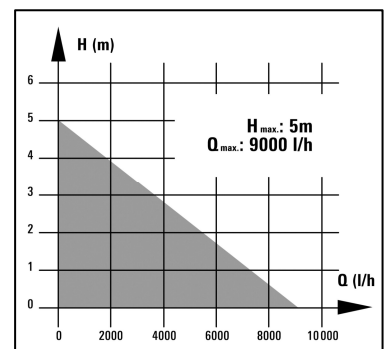

**As special accessory available:**

**PVC-drainage hose 10 m/1"**  
Einhell Grey

Art.-No.: 41.737.14

Bar code: 4006825549249



Abbildungen können nicht im Serien-Lieferumfang enthaltenes Zubehör darstellen / Illustrations can contain accessories, which are not included in standard extent of delivery. Abbildungen ähnlich, produktionsbedingte Abweichung vorbehalten / Illustration similar (in design), production-wise modifications reserved.

File: V:\Einhell-AG\TP-BK2013\TLT-Sek01-Sek-allgemein\Azubi\PA04-I-No-Wechsel-Anpassung-08-2013\Originale Englisch-Vorgaenger-Version\4170470\_11031.doc

Erstelldatum/create date: 02.03.2009 11:54:00Aktualisiert/up dated: 28.08.2013