

# POWER CRAFT

## User Guide & Warranty

1700 W SLIDING COMPOUND MITRE SAW WITH LASER

PSMS 2100



### After Sales Support

Now you have purchased a Power-Craft product you can rest assured in the knowledge that as well as your 3-year parts and labour warranty you have the added peace of mind of dedicated helplines and web support

### AFTER SALES SUPPORT

UK / N.IRELAND HELPLINE NO 0151 649 1500  
REP. IRELAND HELPLINE NO 1890 946 244

## Contents

- 06 Description
- 06 Items supplied
- 06 Proper use
- 07 Important notes
- 09 Technical data
- 09 Before putting the machine into operation
- 09 Assembly
- 11 Operating the laser
- 11 Maintenance
- 11 Ordering replacement parts



**Read the complete operating manual with due care and keep it in a safe place.  
If you give the machine to any other person, hand over this operating manual as well!**

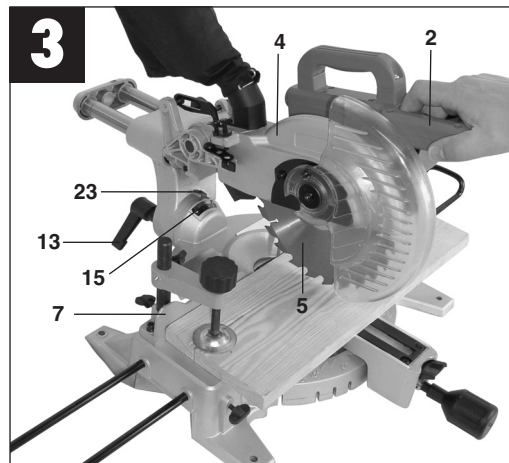
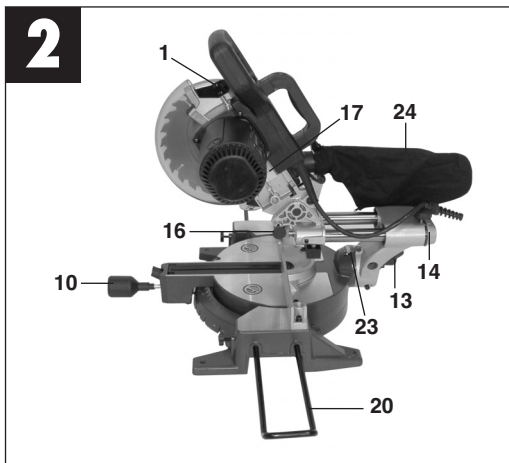
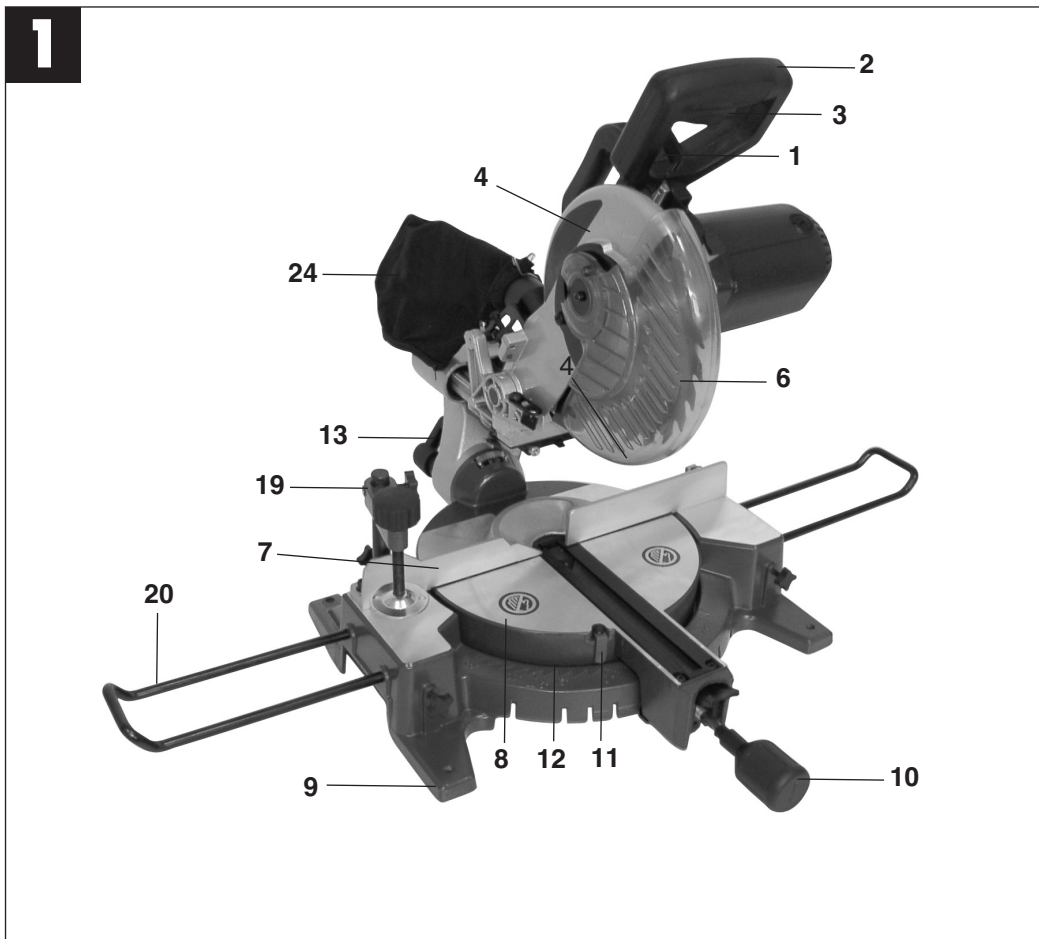

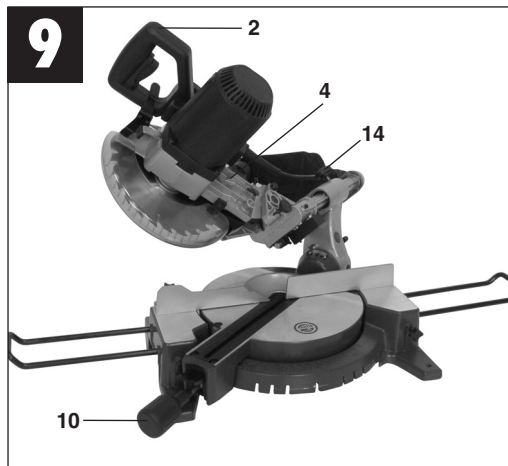
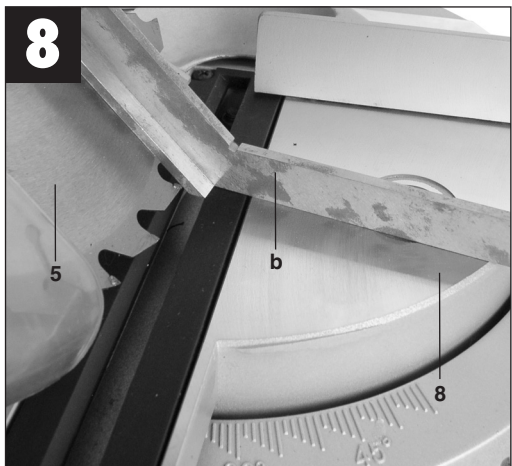
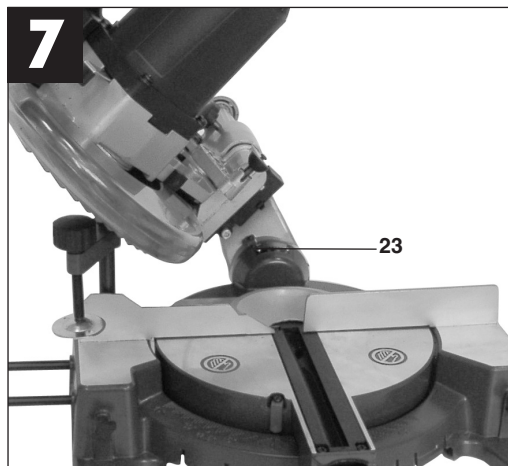
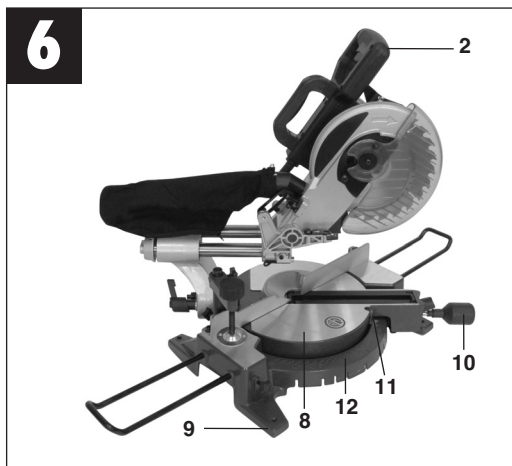
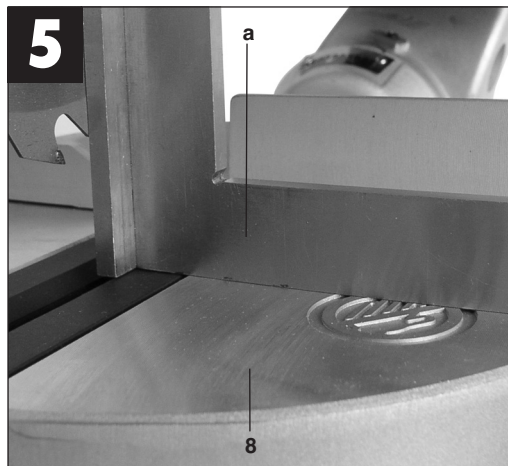
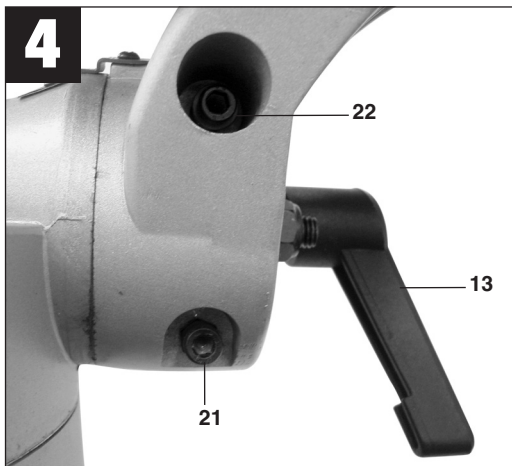

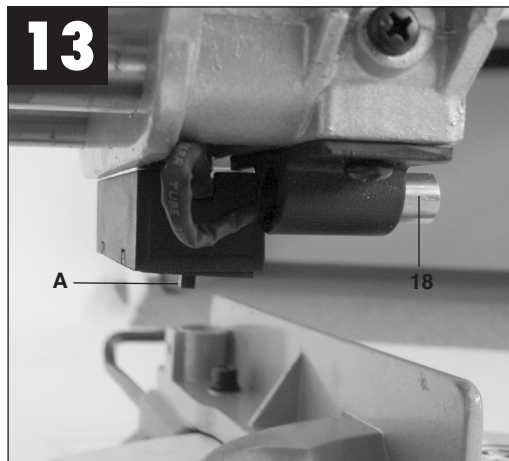
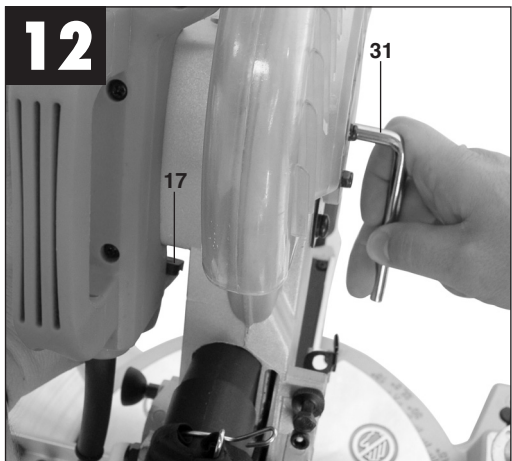
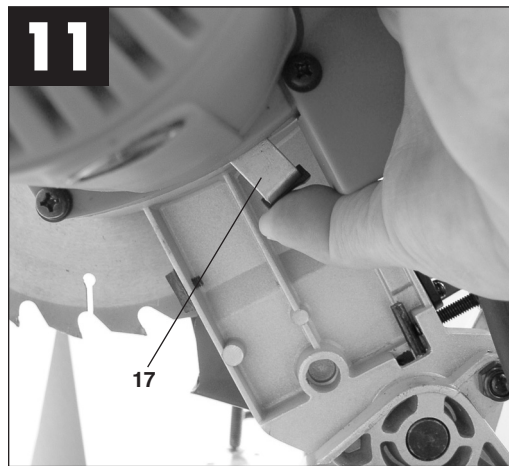
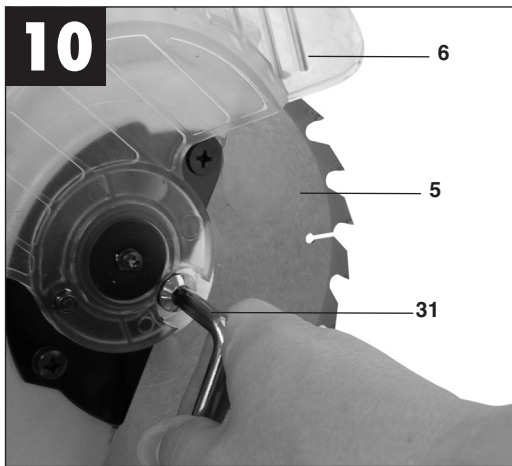



## 1. Description (Fig. 1/2)

1. Release lever
2. Handle
3. On/Off switch
4. Machine head
5. Saw blade
6. Saw blade guard, hinged
7. Stop rail
8. Turntable
9. Base plate, fixed
10. Locking handle
11. Pointer
12. Dial for turntable
13. Locking lever
14. Knurled screw
15. Scale
16. Retaining pin
17. Saw shaft lock
18. Laser

## 2. Items supplied

- Sliding Cross Cut Mitre Saw
- Clamping device (19)
- Workpiece support (20)
- Carbide-tipped saw blade (5)
- Dust bag (24)



**Caution: Laser radiation**  
**Do not look into the beam**  
**Laser class 2**

### **CAUTION: LASER RADIATION DO NOT LOOK INTO THE BEAM!**

**Laser specification according to**  
**EN 60950: 1992+A1+A2+A3+A4+A11**  
**EN 60825-1: 1994+A11:1996**  
**Laser class 2 1894S-8x17**  
**λ: 650 nm P: ≤ 5 mW**

Protect yourself and your environment from accidents by taking the appropriate precautionary measures.

- Do not look directly into the laser beam with the naked eye.
- Never look directly into the laser path.
- Never direct the laser beam at reflecting surfaces or persons or animals. Even a low output laser beam can inflict injury on the eye.

- **Caution:** It is vital to follow the work procedures described in these instructions. Using the tool in any other way may result in hazardous exposure to laser radiation.
- Never open the laser module.
- When the device is not going to be used for an extended period of time, the batteries should be removed.

## 3. Proper use

The sliding cross cut mitre saw is designed for cutting wood and plastic. This saw should not be used for cutting logs etc and MUST only be used for its prescribed purpose.

Any use other than that mentioned is considered to be a case of misuse. The user/operator and not the manufacturer shall be liable for any damage or injury resulting from such cases of misuse.

The machine is to be operated only with suitable saw blades. It is prohibited to use any type of cutting-off wheel.

To use the machine properly you must also observe the safety regulations, the assembly instructions and the operating instructions to be found in this manual.

All persons who use and service the machine have to be acquainted with this manual and must be informed about its potential hazards.

It is also imperative to observe the accident prevention regulations in force in your area.

The same applies for the general rules of occupational health and safety.

The manufacturer shall not be liable for any changes made to the machine nor for any damage resulting from such changes.

Even when the machine is used as prescribed it is still impossible to eliminate certain residual risk factors. The following hazards may arise in connection with the machine's construction and design:

- Contact with the saw blade in the uncovered saw zone.
- Reaching into the running saw blade (cut injuries).
- Kick-back of workpieces and parts of workpieces.
- Saw blade fracturing.
- Catapulting of faulty carbide tips from the saw blade.
- Damage to hearing if essential ear protection are not worn.
- Harmful emissions of wood dust when the machine is used in closed rooms.
- We also recommend that you wear safety glasses and gloves

## 4. Important notes

Please read this manual carefully and pay attention to the information provided. Use this manual to familiarise yourself with the machine, its correct use and safety regulations.

Please note that our equipment has not been designed for use in commercial, trade or industrial applications. Our warranty will be voided if the machine is used in commercial, trade or industrial businesses or for equivalent purposes.

### Safety regulations

- Always pull the plug out of the power socket before adjusting or servicing the machine.
- Give these safety regulations to all persons who work on the machine.
- Do not use this saw to cut logs.
- Caution! Hands and fingers may be injured on the rotating saw blade.
- Before you use the machine for the first time, check that the voltage marked on the rating plate is the same as your mains voltage.
- If you need to use an extension cable, make sure its conductor cross-section is big enough for the saw's power consumption. Minimum cross-section: 1.5 mm<sup>2</sup>.
- If you use a cable reel, the complete cable has to be pulled off the reel.
- Never carry the saw by its cable.
- Do not leave the saw in the rain and never use it in damp or wet conditions.
- Provide good lighting.
- Never saw near combustible liquids or gases.
- Wear suitable work clothes! Loose garments or jewellery may become caught up in the rotating saw blade.
- Keep children away from the machine when it is connected to the power supply.
- Check the power cable (9). Never use a faulty or damaged power cable.
- Keep your workplace clean of wood scrap and any unnecessary objects.
- Persons working on the machine should not be distracted.
- Note the direction of rotation of the motor and saw blade.
- After you have switched off the motor, never slow down the saw blade by applying pressure to its side.
- Fit only blades which are sharp and have no cracks or deformities.
- The machine is to be operated only with saw blades which conform with EN 847-1.
- Faulty saw blades have to be replaced immediately.
- Never use saw blades which do not comply with the data specified in this manual.
- Make sure that the arrow on the saw blade complies with the arrow marked on the machine.
- Make certain that the saw blade does not touch the rotary table in any setting. To do so, pull out the power plug and tilt the saw blade by hand into the 45° position and the 90° position. If necessary, re-adjust the saw head as described in Section (7.3/7.4).
- It is imperative to make sure that all the devices used to cover the saw blade are in good working order.
- Never wedge the hinged guard hood in open position.
- Never dismantle the machine's safety devices or put them out of operation.
- Damaged or faulty safety devices have to be replaced immediately.
- Never cut workpieces which are too small to hold securely in your hand.
- Do not place your hands in awkward positions where one or both may slip suddenly and touch the saw blade.
- When working with long workpieces, use an additional support (table, stand, etc.) to prevent the machine from tipping over.
- Always clamp round workpieces such as dowel rods etc. with suitable devices.
- There must be no nails or other foreign bodies in that part of the workpiece you want to cut.
- Always stand to the side of the saw blade when working with the saw.
- Never overload the machine.
- Always press the workpiece firmly against the table and the stop rail to prevent it from wobbling or twisting.
- Make sure that off-cuts can be removed from the side of the saw blade. If not, they may catch on the saw blade crown and be catapulted into the surrounding area.
- Never saw several workpieces simultaneously.
- Never remove loose splinters, chips or jammed pieces of wood when the saw blade is running.
- To rectify faults or remove jammed pieces of wood, always switch off the machine first. - Pull out the power plug!
- Conversions, adjustments, measurements and cleaning jobs are to be performed only when the motor is switched off. Pull out the power plug!

- Before you switch on the machine, check that all wrenches and adjustment tools have been removed.
- When you leave your workplace, switch off the motor and pull out the power plug.
- Electric installation work, repairs and maintenance are to be carried out only by specialists.
- All guards and safety devices have to be refitted immediately after completion of any repairs or maintenance.
- It is imperative to observe the manufacturer's safety, operating and maintenance instructions as well as the dimensions quoted in the technical data.
- It is imperative to observe the accident prevention regulations in force in your area as well as all other generally recognized rules of safety.
- Note the information published by your professional associations. (VBG7)
- Switch on the dust extraction system each time you use the machine.
- The machine may be used in closed rooms only in conjunction with a suitable vacuum extraction system.
- The saw must be connected to a 230 V socket outlet with a minimum 10 A fuse.
- Never use light-duty machines for heavy-duty work.
- Never use the cable for any purpose other than that for which it is intended!
- Adopt a firm standing position and keep your balance at all times.
- Check the tool for signs of damage!
- Before you carry on using the tool it is imperative to check that its safety devices and any slightly damaged parts are working properly and in the way intended.
- Check that the moving parts work properly and do not jam. Check if any of the parts are damaged. All parts must be fitted correctly and satisfy all conditions for the tool to work properly.
- Unless otherwise stated in these instructions, damaged safety devices and parts must be repaired or replaced by experts in an approved specialist workshop.
- Have damaged switches replaced by a customer service workshop.
- This tool complies with the pertinent safety regulations. Repairs are to be carried out only by qualified electricians using original replacement parts. The user may suffer an accident if this condition is not observed.
- Be careful when making vertical cuts.

- Take special care when making double mitre cuts.
- Do not overload the tool!
- Recommended Personal Protective Equipment
- Wear safety goggles.
- Use a breathing mask on dusty jobs.
- Wear ear protection.
- Wear gloves.
- Check the tool's power cable / extension cable for damage.



**Wear goggles**



**Wear ear protection**



**Wear a breathing mask**



**Wear gloves**

### Noise emission values

- The saw's noise is measured in accordance with DIN EN ISO 3744; 11/95, E Din EN 31201; 6/93, ISO 7960 Annex A; 2/95. The machine may exceed 85 dB(A) at the workplace. In this case, noise protection measures need to be introduced for the user (ear-protection).

	Idle speed
Sound pressure level $L_{pA}$	86 dB(A)
Sound power level $L_{WA}$	99 dB(A)

„The quoted values are emission values and not necessarily reliable workplace values. Although there is a correlation between emission and immission levels it is impossible to draw any certain conclusions as to the need for additional precautions. Factors with a potential influence on the actual immission level at the workplace include the duration of impact, the type of room, and other sources of noise etc., e.g. the number of machines and other neighbouring operations. Reliable workplace values may also vary from country to country. With this information the user should at least be able to make a better assessment of the dangers and risks involved.“



## 5. Technical data

Asynchronous motor	230 V~ 50 Hz
Output	1700 W
Operating mode	S1
Idle speed $n_0$	4800 min <sup>-1</sup>
Carbide-tipped saw blade	∅ 210 x ∅ 30 x 2,8 mm
Number of teeth	24
Tilting range	-45° / 0° / +45°
Mitre cuts	0° to 45° to the left
Sawing width at 90°	205 x 65 mm
Sawing width at 45°	145 x 65 mm
Sawing width at 2 x 45° (double mitre cuts)	145 x 40 mm
Weight	13,3 kg
Laser class	2
Laser wave length	650 nm
Laser output	≤ 5 mW
Laser power supply	2 x 1,5 V (AAA)

## 6. Before putting the machine into operation

- The machine must be firmly mounted in working position, e.g. on a workbench, the base frame supplied with the machine, or similar.
- All the covers and safety devices have to be properly fitted before the machine is switched on.
- It must be possible for the saw blade to run freely.
- When working with wood that has been processed before, watch out for foreign bodies such as nails or screws etc.
- Before you actuate the On/Off switch, make sure that the saw blade is correctly fitted and that the machine's moving parts run smoothly.
- Before you connect the machine to the power supply, make sure the data on the rating plate is the same as that for your mains.

## 7. Assembly

### 7.1 Setting up the saw unit (Fig. 1/2)

- To adjust the turntable (8), loosen the locking handle (10) by approx. 2 turns, which frees the turntable (8).
- Turn the turntable (8) and scale pointer (11) to the desired angular setting on the dial (12) and lock into place with the locking handle (10).
- Lightly press the machine head (4) down while at the same time pulling the retaining pin (16) out from the motor mounting; this causes the saw to move down to the lower working position.
- Swing the machine head (4) up until the retaining hook (1) latches into place.
- The clamping device (19) and the workpiece support (20) can be fastened on both the right and left sides of the base plate (9).
- By loosening the tightening screw (13), the machine head (4) can be angled to the left up to 45°.

### 7.2 Making 90° crosscuts with turntable at 0° (Fig. 1/3)

For cutting widths up to 100 mm it is possible to fix the saw's drag function with the knurled screw (14) in rear position. If the cutting width exceeds 100 mm you must ensure that the knurled screw (14) is slackened and that the machine head (4) can be moved.

- Bring the machine head (4) to its upper position.
- Push the machine head (4) back by its handle (2) and affix in this position if necessary (depending on the cutting width).
- Place the piece of wood to be cut against the stop rail (7) and on the turntable (8).
- Secure the workpiece in position with the clamping device (19) on the base plate (9) to prevent the workpiece from moving during the cutting process.
- Turn the release lever (1) to the left to release the machine head (4).
- Push the ON/OFF switch (3) to start the motor. Using the handle (2), push downward all the way through the work-piece with uniform and light pressure.
- After the cutting process is finished, bring the machine head back to its upper (home) position and release the ON/OFF button (3).

**Caution!** The resetting springs in the machine automatically raise the machine head. Do not simply let go of the handle (2) after cutting, but allow the machine head to slowly lift up by applying slight counterpressure.

### 7.3 Precision adjustment of the stop for crosscut 90° (Fig. 4/5)

- Lower the machine head (4) and fasten in place with the safety pin (16).
- Loosen the tightening screw (13).
- Place the angular stop (a) between the blade (5) and the turntable (8).
- Loosen the counternut and adjust the adjustment screw (21) until the angle between the blade (5) and the turntable (8) equals 90°.
- Retighten the counternut to secure this setting.
- Finally, check the position of the angle indicator (23). If necessary, release the pointer with a crosstip screwdriver, move to the 0° position of the angle scale (15) and retighten the holding screw.

### 7.4 Making 90° crosscuts with turntable at 0° - 45° (Fig. 6)

With the PSMS 2100 you can make right and left angular cuts from 0° - 45° to the stop rail.

- Use the handle (2) to set the turntable (8) to the desired angle i.e. the scale pointer (11) on the turntable must coincide with the desired angular setting (12) on the stationary base plate (9).
- Re-tighten the locking handle (10) to lock the turntable (8) into place.
- Cut as described under section 7.2.

### 7.5 Mitre cuts 0°-45° and rotary table 0° (Fig. 4/7)

The PSMS 2100 can be used to make mitre cuts of 0°-45° relative to the machine bed on the left side.

- Lift the machine head (4) to its top position.
- Fix the rotary table (8) in 0° position.
- Undo the locking nut (13) and, holding the handle (2), tilt the machine head (4) to the left until the pointer (23) coincides with the required angle dimension (15).
- Re-tighten the locking nut (13) and make the cut as described in Section 7.2.

### 7.6 Precision adjustment of the stop for 45° mitre cuts (Fig. 2/4/8)

- Lower the machine head (4) and fix with the lock pin (16).
- Fix the rotary table (8) in 0° position.
- Undo the locking nut (13) and, holding the handle (2), tilt the machine head (4) to the left by 45°
- Place the 45° stop angle (b) between the saw blade (5) and the rotary table (8).
- Slacken the counter nut and adjust the setting screw (22) until the angle between the saw (5) and the rotary table (8) equals exactly 45°.
- Re-tighten the locking nut (13) and make the cut as described in Section 7.2.

### 7.7 Mitre cuts 0°-45° and rotary table 0°-45° (Fig. 4/9)

The PSMS 2100 can be used to make mitre cuts on the left at an angle of 0°-45° relative to the work top and 0°-45° relative to the stop rail.

- Lift the machine head (4) to its top position.
- Release the turntable (8) by loosening the locking grip (10).
- Adjust the rotary table (8) by its handle (2) to the required angle (see also Section 7.4).
- Re-tighten the locking handle (10) to fix the rotary table in position.
- Undo the clamping nut (13) and, holding the handle (2), tilt the machine head (4) to the left to the required angle dimension (see also Section 7.5).
- Re-tighten the locking nut (13) and make the cut as described in Section 7.2.

### 7.8 Dust extraction (Fig. 1)

The saw is equipped with a dust collection bag (24). The dust bag (24) can be emptied by opening the zip fastener at the bottom.

### 7.9 Replacing the saw blade (Fig. 11)

- Pull out the power plug.
- Swing up the machine head (4).
- Press the lever and swing up the saw blade guard to the point where the recess in the saw blade guard is above the flange bolt.
- Press the saw shaft lock (17) with one hand while holding the wrench (31) on the flange bolt with the other.
- Firmly press on the saw shaft lock (17) and slowly rotate the flange bolt in clockwise direction. The saw shaft lock engages after no more than one rotation.
- Now, using a little more force, slacken the flange bolt in clockwise direction.
- Turn the flange bolt until it is completely removed.
- Take the blade (5) off the inner flange and pull out downwards.
- Mount the new saw blade in reverse order and fasten.  
Important! The cutting bevel of the teeth, i.e. the direction of rotation of the saw blade, has to conform with the direction of the arrow marked on the housing.
- Clean the saw blade flanges thoroughly before mounting the saw blade.
- Reattach the movable blade guard (6) in reverse order.
- Before using the saw again, check that the safety devices are in good working order.
- Important: Every time that you change the saw

blade, check to see that it spins freely in the groove of the turntable in both perpendicular and 45° angle settings.

## 8. Operating the laser (Fig. 13/14)

### To switch on:

Move the ON/OFF switch (1) to the "I" position.

A laser line is projected onto the material you wish to process, providing an exact cutting line.

### To switch off:

Move the ON/OFF switch (A) to the "0" position.

### Replacing the battery:

To replace the battery, proceed as shown in Fig. 14. Observe plus and minus signs in accordance with the battery and appliance; replace a whole set of batteries at once; remove batteries from appliance if it will not be used for some time; never dispose of batteries in fire, never attempt to recharge batteries, keep away from children.

## 9. Maintenance

- Keep the machine's air vents unclogged and clean at all times.
- Remove dust and dirt regularly from the machine. Cleaning is best done with compressed air or a rag.
- Re-lubricate all moving parts in regular intervals.
- Never use caustic agents to clean plastic parts.

## 10. Ordering replacement parts

Please quote the following data when ordering replacement parts:

- Type of machine
- Article number of the machine
- Identification number of the machine
- Replacement part number of the part required

For our latest prices and information please go to [www.isc-gmbh.info](http://www.isc-gmbh.info)

- The product meets the requirements of EN 61000-3-11 and is subject to special connection conditions.
- The product does not meet the requirements of EN 61000-3-3, meaning that use of the product at any freely selectable connection point is not allowed.
- The product is exclusively intended for use at connection points which
  - a) do not exceed a maximum permissible supply impedance  $Z$ , or
  - b) which have a continuous current-carrying capacity of the mains of at least 100 A per phase.
- As the user, you are required to ensure, in consultation with your electric power company if necessary, that the connection point at which you wish to operate the product meets one of the two requirements, a) or b), named above.
- The electric power company may impose restrictions for the connection of the product.

### WARRANTY CERTIFICATE

The product described in these instructions comes with a 3 year manufactures warranty covering defects. This 3-year manufactures warranty period begins with the passing of risk or when the customer receives the product.

For warranty claims to be accepted, the product has to receive the correct maintenance and be put to the proper use as described in the operating instructions.

**Your statutory rights of warranty are naturally unaffected during these 3 years.**

This warranty applies in Germany, or in the respective country of the manufacturer's main regional sales partner, as a supplement to local regulations. Please note the details for contacting the customer service center responsible for your region or the service address listed below.

Technical changes subject to change



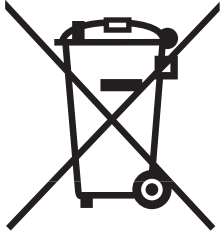

For EU countries only

Never place any electric tools in your household refuse.

To comply with European Directive 2002/96/EC concerning old electric and electronic equipment and its implementation in national laws, old electric tools have to be separated from other waste and disposed of in an environment-friendly fashion, e.g. by taking to a recycling depot.

Recycling alternative to the demand to return electrical devices:

As an alternative to returning the electrical device, the owner is obliged to cooperate in ensuring that the device is properly recycled if ownership is relinquished. This can also be done by handing over the used device to a returns center, which will dispose of it in accordance with national commercial and industrial waste management legislation. This does not apply to the accessories and auxiliary equipment without any electrical components which are included with the used device.

The reprinting or reproduction by any other means, in whole or in part, of documentation and papers accompanying products is permitted only with the express consent of ISC GmbH.



## Konformitätserklärung

Einhell AG · Wiesenweg 22 · D-94405 Landau/Isar

**D** erklärt folgende Konformität gemäß EU-Richtlinie und Normen für Artikel  
**GB** declares conformity with the EU Directive and standards marked below for the article  
**F** déclare la conformité suivante selon la directive CE et les normes concernant l'article  
**NL** verklaart de volgende conformiteit in overeenstemming met de EU-richtlijn en normen voor het artikel  
**E** declara la siguiente conformidad a tenor de la directiva y normas de la UE para el artículo  
**P** declara a seguinte conformidade de acordo com a directiva CE e normas para o artigo  
**S** förklarar följande överensstämmelse enl. EU-direktiv och standarder för artikeln  
**FIN** ilmoittaa seuraavaa Euroopan unionin direktiivien ja normien mukaista yhdenmukaisuutta tuotteelle  
**N** erklærer herved følgende samsvar med EU-direktiv og standarder for artikkel  
**HR** izjavljuje sljedeću uskladenost s odredbama i normama EU za artikl.  
**RO** declară următoarea conformitate cu linia directoare CE și normele valabile pentru articolul.  
**TR** ürün ile ilgili olarak AB Yönetmelikleri ve Normları gereğince aşağıdaki uygunluk açıklama masını sunar.  
**GR** δηλώνει την ακόλουθη συμφωνία σύμφωνα με την Οδηγία ΕΕ και τα πρότυπα για το προϊόν

**I** dichiara la seguente conformità secondo la direttiva UE e le norme per l'articolo  
**DK** attesterer følgende overensstemmelse i henhold til EU-direktiv og standarder for produkt  
**CZ** prohlašuje následující shodu podle směrnice EU a norem pro výrobek.  
**HU** a következő konformitást jelenti ki a termékerekre vonatkozó EU-irányvonalak és normák szerint  
**SK** pojednává nasledujúce skladnost po smernici EU in normah za artikel.  
**PL** deklaruje zgodność wymienionego ponizej artykułu z następującymi normami na podstawie dyrektywy WE.  
**SV** vydáva nasledujúce prehlásenie o zhode podľa smernice EÚ a noriem pre výrobok.  
**RU** декларирует следующее соответствие согласно директив и норм на ЕС за продукта.  
**UKR** заявляє про відповідність згідно з Директивою ЄС та стандартами, чинними для даного товару  
**EE** deklareerib vastavuse järgnevalele EL direktiivi dele ja normidele  
**LT** deklaruoja atitiktį pagal ES direktyvas ir normas  
**CS** izjavlja sledeći konformitet u skladu s odredbom EZ i normama za artikl  
**LV** Atbilstības sertifikāts apliecina zemāk minēto preču atbilstību ES direktīvām un standartiem  
**IS** Samræmisýfirlýsing staðfestir eftirfarandi samræmi samkvæmt reglum Evrópubandalagsins og stöðlum fyrir vörur

## Zug-, Kapp- und Gehrungssäge PSMS 2100

<input checked="" type="checkbox"/> 98/37/EG	<input type="checkbox"/> 87/404/EWG
<input checked="" type="checkbox"/> 73/23/EWG_93/68/EEC	<input type="checkbox"/> R&TTED 1999/5/EG
<input type="checkbox"/> 97/23/EG	<input type="checkbox"/> 2000/14/EG:
<input checked="" type="checkbox"/> 89/336/EWG_93/68/EEC	<input type="checkbox"/> 95/54/EG:
<input type="checkbox"/> 90/396/EWG	<input type="checkbox"/> 97/68/EG:
<input type="checkbox"/> 89/686/EWG	

**EN 61029-2-9; EN 55014-1; EN 55014-2; EN 61000-3-2;  
EN 61000-3-11; EN 60825-1; EN 60950; EN 61029-1**

Landau/Isar, den 11.01.2007

  
Weichselgartner  
General-Manager

  
Baumstark  
Product-Management

Art.-Nr.: 43.006.69 I.-Nr.: 01017  
Subject to change without notice

Archivierung: 4300660-09-4155050



**1700 W SLIDING COMPOUND MITRE SAW WITH LASER**  
PSMS 2100

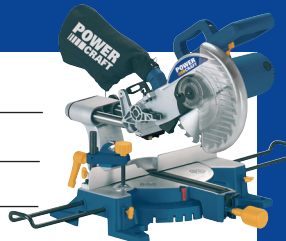

Name: \_\_\_\_\_

Address: \_\_\_\_\_  
\_\_\_\_\_

Contact Telephone No.: \_\_\_\_\_

Fault Description: \_\_\_\_\_  
\_\_\_\_\_  
\_\_\_\_\_

Please complete this section before sending in your warranty certificate

In order to deal with your enquiry please call our customer helpline on the number shown on this page.

Service:  
Einhell UK Ltd  
Unit 5 Morpeth Wharf  
Twelve Quays  
Birkenhead, Wirral  
**CH 41 1LF**

**UK / N.IRELAND HELPLINE NO: 0151 649 1500**  
**REP. IRELAND HELPLINE NO: 1890 946 244**