

# *challenge* **xtreme**

## **Operating Instructions Compressor**

**WARNING! PLEASE READ THESE INSTRUCTIONS BEFORE  
OPERATING THIS UNIT**

**KEEP THIS MANUAL FOR FUTURE REFERENCE**



**EH-Art.-No.: 40.205.06**

**I.-Nr.: 01028**

**CX 200/24 OF**

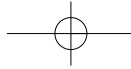

## Warning!

When using compressors, basic safety precautions should always be followed to reduce the risk of fire, electric shock and personal injury.

Read all these instructions before attempting to operate this product.

Keep these instructions with the compressor.

Save these instructions for future reference.

## Use Personal Protection Safety Equipment.

The compressor ejects high-pressure air. Always wear protective eye goggles and avoid contact with air outlets. Protect eyes with safety glasses or goggles – use safety glasses or goggles which conform to BSEN136 or CE equivalent that provide protection from the front and side.

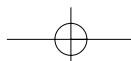
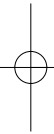
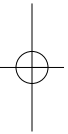

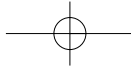

Wear goggles!



Note the instructions for use!



Wear ear defenders!



Beware of electrical voltage



Beware of hot parts

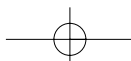
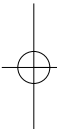
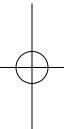

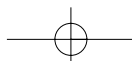
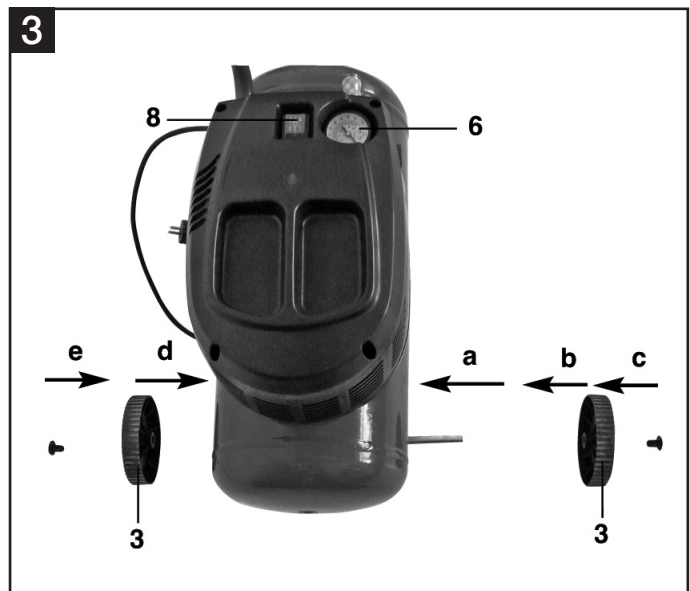
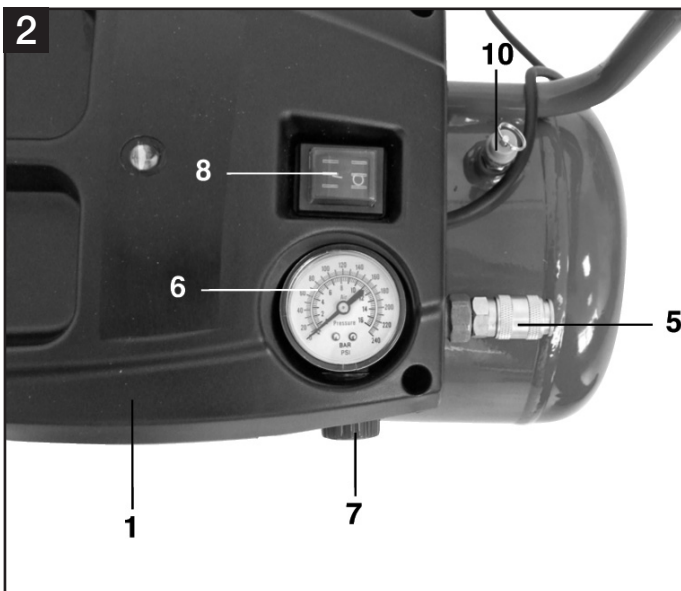
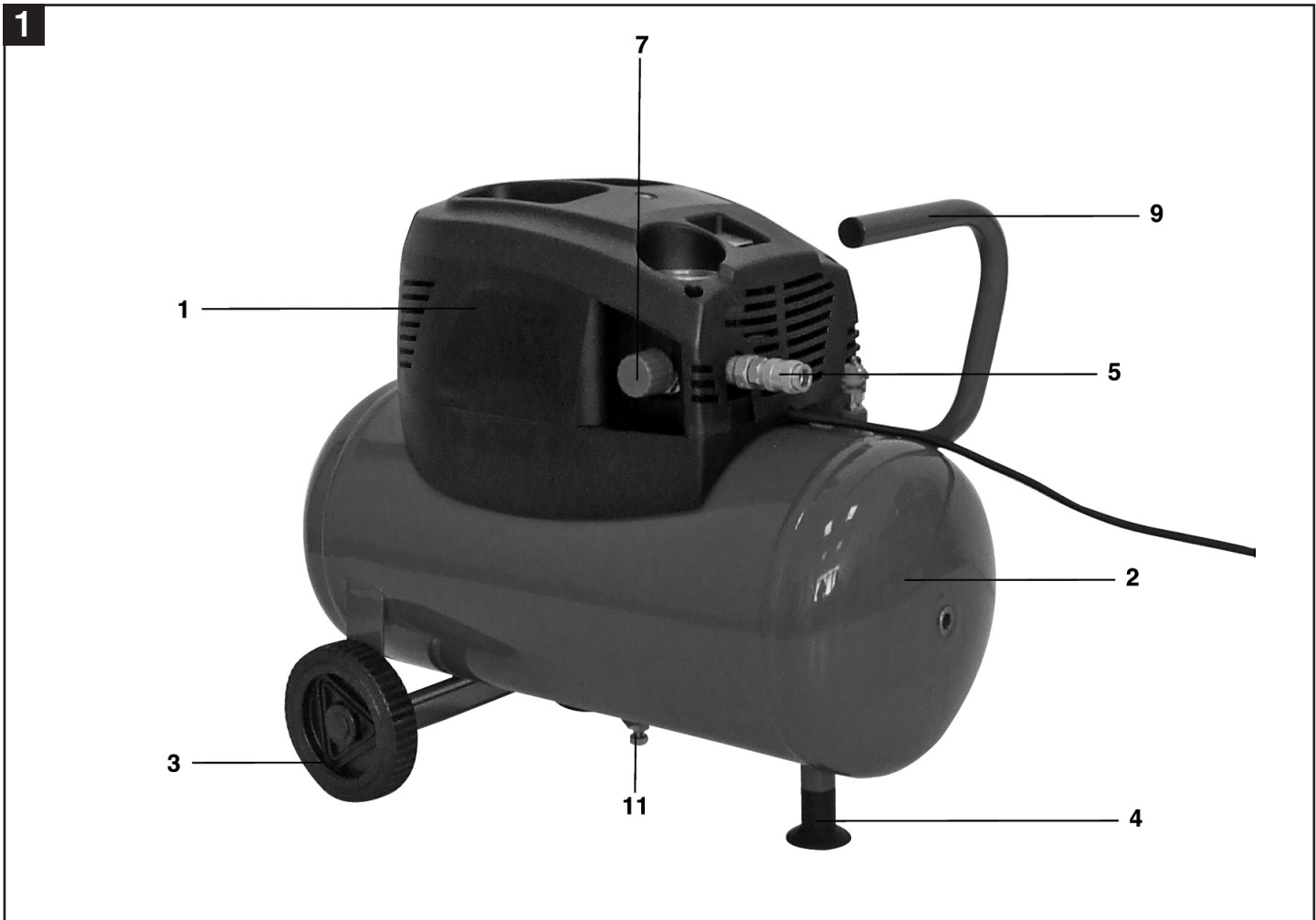
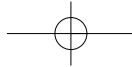

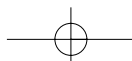
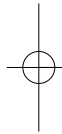
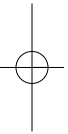
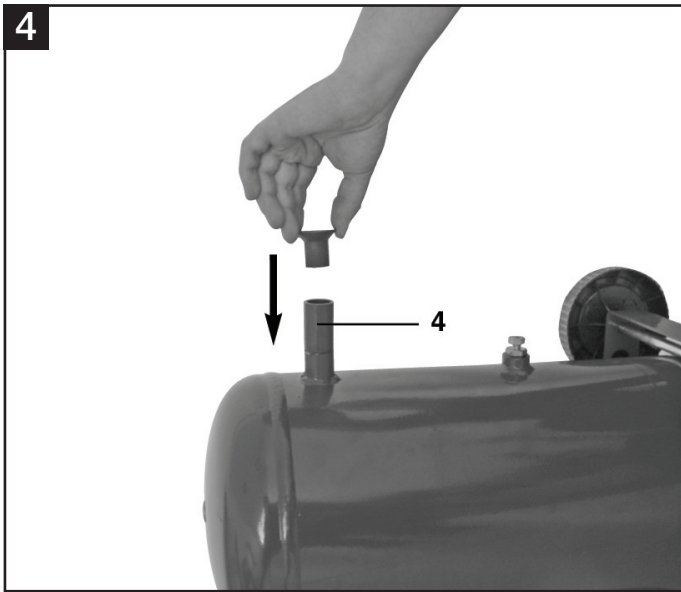
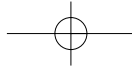

## Important!

When using equipment, a few safety precautions must be observed to avoid injuries and damage. Please read the complete operating manual with due care. Keep this manual in a safe place, so that the information is available at all times. If you give the equipment to any other person, give them these operating instructions as well. We accept no liability for damage or accidents which arise due to non-observance of these instructions and the safety information.

## 1. Safety instructions

### 1.1 General safety instructions

#### Important!

The following basic safety precautions have to be taken when using this compressor in order to guard against the risk of electric shock, injury and fire. Read and note these instructions before you use the compressor.

#### 1. Keep your work area tidy

- There is a higher risk of accident in an untidy work area.

#### 2. Make allowance for environmental conditions

- Never leave the compressor in the rain. Never use the compressor in damp or wet conditions. Provide good lighting. Never use the compressor near combustible liquids or gases.

#### 3. Protect yourself from electric shocks

- Avoid physical contact with earthed parts, e.g. pipes, radiators, cookers, refrigerators.

#### 4. Keep children away!

- Do not allow other persons to touch the compressor or its cable. Keep them out of your work area.

#### 5. Keep your compressor in a safe place

- When the compressor is not being used it should be kept in a dry, locked room out of the reach of the children.

#### 6. Do not overload your compressor

- It is better and safer to work within the quoted power range.

#### 7. Wear suitable work clothes

- Do not wear loose garments or jewellery. There is a risk of them catching on moving parts. Rubber gloves and non-slip shoes are recommended when working outdoors. Put on a hair net if you have long hair.

#### 8. Never use the cable for any purpose other than that intended

Never tow the compressor by its cable and never pull the power plug out of the socket by the cable. Protect the cable from heat, oil and sharp edges.

#### 9. Look after your compressor

- Keep your compressor clean so that it works well and reliably. Follow the maintenance instructions. Check the power plug and cable regularly and have them replaced by a specialist if you discover any damage. Check any extension cables regularly and replace if damaged.

#### 10. Pull out the power plug

- Whenever the compressor is not being used and before carrying out any maintenance work.

#### 11. Avoid accidental starts

- Make sure that the switch is turned to OFF before you connect the compressor to the power supply.

#### 12. Extension cables for outdoor use

- Use extension cables outdoors only if they are approved and marked accordingly.

#### 13. Concentrate at all times

- Watch your work. Be sensible. Do not use the compressor if your mind is not on your work.

#### 14. Examine your compressor for signs of damage

- Before you use the compressor again, carefully check its safety devices or any slightly damaged parts to make sure that they are working properly and as intended. Check moving parts to make sure that they are in good working order and are not jammed or damaged. All parts have to be properly fitted in order to be sure of meeting all the machine's requirements. Damaged safety devices and parts have to be repaired or replaced by a customer service workshop unless otherwise stated in this manual. Damaged switches have to be replaced by a customer service workshop. Do not use any tools with a switch that cannot be turned on and off.

#### 15. Important!

- For your own safety, use only such accessories and auxiliary equipment as are listed in this manual or which are recommended and specified by the manufacturer. There is a high risk of suffering a serious accident if you use tools or accessories which are not listed in this manual or in the catalogue of recommended tools and accessories.

#### 16. Have an electrician carry out repairs

- Repairs are to be carried out only by a qualified electrician. If not, the user may suffer serious accidents.

#### 17. Noise

Use ear muffs when you use the compressor.

#### 18. Replacing the power cable

To prevent injury, damaged power cables may only be replaced by the manufacturer or a qualified electrician.

### 1.2 Safety instructions for working with compressed air and blasting guns

- Compressors and lines reach high temperatures during operation. Avoid contact! Risk of burns!
- Gases or vapours drawn in by the compressor have to be kept free of constituents that may cause fire or explosions inside the compressor.
- When you disconnect the hose coupling, hold the coupling element in your hand to prevent injury from the whiplashing hose.
- Wear goggles when working with the blow-out gun. Injuries may easily result from foreign bodies and blasted parts.
- Never point the blow-out gun at other persons and never use it to clean clothes that are still being worn.

### 1.3. Safety information for paint spraying

- Never process paints or solvents with a flash point below 55°C.
- Never heat paints or solvents.
- It is imperative to use filtering equipment (face masks) when processing harmful liquids. Note also the information concerning safety precautions published by the manufacturers of these liquids.
- Smoking is prohibited during the spraying operation and in the work room. Paint vapours are highly flammable.
- Make sure there are no open fires or open lights in the work room. Sparking machines are not to be used.
- Do not keep or consume food and drink in the work room. Paint vapours are harmful.
- The details and designations of the Ordinance on Hazardous Substances, which are displayed on the outer packaging of the processed material, must be observed. Additional protective measures are to be undertaken if necessary, particularly the wearing of suitable clothing and masks.
- The work room has to be bigger than 30 m<sup>3</sup> and have sufficient ventilation for spraying and drying. Never spray into the wind. It is always imperative to observe the regulations of your local police authorities when spraying combustible or hazardous substances.
- Never process media such as white petroleum spirit, butyl alcohol and methylene chloride with the PVC pressure hose (reduced life span).

### 1.4 Operating pressure vessels

- An operator of a pressure vessel is required to keep the pressure vessel in good working order, to operate it properly, to supervise its use, to carry out essential maintenance and repair work immediately, and to introduce essential safety measures according to requirements.
- The supervisory authorities may order essential safeguards from case to case.
- A pressure vessel may not be operated if it has any defects which constitute a danger to employees or third parties.
- The pressure vessel must be regularly inspected for damage, e.g. rust. If you discover any damage, then please contact the customer service workshop.
- Keep these safety instructions in a safe place.

## 2. Layout

1. Housing cover
2. Pressure vessel
3. Wheel
4. Supporting foot
5. Quick-lock coupling (regulated compressed air)
6. Pressure gauge (for reading the preset tank pressure)
7. Pressure regulator
8. ON/OFF switch
9. Transportation handle
10. Safety valve
11. Drainage screw for condensation water

## 3. Scope of use

The compressor is designed for generating compressed air for tools operated by compressed air.

Please note that our equipment has not been designed for use in commercial, trade or industrial applications. Our warranty will be voided if the machine is used in commercial, trade or industrial businesses or for equivalent purposes. The machine is to be used only for its prescribed purpose. Any other use is deemed to be a case of misuse. The user / operator and not the manufacturer will be liable for any damage or injuries of any kind caused as a result of this.

## 4. Technical data

Power supply: 230 - 240V ~ 50Hz

Motor rating in kW/HP: 1.1/1,5

Operating mode S3 25% 10 min

Compressor speed in rpm: 17500

Operating pressure in bar: 8

Pressure vessel volume in litre: 24

Theoretical intake rate in l/min.: 176

Sound power level LWA in dB: 94.5

Sound pressure level LpA in dB: 74.5

Protection type: IP 20

Machine weight in kg: 15.7

Operating mode S3 - 25% - 10min: S3 = Intermittent mode without influencing the starting process. This means that during a period of 10 min the max. operating time is 25% (2.5 min).

## 5. Points to note when setting up the compressor

- Examine the machine for signs of transit damage. Report any damage immediately to the company which delivered the compressor.
- The compressor should be set up near the working consumer.
- Avoid long air lines and long supply lines (extensions).
- Make sure the intake air is dry and dust-free.
- Do not set up the compressor in damp or wet rooms.
- The compressor may only be used in suitable rooms (with good ventilation and an ambient temperature from +5°C to +40°C). There must be no dust, acids, vapors, explosive gases or inflammable gases in the room.
- The compressor is designed to be used in dry rooms. It is prohibited to use the compressor in areas where work is conducted with sprayed water.

## 6. Assembly and starting

### ⚠ Important!

You must fully assemble the appliance before using it for the first time.

#### 6.1 Fitting the wheels (3)

Fit the supplied wheels as shown in Fig. 3.

#### 6.2 Fitting the supporting foot (4)

Fit the supplied rubber stopper as shown in Fig. 4.

#### 6.3 Voltage

The compressor is equipped with a mains cable with shock-proof plug. This can be connected to any 230V ~ 50Hz shock-proof socket which is protected by a 13 A fuse. Before you use the machine, make sure that the mains voltage complies with the specifications on the rating plate. Long supply cables, extensions, cable reels etc. cause a drop in voltage and can impede motor start-up. In the case of low temperatures below +5°C, motor start-up is jeopardized as a result of stiffness.

#### 6.4 On/Off switch (8)

To switch on the equipment set the On/Off switch (8) to position 1.

Move the On/Off switch (8) to position 0 to switch off the equipment.

#### 6.5 Adjusting the pressure: (Fig. 1)

- You can adjust the pressure on the pressure gauge (6) using the pressure regulator (7).
- The set pressure can be taken from the quicklock coupling (5).

#### 6.6 Setting the pressure switch

The pressure switch is set at the factory.

Switch-on pressure 6 bar

Switch-off pressure 8 bar

## 7. Cleaning and maintenance

### ⚠ Important!

Pull the power plug before doing any cleaning and maintenance work on the appliance.

### ⚠ Important!

Wait until the compressor has completely cooled down. Risk of burns!

### ⚠ Important!

Always depressurize the tank before carrying out any cleaning and maintenance work.

#### 7.1 Cleaning

- Keep the safety devices free of dirt and dust as far as possible. Wipe the equipment with a clean cloth or blow it with compressed air at low pressure.
- We recommend that you clean the appliance immediately after you use it.
- Clean the appliance regularly with a damp cloth and some soft soap. Do not use cleaning agents or solvents; these may be aggressive to the plastic parts in the appliance. Ensure that no water can get into the interior of the appliance.
- You must disconnect the hose and any spraying tools from the compressor before cleaning. Do not clean the compressor with water, solvents or the like.

#### 7.2 Condensation water

The condensation water must be drained off each day by opening the drain valve (11) (on the floor of the pressure vessel).

### ⚠ Important!

The condensation water from the pressure vessel will contain residual oil. Dispose of the condensation water in an environmentally compatible manner at the appropriate collection point.

#### 7.3 Safety valve (10)

The safety valve has been set for the highest permitted pressure of the pressure vessel. It is prohibited to adjust the safety valve or remove its seal. Actuate the safety valve from time to time to ensure that it works when required. Pull the ring with sufficient force until you can hear the compressed air being released. Then release the ring again.

#### 7.4 Storage

### ⚠ Important!

Pull the mains plug out of the socket and ventilate the appliance and all connected pneumatic tools. Switch off the compressor and make sure that it is secured in such a way that it cannot be started up again by any unauthorized person.

### ⚠ Important!

Store the compressor only in a dry location which is not accessible to unauthorized persons. Always store upright, never tilted!



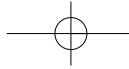

## 8. Ordering replacement parts

Please quote the following data when ordering replacement parts:

- Type of machine
- Article number of the machine
- Identification number of the machine
- Replacement part number of the part required

For our latest prices and information please go to [www.isc-gmbh.info](http://www.isc-gmbh.info)

## 9. Disposal and recycling

The unit is supplied in packaging to prevent its being damaged in transit. This packaging is raw material and can therefore be reused or can be returned to the raw material system.

The unit and its accessories are made of various types of material, such as metal and plastic. Defective components must be disposed of as special waste. Ask your dealer or your local council.

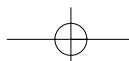
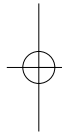
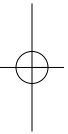

## 10. Possible causes of failure

Problem	Cause	Solution
<b>The compressor does not start</b>	1. No supply voltage.	1. Check the supply voltage, the power plug and the socket-outlet.
	2. Insufficient supply voltage.	2. Make sure that the extension cable is not too long. Use an extension cable with large enough wires.
	3. Outside temperature is too low.	3. Never operate with an outside temperature of below +5°C.
	4. Motor is overheated.	4. Allow the motor to cool down. If necessary, remedy the cause of the overheating.
	5. The compressor motor may be faulty.	5. Please contact the Argos customer helpline.
<b>The compressor starts but there is no pressure</b>	1. Leak in the non-return valve (13).	1. Replace the non-return valve.
	2. The seals are damaged.	2. Check the seals and have any damaged seals replaced by a service center.
	3. The drainage screw for condensation water (14) leaks.	3. Tighten the screw by hand. Check the seal on the screw and replace if necessary.
	4. The tank contains traces of water from condensation.	4. Unscrew the drainage valve to remove traces of condensation.
<b>The compressor starts, pressure is shown on the pressure gauge, but the tools do not start</b>	1. Loose hose connections	1. Check the compressed air hose and tools and replace if necessary
	2. Leak in a quick-lock coupling.	2. Check the quick-lock coupling and replace if necessary.
	3. Insufficient pressure set on the pressure regulator.	3. Open the pressure regulator further.
<b>The compressor is noisy with metallic clangs when in operation.</b>	Compressor head gasket or valve faulty.	Please contact the Argos Helpline.
<b>The compressor does not stop when the tank pressure reaches its maximum working pressure.</b>	Pressure switch defective or needs adjusting.	Please contact the Argos Helpline.
<b>The compressor does not start and makes a humming noise</b>	Capacitor may be faulty.	Please contact the customer helpline.
<b>The compressor has stopped and does not start</b>	Overload cut-out operated because of motor overheating.	Allow the motor to cool down. If necessary remedy the cause of the overheating.

Contact Number for Argos Power Tool Helpline:

**0870 725 2949**



## Declaration of Conformity

ISC-GmbH · Eschenstraße 6 · D-94405 Landau/Isar

- D** erklårt folgende Konformität gemäß EU-Richtlinie und Normen für Artikel  
**GB** declares conformity with the EU Directive and standards marked below for the article  
**F** déclare la conformité suivante selon la directive CE et les normes concernant l'article  
**NL** verklaart de volgende conformiteit in overeenstemming met de EU-richtlijn en normen voor het artikel  
**E** declara la siguiente conformidad a tenor de la directiva y normas de la UE para el artículo  
**P** declara a seguinte conformidade de acordo com a directiva CE e normas para o artigo  
**S** förklarar följande överensstämmelse enl. EU-direktiv och standarder för artikeln  
**FIN** ilmoittaa seuraavaa Euroopan unionin direktiivien ja normien mukaista yhdenmukaisuutta tuotteelle  
**N** erklærer herved følgende samsvar med EU-direktiv og standarder for artikkel  
**RUS** заявляет о соответствии товара следующим директивам и нормам ЕС  
**HR** izjavljuje sljedeću uskladenost s odredbama i normama EU za artikl.  
**RO** declară următoarea conformitate cu linia directoare CE și normele valabile pentru articolul.  
**TR** ürün ile ilgili olarak AB Yönetmelikleri ve Normları gereğince aşağıdaki uygunluk açıklama masını sunar.  
**GR** δηλώνει την ακόλουθη συμφωνία σύμφωνα με την Οδηγία ΕΕ και τα πρότυπα για το προϊόν

- I** dichiara la seguente conformità secondo la direttiva UE e le norme per l'articolo  
**DK** attesterer følgende overensstemmelse i henhold til EU-direktiv og standarder for produkt  
**CZ** prohlašuje následující shodu podle směrnice EU a norem pro výrobek.  
**H** a következő konformitást jelenti ki a termékere vonatkozó EU-irányvonalak és normák szerint  
**SL** pojasnjuje sledečo skladnost po smernici EU in normah za artikel.  
**PL** deklaruje zgodność wymienionego poniżej artykułu z następującymi normami na podstawie dyrektywy WE.  
**SK** vydáva nasledujúce prehlásenie o zhode podľa smernice EU a noriem pre výrobok.  
**BG** декларира следното съответствие съгласно директивите и нормите на ЕС за продукта.  
**UKR** заявляє про відповідність згідно з Директивою ЄС та стандартами, чинними для даного товару  
**EE** deklareerib vastavuse järgnevalele EL direktiivi dele ja normidele  
**LT** deklaruoja atitikti pagal ES direktyvas ir normas  
**RS** izjavljuje sledeći konformitet u skladu s odredbom EZ i normama za artikl  
**LV** Atbilstības sertifikāts apliecina zemāk minēto preču atbilstību ES direktīvām un standartiem  
**IS** Samræmisýfirlýsing staðfestir eftirfarandi samræmi samkvæmt reglum Evrópubandalagsins og stöðlum fyrir vörur

## Challenge Xtreme CX 200/240F Compressor

<input type="checkbox"/>	98/37/EC	<input checked="" type="checkbox"/>	87/404/EEC
<input checked="" type="checkbox"/>	2006/95/EC	<input type="checkbox"/>	R&TTED 1999/5/EC
<input type="checkbox"/>	97/23/EC	<input checked="" type="checkbox"/>	2000/14/EG_2005/88/EC: $L_{WM} = 95,7 \text{ dB}$ ; $L_{WA} = 97 \text{ dB}$ $P = 1,1 \text{ kW}$
<input checked="" type="checkbox"/>	2004/108/EC	<input type="checkbox"/>	95/54/EC:
<input type="checkbox"/>	90/396/EEC	<input type="checkbox"/>	97/68/EC:
<input type="checkbox"/>	89/686/EEC		

**EN 1012-1; EN 60204-1; EN 60335-1; EN 55014-1;  
EN 55014-2; EN 61000-3-2; EN 61000-3-3;**

Landau/Isar, den 14.04.2008

  
Brunhölzl  
Leiter Produkt-Management

  
Karg  
Produkt-Management

Art.-Nr.: 40.205.06 I.-Nr.: 01028  
Subject to change without notice

Archivierung: 4020505-40-4176375-08

