

# QUALCAST



# 750 Watt Electric Tiller

## Original Operating Instructions



**FOLDING HANDLE FOR  
EASY TRANSPORT**



**2 POINT SAFETY  
SWITCH**



**4 TILLER BLADES**



**ERGONOMIC LONG  
HANDLE**



**30CM WORKING WIDTH**



## AFTER SALES SUPPORT

UK / IRELAND HELPLINE NO 0151 6491500  
REP. IRELAND HELPLINE NO 1890 946244  
WEB SUPPORT [www.einhell.co.uk](http://www.einhell.co.uk)

MODEL NUMBER: ER30  
HOMEBASE ARTICLE NUMBER: 323439



# Contents

- 03. Safety Guide
- 06. Product Diagrams
- 09. Assembly
- 11. Technical Data
- 12. Declaration of Conformity
- 14. Product Guarantee

## **Packaging**

The unit is supplied in packaging to prevent its being damaged in transit. This packaging is raw material and can therefore be reused or can be returned to the raw material system.

## Safety Notes



**Warning! Read these instructions carefully, be familiar with the controls and the proper use of the tiller. Please keep the instruction safe for later use.**

Explanation of symbols on the tiller



Note the instructions for use!



Important. Rotating tool.



Caution! Danger from catapulted parts; keep a safe distance.



Wear ear defenders!



Wear safety goggles!



Wear safety gloves



If the cable is damaged or cut, pull out the power plug from the mains immediately.



Never use the equipment in damp locations.

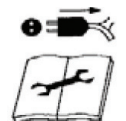

Pull the power plug before carrying out maintenance, cleaning and repair work.

## 1. Safety Instructions

**Warning! When using electric tools, basic safety precautions should always be followed to reduce the risk of fire, electric shock and personal injury, including the following. Read all these instructions before attempting to operate this product and keep these instructions in a safe place.**

### 1. Keep work area clean

Cluttered areas and benches invite injuries.

### 2. Consider work area environment

Don't expose power tools to rain. Don't use power tools in damp or wet locations. Keep work area well lit. Don't use power tools in presence of flammable liquids or gases.

### 3. Guard against electric shock

Prevent body contact with grounded surfaces (e.g. pipes, radiators, refrigerators).

### 4. Keep children away

Do not let visitors contact tool or extension cord. All visitors should be kept away from work area.

### 5. Store idle tools

When not in use, tools should be stored in dry, or locked-up place, out of the reach of children.

### 6. Don't force tool

It will do the job better and safer at the rate for which it was intended.

### 7. Use right tool

Don't force small tools or attachments to do the job of heavy duty tool. Don't use tools for purposes not intended: for example, don't use circular saw for cutting tree limbs or logs.

### 8. Dress properly

Do not wear loose clothing or jewellery. They can be caught in moving parts. Rubber gloves and non-slip footwear are recommended when working outdoors. Wear protective hair covering to contain long hair.

### **9. Use safety glasses**

Also use face or dust mask if cutting operation is dusty.

### **10. Don't abuse cord**

Never carry tool by cord or yank it to disconnect it from the socket. Keep cord from heat, oil and sharp edges.

### **11. Don't overreach**

Keep proper footing and balance at all times.

### **12. Maintain tools with care**

Keep tools sharp and clean for better and safer performance. Follow instructions for lubricating and changing accessories. Inspect tool cords periodically and, if damaged, have repaired by a service workshop. Inspect extension cords periodically and replace if damaged. Keep handles dry, clean and free from oil and grease.

### **13. Disconnect tools**

When not in use, before servicing, and when changing accessories such as blades, bits and cutters.

### **14. Remove adjusting keys and wrenches**

Form the habit of checking to see that keys and adjusting wrenches are removed from tool before turning it on.

### **15. Avoid unintentional starting**

Don't carry plugged-in tool with your finger on switch. Be sure switch is off when plugging in.

### **16. Outdoor use extension cords**

When tool is used outdoors, use only extension cords intended for use outdoors and so marked.

### **17. Stay alert**

Watch what you are doing. Use common sense. Do not operate tool when you are tired.

### **18. Check damaged parts**

Before further use of the tool, a guard or other part that is damaged should be carefully checked to determine that it will operate properly and perform its intended function. Check for alignment of moving parts, binding of moving parts, breakage of parts, mounting, and any other conditions that may affect its operation. A guard or other part that is damaged should be properly repaired or replaced in a service workshop unless otherwise indicated elsewhere in this instruction manual. Have defective switches replaced by a service workshop. Do not use the tool if the switch does not turn it on and off.

### **19. Warning**

The use of any other accessory or attachment other than those recommended in this operating instruction may present a risk of personal injury.

### **20. Have your tool repaired by an expert**

This electric appliance is in accordance with the relevant safety rules, the repair of electric appliances may be carried out only by experts otherwise it may cause considerable danger for the user.

## **Additional safety instructions**

Read the operating instructions with due care. Familiarize yourself with the operator controls and proper operation of the machine

Never allow children or other persons who are not familiar with the operating instructions to use the machine.

Never work in the direct vicinity of persons - especially children - or animals.

Always keep in mind that the machine operator or user is responsible for accidents involving other persons and/or damage to their property.

## Preliminary measures

Always wear sturdy, non-slip footwear and long trousers when working. Never operate the machine barefoot or in sandals.

Check the ground on which the machine will be used and remove all objects that could be caught up and violently flung out by it.

Before using the machine, always visually examine the tools for excessive wear or damage. To prevent any imbalance, replace worn out or damaged parts and mounting bolts as a set only.

The power cables used are not to be of a lighter duty class than light rubber-insulated H05RN-F in accordance with DIN 57282/VDE 0282 and they must have a cross section of at least 1.5 mm<sup>2</sup>. The connection must be splash-proof. The power cable must be fed through the stress-relief clips and be plugged into the switch/plug block. Before use, check the cable for damage and signs of aging. Never use the machine with worn or damaged cables. If the cable is damaged while working, pull the power plug immediately and only then inspect the damage. Do not touch the power cable until the plug has been pulled.

Plugs and sockets used on extension cables must be made from rubber, soft PVC or other thermal material of equal rigidity or coated with such material.

Make sure that all nuts, bolts and screws are tightened securely and that the machine is in safe working condition.

## Handling

Work only in daylight or in good light.

Always maintain good footing on inclines.

Only operate the machine at a walking pace. Work perpendicular to the slope, never up or down it.

Be particularly careful when you change direction on a slope.

Do not work on overly steep inclines.

Be particularly careful when you turn the machine around or pull it toward yourself.

Switch on the motor carefully as described in the instructions from the manufacturer and ensure that you keep your feet at a safe distance from the tool.

Never move your hands or feet toward or under any rotating parts.

Never lift or carry a machine whilst the motor is running; in addition the power plug should be pulled.

Switch off the motor whenever you leave the machine unattended.

If the machine begins to experience unusual vibrations, immediately switch it off and check it.

Ensure that you avoid paths that could restrict the free movement of the extension cable.

## Maintenance and storage

Always make sure that all nuts, bolts and screws are tightened securely so that the machine is in safe working condition.

Allow the motor to cool before you put the machine in an enclosed area.

For your own safety, replace worn or damaged parts without delay.

Switch the machine off and pull the power plug before carrying out any adjustment or cleaning work on it, and before checking to see if the mains connection is entwined or damaged.

Switch off the motor and pull the power plug; before you dislodge any blockages or clogs. before you clean the machine, inspect it or carry out work on the machine. after you have traveled over an obstacle. if you have struck a foreign object. Do not lose these safety regulations.

A

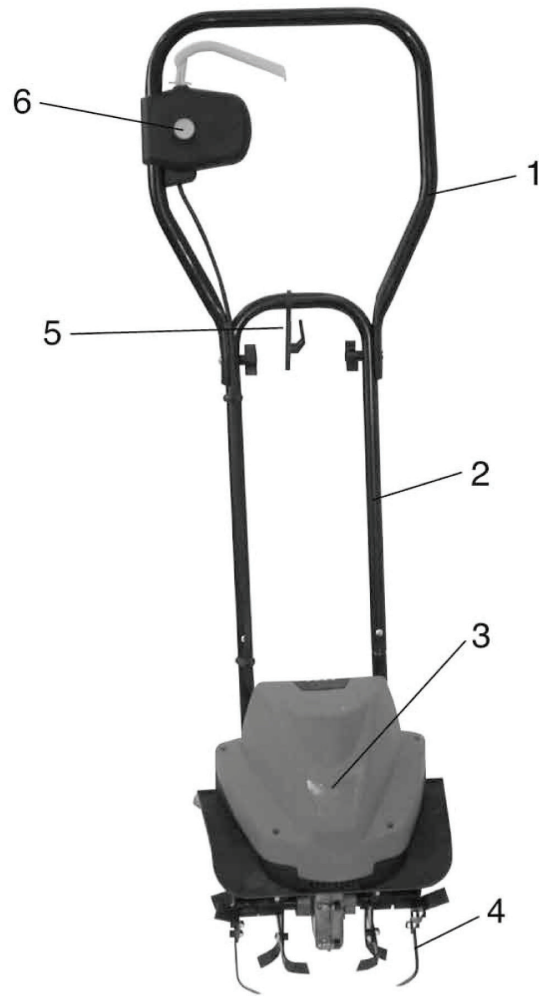

B

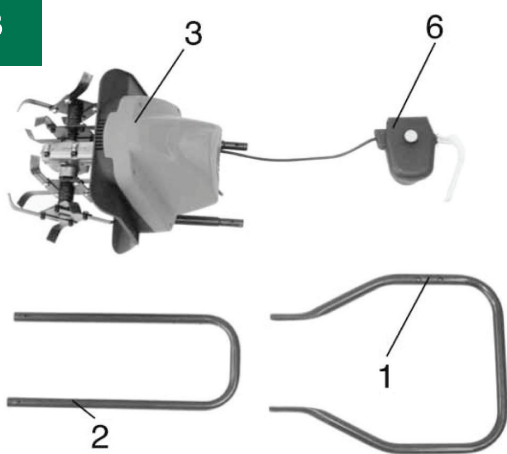

C

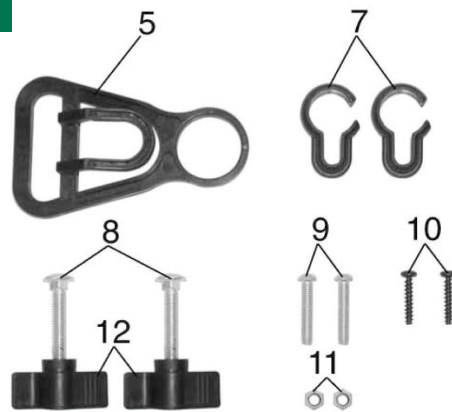

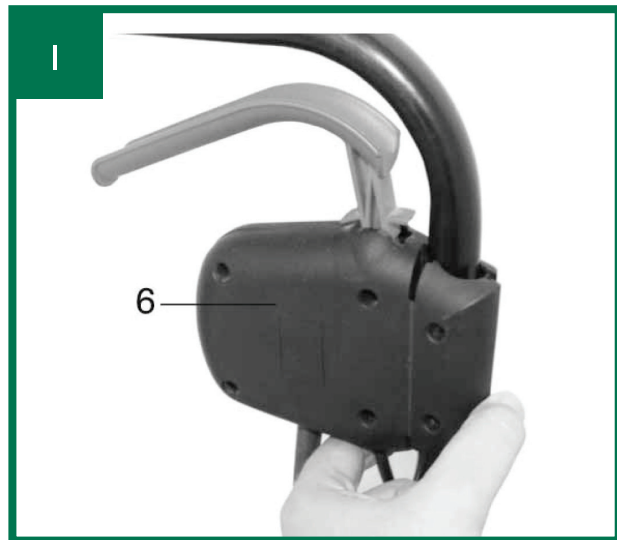
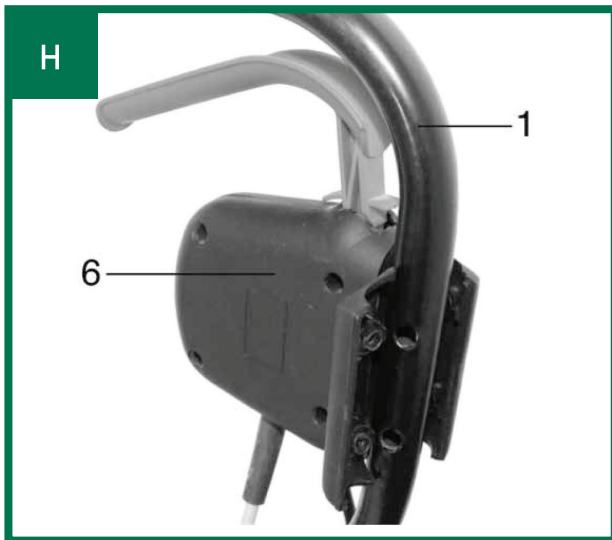
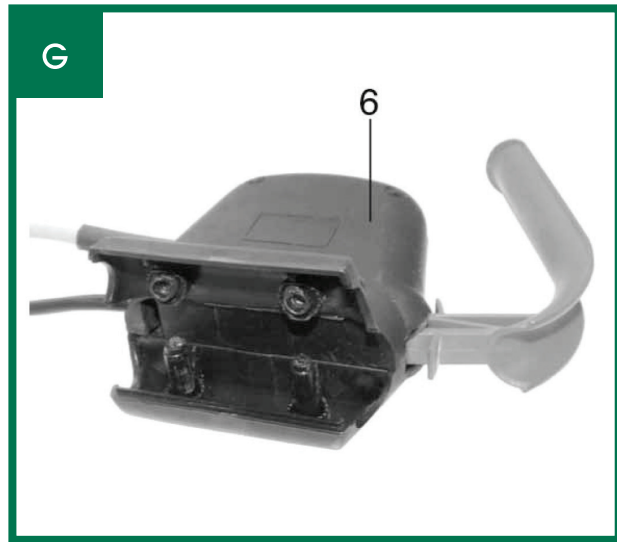
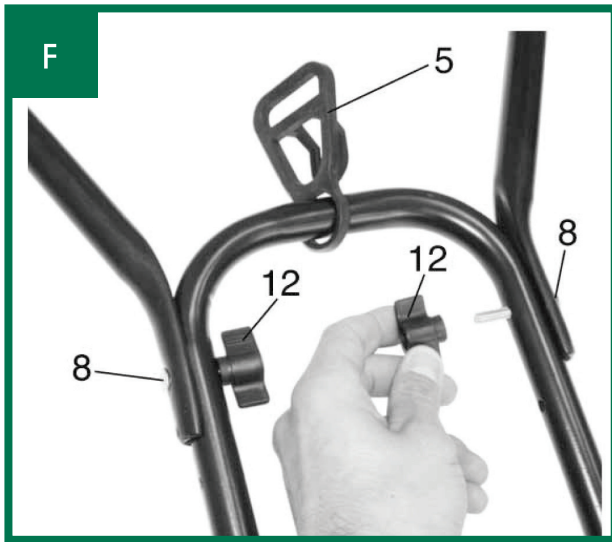
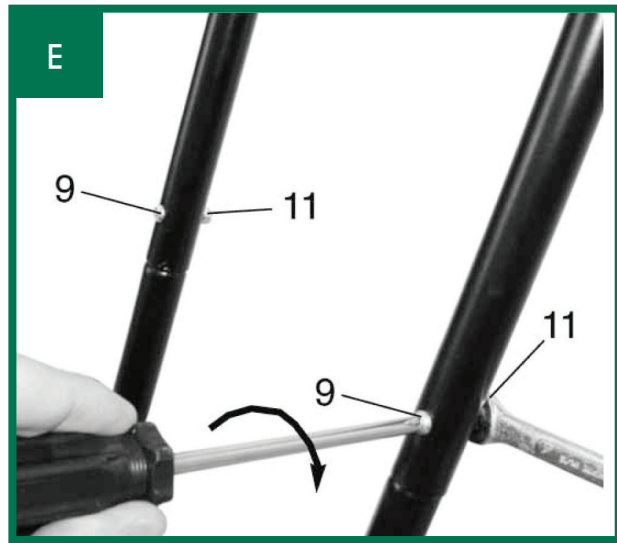
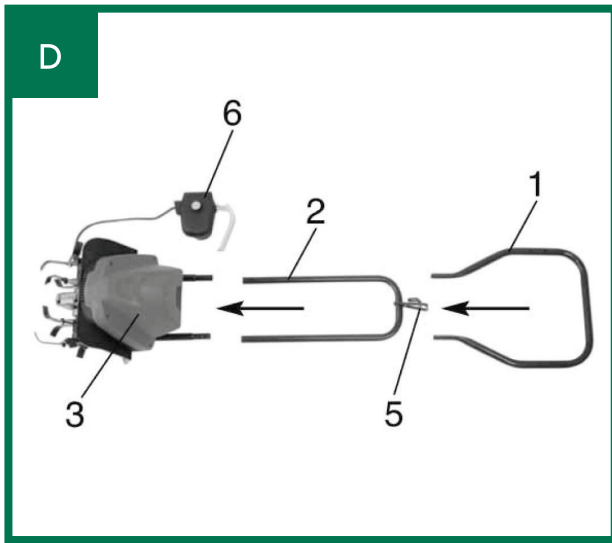

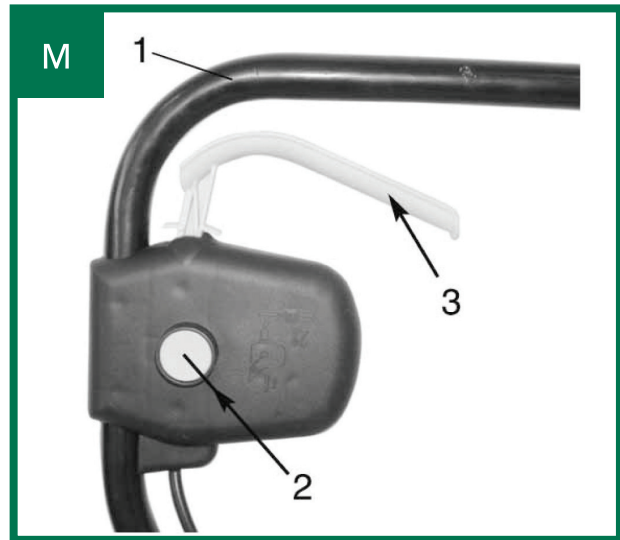
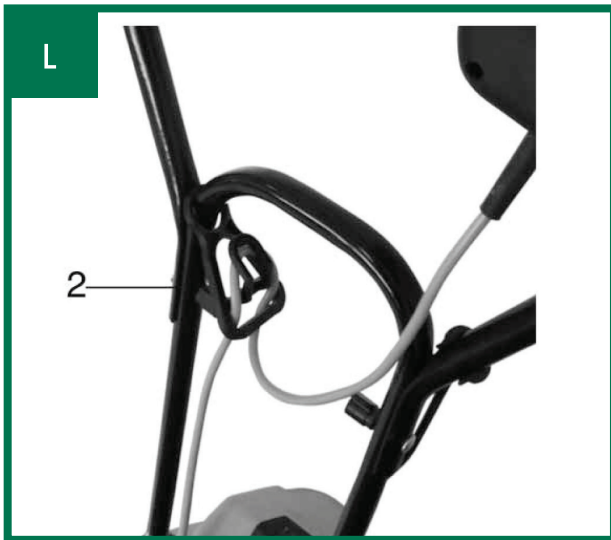
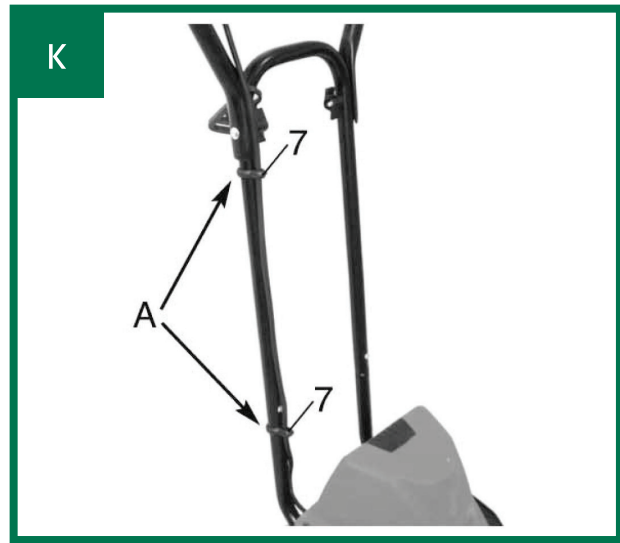
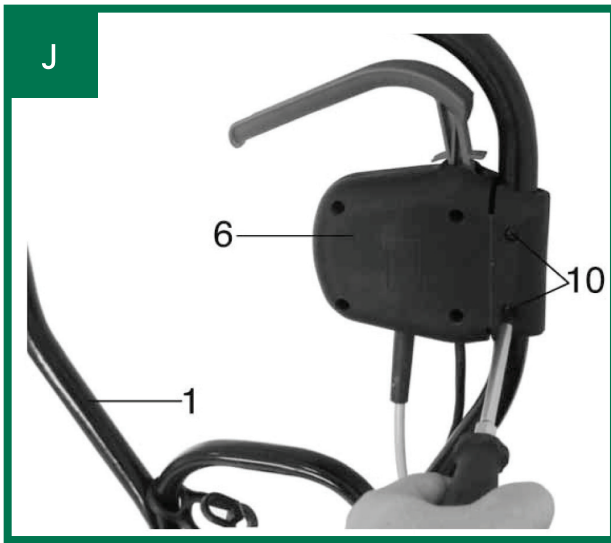



## 2. Layout and items supplied

### See Fig. A-C

1. Top push bar
2. Bottom push bar
3. Motor unit
4. Tiller blades
5. Cable strain-relief clamp
6. Two-hand safety switch
7. Cable securing clips
8. 2x screw for installing the top push bar
9. 2x screw for installing the bottom push bar
10. 2x screw for installing 2-hand safety switch
11. 2x nut M6
12. 2x wing nut

## 3. Proper use

The machine is designed for digging soil (for example garden beds). Be sure to observe the restrictions in the safety instructions.

## 4. Proper operation

### Power supply

The machine can be connected to any 13A socket outlet (with 230 Volt alternating current). However, the socket outlet must have an earthing contact protected by a 16 A circuit breaker. Also, a 30mA max. residual current device (RCD) circuit breaker must be fitted as protection to the socket outlet circuit!

### Power cable for the device

Please only use power cables that are not damaged. The total length of the power cable should not exceed 50 meters; going beyond this distance will reduce the power output of the electric motor. The power cable must have a crosssection of 3 x 1.5 mm<sup>2</sup>. The insulating sheath of such machines is frequently damaged. Some of the causes for this are:

- Cracking due to old age of the insulation
  - Kinking caused by improper fastening or guidance of the power cable
- Even though power cables with damaged insulation sheaths

pose a lethal hazard, some people still use them. Do not make this mistake! Cables, plugs and socket couplers must meet the following requirements listed below. Power cables used to connect machines must have a rubber insulation sheath.

The power cables must, at the very minimum, be of type HO5RN-F and 3-stranded. The cable type must be printed somewhere on the power cable. Only purchase power cables that are marked! Plugs and socket couplers for the power cables must be made from rubber and splash-proof. There is a limit to how long power cables can be. Longer power cables require larger conductor cross-sections. Power cables and connecting lines must be regularly checked for damage. Ensure that the lines are deenergized before checking them. Completely unwind the power cable. Also check power cable entry points, plugs and socket couplers for kinks.

### **The machine is intended for private use i.e. for use in home and gardening environments.**

The operating instructions as supplied by the manufacturer must be kept and referred to in order to ensure that the machine is properly used and maintained. The instructions contain valuable information on operating, maintenance and servicing conditions.

For safety reasons, the machine may not be used as a drive unit for other work tools or tool sets of and kind.

## 5. Assembly

### See Fig. D-K

Place the motor unit and the push bars on the ground in order (Fig. D). Important. Do not forget to slide the cable strain-relief clamp (Fig. F/Item 5) over the bottom push bar. Slide the bottom push bar on to the push bar holder and secure the two components to each other (Fig. E). Now secure the top push bar to the bottom push bar (Fig. F). Install the 2-hand safety switch as shown in (Fig. G-J/Item 6). Secure the cable using the supplied cable securing clips (Fig.K/A).

## 6. Starting up

Secure the power cable with the strain-relief clamp (Fig L/Item 2).

### **Important!**

To prevent accidental start-up of the machine, the push-bar (Fig. M/Item 1) is equipped with a two-point switch (Fig. M/Item 2) which must be pressed before the lever switch (Fig. M/Item 3) can be pressed. If the lever switch is released, the machine switches off. Repeat this process several times so that you are sure that your machine functions properly. Before you perform any repair or maintenance work on the machine, ensure that the tiller blades are not rotating and that the power supply is disconnected.

Always ensure that a safe distance (provided by the long handles) is maintained between the machine and the user. Be especially careful when changing direction on slopes and inclines. Maintain a solid footing and wear sturdy, non-slip footwear and long trousers. Always till along the incline (not up and down).

Use special caution when backing up and pulling the machine (tripping hazard).

## 7. Tips for proper working

Place the machine in front of the area you wish to till and hold it securely on the push bar before you switch on the machine. Guide the tiller blades over the area.

To achieve cleanly tilled soil always ensure that you guide the machine in straight lines wherever possible. Ensure that the tiller blades (Fig. A/Item 4) will always overlap each other by a few centimeters in order to avoid bare strips.

Switch off the motor promptly when you arrive at the end of the area you wished to till. The motor must be switched off when you raise the machine (for example to change direction).

Keep the underside of the machine clean and remove soil deposits. Deposits make it more difficult to start the machine and decrease the working depth. Work perpendicular to the slope on inclined areas. The machine must be switched off and the mains cable disconnected before you make any checks on the tiller blades.

### **Important!**

The tiller blades will continue to rotate for a few seconds after the motor is switched off. Never attempt to manually stop them. In the event that the rotating tiller blade strikes an object, immediately switch off the machine and wait for the tiller blades to come to a complete stop. Then inspect the condition of the tiller blades. Replace any parts that are damaged.

Lay the power cable on the ground in front of the outlet in a figure of 8. Work away from the outlet or cable and ensure that the power cable always trails in the tilled soil which will prevent the tiller blades from travelling over the cable.

## 8. Maintenance, care and storage

Maintenance and cleaning work on the machine as well as removal of the safety devices may only be performed when the motor is switched off and the power cable has been pulled. Worn out or damaged tiller blades should only be replaced by a professional/service workshop.

Do not clean the tool with running water - and particularly not with a pressure hose.

Ensure that all mounting components (i.e. screws, bolts, nuts etc.) are always tightened so that the machine can be safely operated at all times.

Store the device in a dry room. All the metal parts should be cleaned and then oiled to

ensure that they provide a long life. For best results, clean the plastic parts of the machine with a brush or rag. Do not use any solvents to remove dirt.

At the end of the season, perform a general inspection of the machine and remove any deposits which may have accumulated. At the start of each season, ensure that you check the condition of the machine. If repairs are necessary, please contact our customer service helpline (0151 649 1500).

## 9. Replace the tiller blades

For safety reasons, we recommend having the tiller blades replaced by a professional/service workshop (Spare parts can be ordered from [www.einhell.co.uk](http://www.einhell.co.uk) or calling 0151 649 1500).

### Important!

Wear working gloves. Use only genuine spare parts as otherwise the function and safety of the machine cannot be guaranteed.

## 10. Ordering replacement parts

Please quote the following data when ordering replacement parts:

- Type of machine (ER30)
- Article number of the machine (34.310.17)
- Identification number of the machine (11021)
- Replacement part number of the part required

### Helpline numbers:

UK 0151 649 1500

IRE 189 094 6244

## 4. Technical data

Voltage	230V ~ 50Hz
Power input	750 W
Working width	30 cm
Tiller diameter	22 cm
Idle speed	400 rpm
Number of blades	4 pieces
LpA noise level	70 dB(A)
LWA peak noise level	93 dB(A)
Vibration at the handlebars ahv	≤ 2.5 m/s <sup>2</sup>

## 12. Troubleshooting Guide

FAULT	POSSIBLE CAUSES	REMEDY
Motor does not start	a) No power at the plug b) Cable defective c) Switch/plug block defective d) Motor terminals or capacitor disconnected e) Excessive working depth	a) Check the power cable and fuse b) Check cable c) By customer service workshop d) By customer service workshop e) Reduce working depth
Motor performance drops	a) Soil too hard b) Blades badly worn	a) Correct working depth b) Replace tiller blades

### Important note!

**For protection, the motor is equipped with a thermal switch which cuts out when the motor is overloaded and switches on again automatically after a short cooling period.**

## Declaration of conformity

ISC GmbH · Eschenstraße 6 · D-94405 Landau/Isar



### Konformitätserklärung

- D** erklärt folgende Konformität gemäß EU-Richtlinie und Normen für Artikel
- GB** explains the following conformity according to EU directives and norms for the following product
- F** déclare la conformité suivante selon la directive CE et les normes concernant l'article
- I** dichiara la seguente conformità secondo la direttiva UE e le norme per l'articolo
- NL** verklaart de volgende overeenstemming conform EU richtlijn en normen voor het product
- E** declara la siguiente conformidad a tenor de la directiva y normas de la UE para el artículo
- P** declara a seguinte conformidade, de acordo com a directiva CE e normas para o artigo
- DK** attesterer følgende overensstemmelse i medfør af EU-direktiv samt standarder for artikel
- S** förklarar följande överensstämmelse enl. EU-direktiv och standarder för artikeln
- FI** vakuuttaa, että tuote täyttää EU-direktiivin ja standardien vaatimukset
- EE** tõendab toote vastavust EL direktiivile ja standarditele
- CZ** vydává následující prohlášení o shodě podle směrnice EU a norem pro výrobek
- SK** potvrjuje sledečo skladnost s smernico EU in standardi za izdelek
- SK** vydáva nasledujúce prehlásenie o zhode podľa smernice EÚ a noriem pre výrobok
- H** a cikkekhez az EU-irányvonal és Normák szerint a következő konformitást jelenti ki
- PL** deklaruje zgodność wymienionego poniżej artykułu z następującymi normami na podstawie dyrektywy WE.
- BG** декларира съответното съответствие съгласно Директива на ЕС и норми за артикул
- LV** paskaidro šādu atbilstību ES direktīvai un standartiem
- LT** apibūdina šį atitikimą EU reikalavimams ir prekės normoms
- RO** declară următoarea conformitate conform directivei UE și normelor pentru articolul
- GR** δηλώνει την ακόλουθη συμμόρφωση σύμφωνα με την Οδηγία ΕΚ και τα πρότυπα για το προϊόν
- HR** potvrđuje sljedeću usklađenost prema smjernicama EU i normama za artikl
- BN** potvrđuje sljedeću usklađenost prema smjernicama EU i normama za artikl
- RS** potvrđuje sledeću usklađenost prema smernicama EZ i normama za artikal
- RS** следуюцим удостоверяется, что следующие продукты соответствуют директивам и нормам ЕС
- UKR** проголошує про зазначену нижче відповідність виробу директивам та стандартам ЄС на виріб
- MK** ja izjavува следната сообрзност согласно EУ-директивата и нормите за артикли
- TR** Ürünü ile ilgili AB direktifleri ve normları gereğince aşağıda açıklanan uygunluğu belirtir
- N** erklærer følgende samsvar i henhold til EU-direktivet og standarder for artikkel
- IS** Lýsir uppfyllingu EU-reglna og annarra staðla vöru

### Electric Tiller ER30 (Qualcast)

- 87/404/EC\_2009/105/EC
- 2005/32/EC\_2009/125/EC
- 2006/95/EC
- 2006/28/EC
- 2004/108/EC
- 2004/22/EC
- 1999/5/EC
- 97/23/EC
- 90/396/EC\_2009/142/EC
- 89/686/EC\_96/58/EC
- 2011/65/EC
- 2006/42/EC
- Annex IV  
Notified Body:  
Notified Body No.:  
Reg. No.:
- 2000/14/EC\_2005/88/EC
- Annex V
- Annex VI  
Noise: measured  $L_{WA} = 86$  dB (A); guaranteed  $L_{WA} = 93$  dB (A)  
 $P = 0.75$  KW;  $L/\varnothing = 22$  cm  
Notified Body:
- 2004/26/EC  
Emission No.:

Standard references: EN 60335-1; EN 709; EN 55014-1;  
EN 55014-2; EN 61000-3-2; EN 61000-3-3

Landau/Isar, den 23.09.2011

Weichselgartner/General Manager

Gao/Product-Management

First CE: 11  
Art.-No.: 34.310.17 I.-No.: 11021  
Subject to change without notice

Archive-File/Record: NAPR004938  
Documents registrar: Alexander Scheiff  
Wiesenweg 22, D-94405 Landau/Isar

## Disposal

### For EU countries only



Never place any electric tools in your household refuse. To comply with European Directive 2002/96/EC concerning old electric and electronic equipment and its implementation in national laws, old electric tools have to be separated from other waste and disposed of in an environment-friendly fashion, e.g. by taking to a recycling depot.

Recycling alternative to the demand to return electrical devices:

As an alternative to returning the electrical device, the owner is obliged to cooperate in ensuring that the device is properly recycled if ownership is relinquished. This can also be done by handing over the used device to a returns center, which will dispose of it in accordance with national commercial and industrial waste management legislation. This does not apply to the accessories and auxiliary equipment without any electrical components which are included with the used device.

# PRODUCT GUARANTEE

---

**This product is guaranteed against manufacturing defects for a period of**



**Year**

This product is guaranteed for twenty four months from the date of original purchase. Any defects that arises due to faulty materials or workmanship will either be replaced, refunded or repaired free of charge where possible during this period by the dealer from whom you purchased the unit.

The guarantee is subject to the following provisions:

- The guarantee does not cover accidental damage, misuse, cabinet parts, knobs or consumable items.
- The product must be correctly installed and operated in accordance with the instructions contained in this manual.
- It must be used solely for domestic purpose.
- The guarantee will be rendered invalided if the product is re-sold or has been damaged by inexpert repair.
- Specifications are subject to change without notice.
- The manufacture disclaims any liability for the incidental or consequential damages.
- The guarantee is in addition to, and does not diminish your statutory or legal rights.

Guarantor: Home Retail Group  
AVEBURY MILTON KEYNES, MK9 2NW

For technical support and assistance or requests for spare parts and accessories please contact 0151 649 1500 between the following hours:  
Mon - Thursday 8.45am - 5.00pm    Friday 8.45am - 3.15pm

**Helpline No. UK 0151 649 1500 / IRE 189 094 6244**

# NOTES



# QUALCAST

## AFTER SALES SUPPORT

---

UK / IRELAND HELPLINE NO 0151 6491500  
REP. IRELAND HELPLINE NO 1890 946244  
WEB SUPPORT [www.einhell.co.uk](http://www.einhell.co.uk)

---

**MODEL NUMBER: ER30**  
**HOMEBASE ARTICLE NUMBER: 323439**