

**Einhell®**

Ⓒ **Operating Instructions**  
**Petrol Hedge Trimmer**

**7**

**Art.-Nr.: 34.038.45**

**I.-Nr.: 11011**

**BG-PH 2250**



Ⓢ Read and follow the operating instructions and safety information before using for the first time.

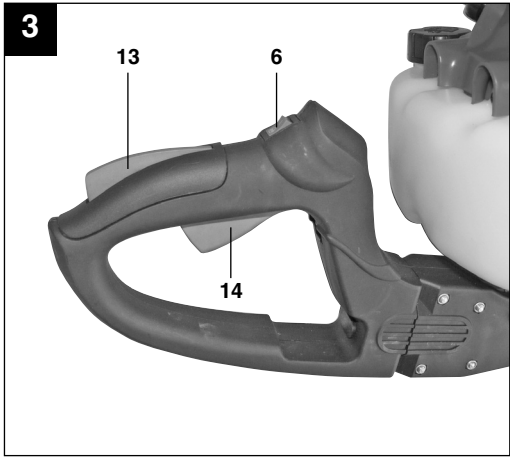
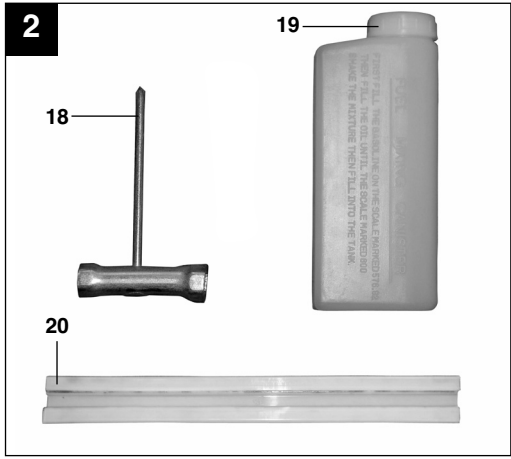
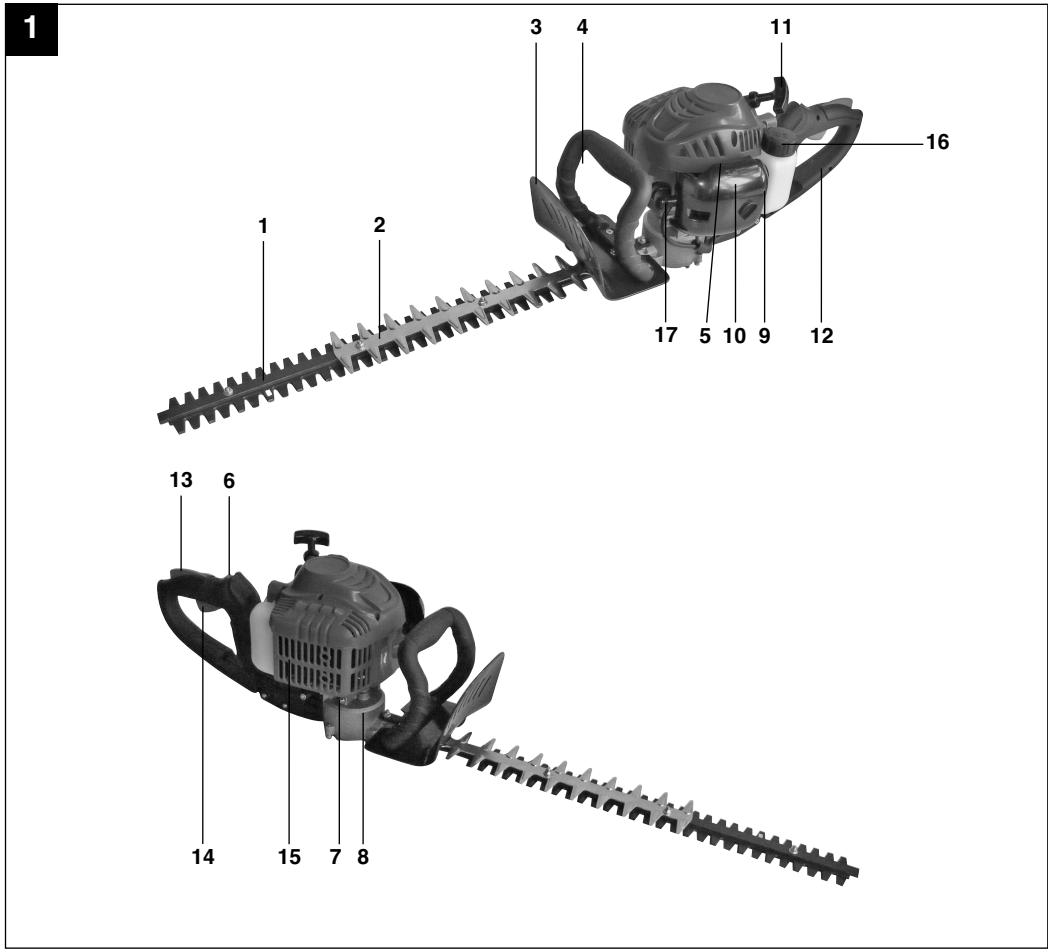

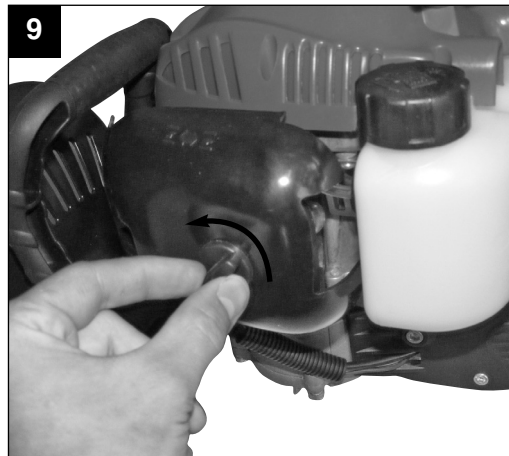
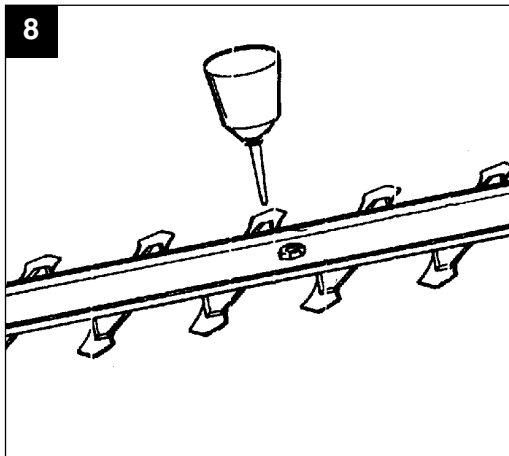
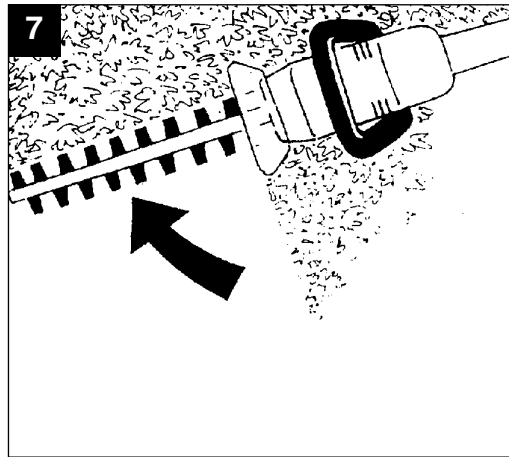
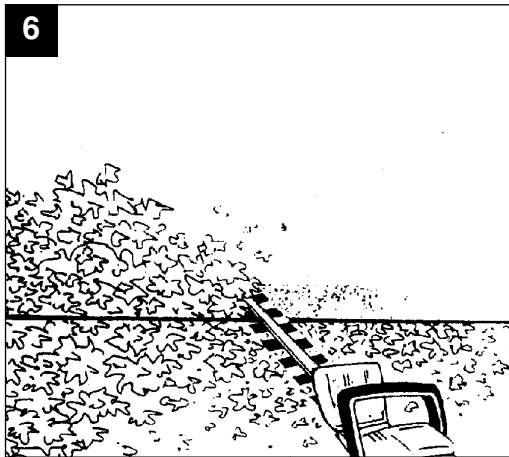
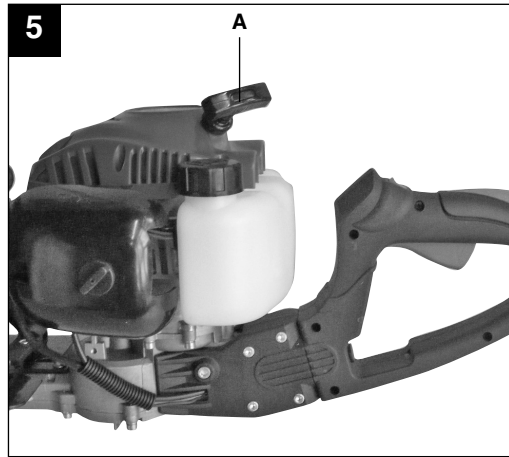
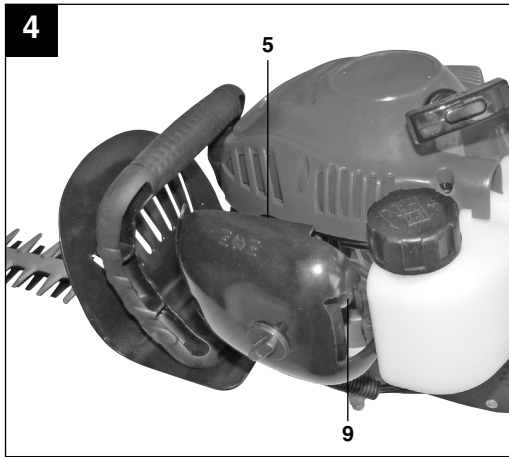

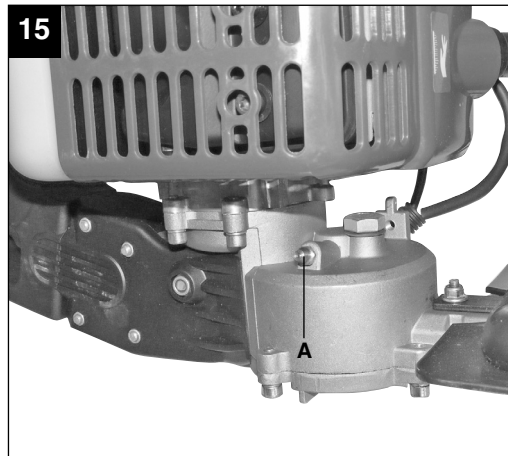
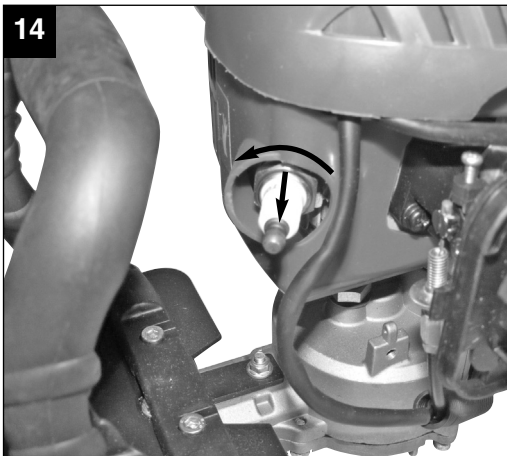
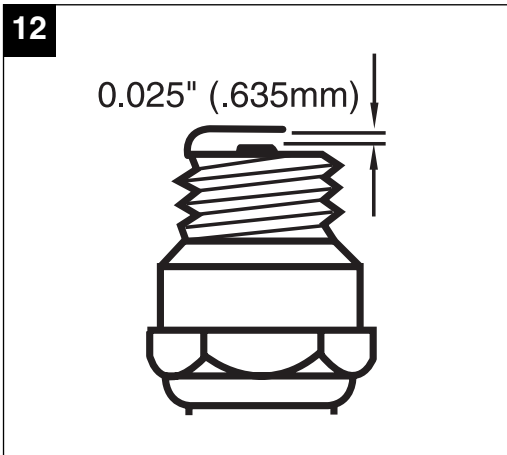
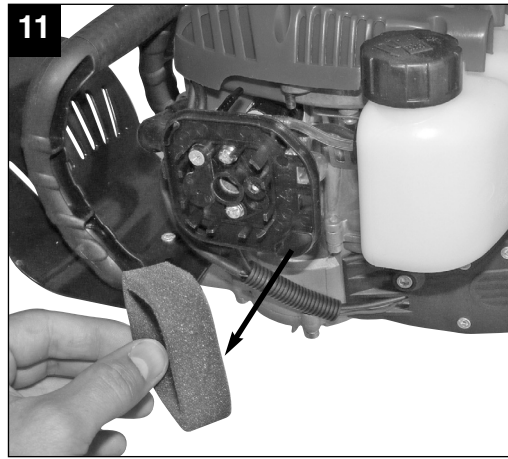
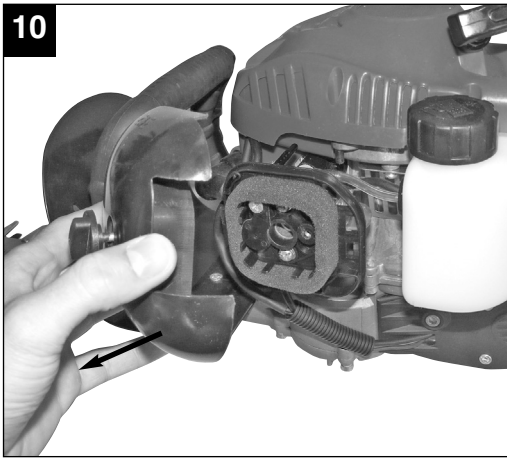

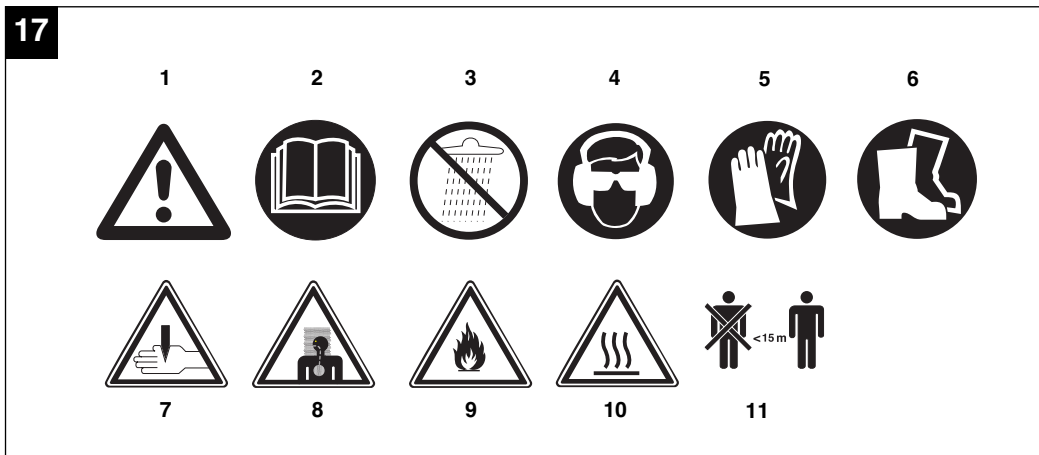
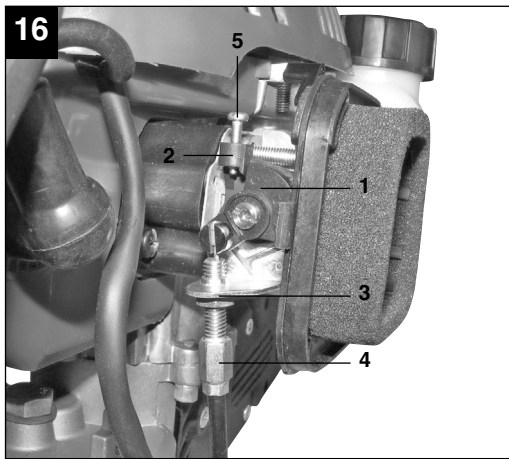

**⚠ Important!**

When using the equipment, a few safety precautions must be observed to avoid injuries and damage. Please read the complete operating instructions and safety regulations with due care. Keep this manual in a safe place, so that the information is available at all times. If you give the equipment to any other person, hand over these operating instructions and safety regulations as well. We cannot accept any liability for damage or accidents which arise due to a failure to follow these instructions and the safety instructions.

**1. Safety regulations**

The corresponding safety information can be found in the enclosed booklet.

**⚠ CAUTION!**

**Read all safety regulations and instructions.**

Any errors made in following the safety regulations and instructions may result in an electric shock, fire and/or serious injury.

**Keep all safety regulations and instructions in a safe place for future use.**

**Explanation of the warning signs on the equipment (see Fig. 17)**

1. Warning!
2. Read the directions for use before operating the equipment.
3. Do not expose the hedge trimmer to rain or wet conditions.
4. Wear eye protection and ear plugs.
5. Wear safety gloves.
6. Wear sturdy, non-slip footwear.
7. Caution: Sharp blades! Always keep hands and feet away from the blades.
8. Operate and start the equipment only outdoors in well ventilated areas to reduce the danger of injury from toxic gases.
9. Explosive material.
10. Very hot surface. Do not touch the hot exhaust silencer, gearbox or cylinder. You may burn yourself. These parts have become very hot during operation and remain very hot over a long period even after the equipment has been switched off.
11. Maintain a distance of at least 15 m from other persons.

**2. Layout and items supplied (Fig. 1-2)**

1. Cutting blade
2. Cutting blade safety cover
3. Safety plate
4. Front handle
5. Choke lever
6. ON/OFF switch
7. Lubrication nipple
8. Gears
9. Fuel pump (primer)
10. Air filter cover
11. Starter handle
12. Rear handle
13. Throttle lever "release"
14. Throttle lever
15. Silencer cover
16. Tank for fuel mixture
17. Spark plug boot
18. Spark plug wrench
19. Combined oil/petrol cylinder
20. Cutter rail cover

**3. Proper use**

**Important.** This hedge trimmer is suitable for cutting hedges, bushes and shrubs.

Please note that our equipment has not been designed for use in commercial, trade or industrial applications. Our warranty will be voided if the equipment is used in commercial, trade or industrial businesses or for equivalent purposes.

The machine is to be used only for its prescribed purpose. Any other use is deemed to be a case of misuse. The user / operator and not the manufacturer will be liable for any damage or injuries of any kind caused as a result of this.

**GB**

## 4. Technical data

Engine type:

2-stroke engine, air-cooled, chrome cylinder

Engine output (max.):	0.65 kW / 0.9 hp
Displacement:	22 ccm
Idle speed of engine:	3000 min <sup>-1</sup>
Max. engine speed	8500 min <sup>-1</sup>
Weight (with empty tank):	5.6 kg
Cutting length:	50 cm
Tooth spacing:	28 mm
Vibration (front handle) a <sub>hv</sub>	7.63 m/s <sup>2</sup>
Vibration (rear handle) a <sub>hv</sub>	5.01 m/s <sup>2</sup>
Sound pressure level L <sub>pA</sub>	95 dB
Sound power level L <sub>WA</sub>	106 dB

Sound and vibration were measured in accordance with DIN EN 10517.

## 5. Before starting the machine

### 5.1 Fuel and oil

#### Recommended fuels

Use only a mixture of normal unleaded petrol and special 2-stroke engine oil. Mix the fuel mixture as indicated on the fuel mixing table.

**Please note:** Do not use a fuel mixture which has been kept for longer than 90 days.

**Please note:** Do not use 2-stroke oil with a recommended mixing ration of 100:1. If inadequate lubrication causes engine damage, the manufacturer's engine warranty will be voided.

**Please note:** Only use containers designed and approved for the purpose to transport and store fuel.

Pour the correct quantities of petrol and 2-stroke oil into the mixing bottle (see scale printed on the bottle). Then shake the bottle well.

### 5.2 Fuel mixture table

Mixing procedure: 40 parts petrol to 1 part oil

Petrol	2-stroke oil
1 liters	25 ml
5 liters	125 ml

## 6. Operation

Please note that the statutory regulations governing noise abatement may differ from town to town.

### 6.1 Starting the engine from cold (Fig. 3-5)

Fill the tank with the required amount of oil/petrol mix.

1. Set the machine down on a hard, level surface.
  2. Set the choke lever (Fig. 4/Item 5) to "F".
  3. Press the fuel pump (primer) (Fig. 4/Item 9) 10 times.
  4. Move the ON/OFF switch (Fig. 3/Item 6) to "I".
  5. Set the throttle lever to full throttle. To do so, press the throttle lock (Fig. 3/Item 13).
  6. With the other hand pull out the starter cable (Fig. 5/Item A) until you feel it starts to resist. Now pull the starter cable repeatedly until the equipment starts up.
- Important:** Never allow the starter cable to snap back. This may damage the equipment.
7. If the engine has started, set the choke lever immediately to "H" and allow the machine to warm up for approx. 10 seconds.
  8. If the engine does not start up, repeat steps 6-7 above.

**Please note:** If the engine does not start up even after several attempts, read the section "Engine Troubleshooting".

**Please note:** Always pull the starter cable out in a straight line. If it is pulled out at an angle, then friction will occur on the eyelet. As a result of this friction, the cable will become frayed and will wear away faster.

### 6.2 Starting the engine when warm (if the machine has not been switched off for more than 15 – 20 minutes)

1. Set the machine down on a hard, level surface.
2. Switch the ON/OFF switch to "I".
3. Hold the machine by the front handle in your right hand and pull the starter cable up to the first resistance point (approx. 10 cm). Then tug sharply on the starter cable. The machine should start after 1-2 tugs. If the machine does not start after 6 pulls, repeat steps 1 – 7 of the procedure for starting the engine from cold.

### 6.3 Switching off the engine

Emergency Stop procedure:

If it becomes necessary to stop the machine immediately, set the ON/OFF switch to "Stop" or "0"



Normal procedure:

Let go of the throttle lever and wait until the engine has changed to idling speed. Then set the ON/OFF switch to "Stop" or "0".

#### 6.4 Practical tips

Never allow the machine to run at low speed for starting or for cutting.

**Cutting for dense growth:** The most effective method is to use wide, sweeping movements, guiding the cutting edge of the blade straight through the branches. A slight incline of the blade downwards towards the movement will produce best cutting results.

It is recommended to tie a guide line of string or the like along the hedge so that you cut the hedge to a level height. The branches above it will be cut off. (Fig. 6)

**Cutting the side of a hedge:** Cut the sides of the hedge with curve-shaped movements from the bottom up. (Fig. 7)

**Please note:** As a result of its design, if you work with the machine on its side for a lengthy period and the tank not completely filled, the motor may stall.

## 7. Cleaning, maintenance, storage and ordering of spare parts

### 7.1 Cleaning

- Keep all safety devices, air vents and the motor housing free of dirt and dust as far as possible. Wipe the equipment with a clean cloth or blow it with compressed air at low pressure.
- We recommend that you clean the device immediately each time you have finished using it.
- Clean the equipment regularly with a moist cloth and some soft soap. Do not use cleaning agents or solvents; these could attack the plastic parts of the equipment. Ensure that no water can seep into the device.

### 7.2 Maintenance

Always switch off the head trimmer and remove the spark plug boot before carrying out any maintenance work.

1. The cutter blades are high quality, made of tempered steel and in normal use there is no need to sharpen the blades. If you accidentally strike a wire, stone, glass or other hard object,

this may cause a notch in the blade. There is no need to remove the notch as long as it does not adversely affect the movement of the cutting edges. If it does adversely affect this movement, switch off the machine and use a fine file or a fine grinding stone to remove the notch. Ensure that the blade's cutting edge is always well oiled (see Fig. 8).

2. If you drop the hedge trimmer, check whether it has suffered any damage. If it is damaged contact an authorized customer service outlet or send the machine to ISC GmbH to have it repaired.
3. Only clean the machine after it has been switched off. Use only mild soap and a damp cloth to clean it. Never allow fluid to get into the machine. Do not use caustic cleaning products.

#### 7.2.1 Maintenance of the air filter (Fig. 9-11)

Soiled air filters reduce the engine output by supply too little air to the carburetor.

Regular checks are therefore essential. The air filter should be checked after every 25 hours of use and cleaned if necessary. If the air contains a lot of dust, the air filter should be checked more frequently.

1. Remove the air filter cover (Fig. 9-10)
2. Remove the filter element (Fig. 11)
3. Clean the filter element by tapping it or blowing it.
4. Assemble in reverse order.

**Please note:** Never clean the air filter with petrol or inflammable solvents. Clean the air filter with compressed air or by tapping it.

#### 7.2.2 Maintenance of the spark plug (Fig. 12-14)

Spark plug gap = 0.025 inch (0.635 mm). Tighten the spark plug with a torque of 12-15 Nm.

Check the spark plug for dirt and grime after 10 hours of operation and if necessary clean it with a copper wire brush. Thereafter service the spark plug after every 50 hours of operation.

1. Pull off the spark plug boot (Fig. 13) by twisting.
2. Remove the spark plug (Fig. 14) with the supplied spark plug wrench.
3. Assemble in reverse order.

#### 7.2.3 Maintenance of the gearbox (Fig. 15)

The gearbox must be lubricated every year before the start of the season at the lubrication nipple (Fig. 15/Item A). Place a conventional grease gun on the nipple and press approx. 3 strokes of conventional machine grease into the gearbox. If you use the trimmer frequently, grease the gearbox more often.

**GB**

### 7.2.4 Carburetor settings

**Important.** Settings on the carburetor may only be made by authorized customer service personnel. The air filter cover must be removed before any work on the carburetor, as shown in Figures 9 – 10.

#### Setting the throttle cable:

If the maximum speed of the machine falls over time and you have ruled out all the other causes listed in section 9 Troubleshooting, it may be necessary to adjust the throttle cable.

First of all check whether the carburetor opens fully when the throttle handle is pressed fully. This is the case if the carburetor slide (Fig. 16/Item 1) rests against the stop (Fig. 16/Item 2) when the throttle is fully open. Figure 16 shows the correct setting. If the carburetor slide does not touch the stop, it must be adjusted.

The following work is required to adjust the throttle cable:

- Undo the lock nut (Fig. 16/Item 3) a few turns.
- Undo the adjusting screw (Fig. 16/Item 4) until the carburetor slide rests against the stop when the throttle is fully open, as shown in Figure 16.
- Retighten the lock nut.

#### Setting the idling speed:

**Important.** Set the idling speed when the machine is warm.

If the engine stalls when the throttle is not pressed and you have ruled out all the other causes listed in section 9 Troubleshooting, the idling speed must be adjusted. To do this turn the idling speed screw (Fig. 16/Item 5) clockwise until the machine runs smoothly at idling speed.

If the idling speed is so fast that the cutting blades do not reach a standstill, the idling speed must be reduced by turning the idling speed screw (Fig. 16/Item 5) counterclockwise until the cutting blades stop.

### 7.3 Storage

**Please note:** If you fail to follow these instructions correctly, deposits may form on the interior of the carburetor which may result in the engine being more difficult to start or the machine suffering permanent damage.

1. Carry out all the maintenance work.
2. Drain the fuel out of the tank (use a conventional plastic petrol pump from a DIY store for this purpose).
3. When the fuel has been drained, start the engine.
4. Allow the engine to run at idling speed until it

10

stops. This will clean the remainder of the fuel out of the carburetor.

5. Leave the machine to cool (approx. 5 minutes).
6. Remove the spark plug (see point 7.2.2).
7. Place a teaspoon full of 2-stroke engine oil into the combustion chamber. Pull the starter cable several times carefully to wet the internal components with the oil. Fit the spark plug again.
8. Clean the exterior housing of the machine.
9. Store the machine in a cold, dry place where it is out of the reach of ignition sources and inflammable substances.

Fertilizers and other chemical garden products often contain substances that accelerate the rate of corrosion of metals. Do not store the machine on or near fertilizers or other chemicals.

#### Restarting

1. Remove the spark plug.
2. Pull the starter cable several times to clean the oil residue out of the combustion chamber.
3. Clean the spark plug contacts or fit a new spark plug.
4. Fill the tank. See the section entitled Fuel and oil.
5. Complete steps 1-7 described under the point entitled "Starting the engine from cold".

### 7.4 Ordering replacement parts

Please quote the following data when ordering replacement parts:

- Type of machine
- Article number of the machine
- Identification number of the machine
- Replacement part number of the part required

For our latest prices and information please go to [www.einhell.com.au](http://www.einhell.com.au)

## 8. Disposal and recycling

The unit is supplied in packaging to prevent its being damaged in transit. This packaging is raw material and can therefore be reused or can be returned to the raw material system.

The unit and its accessories are made of various types of material, such as metal and plastic. Defective components must be disposed of as special waste. Ask your dealer or your local council.

## 9. Troubleshooting

Fault	Possible cause	Troubleshooting
The machine does not start.	Correct starting procedure not followed.	Follow the instructions for starting.
	Sooted or damp spark plug	Clean the spark plug or replace it with a new one.
	Incorrect carburetor setting	Contact an authorized customer service outlet or send the machine to ISC-GmbH.
The machine starts but does not develop its full output.	Incorrect choke lever setting	Set choke lever to $\text{H}$
	Soiled air filter	Clean the air filter
	Incorrect carburetor setting	Contact an authorized customer service outlet or send the machine to ISC-GmbH.
The engine does not run smoothly	Incorrect electrode gap on the spark plug	Clean the spark plug and adjust the electrode gap or fit a new spark plug.
	Incorrect carburetor setting	Contact an authorized customer service outlet or send the machine to ISC-GmbH.
Engine smokes excessively	Incorrect fuel mix	Use the correct fuel mix (see fuel mixing table)
	Incorrect carburetor setting	Contact an authorized customer service outlet or send the machine to ISC-GmbH.

The guarantee provided in this Guarantee Certificate is given by Einhell Australia Pty Limited  
ACN 134 632 858 of 6/166 Wellington Street, Collingwood, Victoria (Telephone number 1300 922 271)  
(Einhell Express Guarantee).

## GUARANTEE CERTIFICATE

Dear Customer,

All of our products undergo strict quality checks. In the unlikely event that your device develops a fault, please contact our service department at the address shown on this guarantee certificate. Of course, if you would prefer to call us then we are also happy to offer our assistance under the service number printed below. Please note the following terms under which claims under the Einhell Express Guarantee can be made:

1. The benefits conferred by the Einhell Express Guarantee are in addition to all rights and remedies which you may be entitled to under the Australian Consumer Law, and any other statutory rights you may have under other applicable laws. This Einhell Express Guarantee does not exclude, restrict or modify any such rights or remedies.

We do not charge you for the Einhell Express Guarantee.

2. Our goods come with guarantees that cannot be excluded under the Australian Consumer Law. You are entitled to a replacement or refund for a major failure and for compensation for any other reasonably foreseeable loss or damage. You are also entitled to have the goods repaired or replaced if the goods fail to be of acceptable quality and the failure does not amount to a major failure.
3. The Einhell Express Guarantee only covers problems caused by material or manufacturing defects, and our liability under the Einhell Express Guarantee is limited, at our discretion, to the rectification of these defects or replacement of the product. Please note that the product has not been designed for use in commercial, trade or industrial applications. Consequently, the Einhell Express Guarantee will not apply if the product is used in commercial, trade or industrial applications or for other equivalent activities.
4. The following are also excluded from the Einhell Express Guarantee: compensation for transport damage, damage caused by failure to comply with the installation/assembly instructions or damage caused by unprofessional installation, failure to comply with the operating instructions (e.g. connection to the wrong mains voltage or current type), misuse or inappropriate use (such as overloading of the product or use of non-approved tools or accessories), failure to comply with the maintenance and safety regulations, ingress of foreign bodies into the product (e.g. sand, stones or dust), effects of force or external influences (e.g. damage caused by the product being dropped) and normal wear resulting from proper operation of the product. The Einhell Express Guarantee will also not apply if any attempt is made to tamper with the product.
5. The Einhell Express Guarantee is valid for a period of 2 years starting from the purchase date of the product. Claims made under the Einhell Express Guarantee should be submitted before the end of this guarantee period and within two weeks of the defect being noticed. No claims under the Einhell Express Guarantee will be accepted if submitted after the end of this guarantee period. The original guarantee period remains applicable to the device even if repairs are carried out or parts are replaced. In such cases, the work performed or parts fitted will not result in an extension of the guarantee period for the Einhell Express Guarantee, and the Einhell Express Guarantee will not apply for the work performed or parts fitted. This also applies when an on-site service is used.
6. To make a claim under the Einhell Express Guarantee, please send the relevant product postage-free to the address shown below and enclose either the original or a copy of your sales receipt or another dated proof of purchase. It would help us if you could describe the nature of the problem in as much detail as possible. If the defect is covered by the Einhell Express Guarantee, your product will be repaired immediately and returned to you, or we will send you a new device (at our election).

Any costs incurred by you in making a claim under this Einhell Express Guarantee, unless specified otherwise in this guarantee certificate, must be borne by you.

Of course, we are also happy to offer a chargeable repair service for any defects which are not covered by the scope of the Einhell Express Guarantee or for products which are no longer covered by the Einhell Express Guarantee. To take advantage of this service, please send the product to our service address.

EINHELL AUSTRALIA PTY LTD  
6/166 Wellington Street  
Collingwood VIC 3066  
Australia  
Phone: 1300 922 271