



10.8V LI-ION
CORDLESS DRILL



INSTRUCTION MANUAL

MODEL NUMBER BT-CD 10.8/3 Li

AFTER SALES SUPPORT

TEL: 1300 922 271

EMAIL: service.australia@einhell.com

✓ N26704

Cordless Lithium-Ion Cordless Drill

What your 3 year warranty means

Great care has gone into the manufacture of this product and it should therefore provide you with years of good service when used properly. In the event of product failure within its intended use over the course of the first 3 years after the date of purchase, we will remedy the problem as quickly as possible once it has been brought to our attention. In the unlikely event of such an occurrence, or if you require any information about the product, please contact us via our after sales support services, details of which can be found in this manual and on the product itself.

Welcome Section

Congratulations on choosing to buy a TAURUS TITANIUM® product. All products brought to you by TAURUS TITANIUM® are manufactured to the highest standards of performance and safety, and, as part of our philosophy of customer service and satisfaction, are backed by our comprehensive 3 Year Warranty.

We hope you will enjoy using your purchase for many years to come.

Table of Contents

1. Safety regulations
2. Layout and items supplied
3. Proper use
4. Technical data
5. Before starting the machine
6. Operation
7. Cleaning, maintenance and ordering of spare parts
8. Disposal and recycling

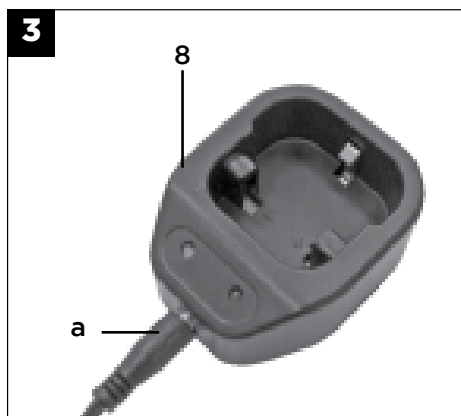

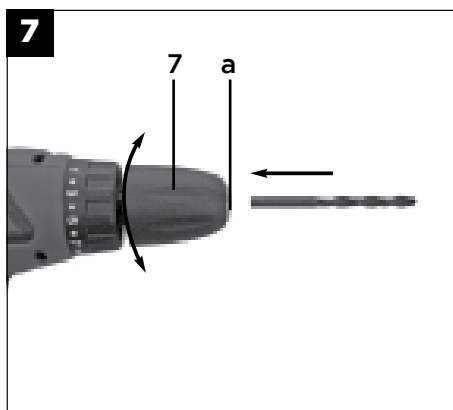
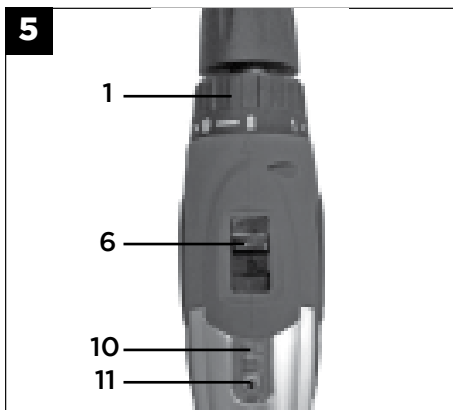
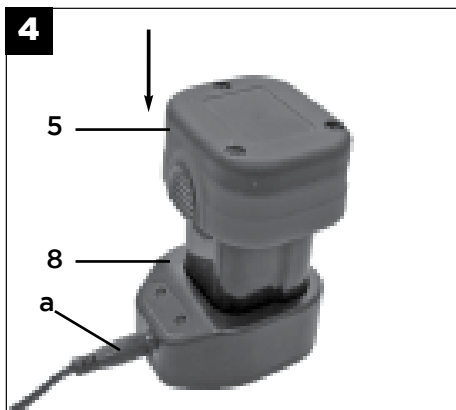

Caution

Read the operating instructions to reduce the risk of injury.



Wear ear-muffs.

The impact of noise can cause damage to hearing.



Wear safety goggles.

Sparks generated during working or splinters, chips and dust emitted by the device can cause loss of sight.



Wear a breathing mask.

Dust which is injurious to health can be generated when working on wood and other materials. Never use the device to work on any materials containing asbestos!

GENERAL SAFETY RULES

WARNING! Read all instructions. *Failure to follow all instructions listed below may result in electric shock, fire and/or serious injury. The term "power tool" in all of the warnings listed below refers to your mains-operated (corded) power tool or battery-operated (cordless) power tool.*

SAVE THESE INSTRUCTIONS

1. Work area

- a. **Keep work area clean and well lit.** *Cluttered and dark areas invite accidents.*
- b. **Do not operate power tools in explosive atmospheres,** such as in the presence of flammable liquids, gases or dust. *Power tools create sparks which may ignite the dust or fumes.*
- c. **Keep children and bystanders away while operating a power tool.** *Distractions can cause you to lose control.*

2. Electrical safety

- a. **Power tools plugs must match the outlet.** *Never modify the plug in any way. Do not use any adapter plugs with earthed (grounded) power tool. Unmodified plugs and matching outlets will reduce risk of electric shock.*
- b. **Avoid body contact with earthed or grounded surfaces such as pipes, radiators, ranges and refrigerators.** *There is an increased risk of electric shock if your body is earthed or grounded.*
- c. **Do not expose power tools to rain or wet conditions.** *Water entering a power tool will increase the risk of electric shock.*
- d. **Do not abuse the cord.** *Never use the cord for carrying, pulling or unplugging the power tool. Keep cord away from heat, oil, sharp edges or moving parts. Damaged or entangled cords increase the risk of electric shock.*
- e. **When operating a power tool outdoors, use an extension cord suitable for outdoor use.** *Use of a cord suitable for outdoor use reduces the risk of electric shock.*

3. Personal safety

- a. **Stay alert, watch what you are doing and use common sense when operating a power tool.** *Do not use a power tool while you are tired or under the influence of drugs, alcohol or medication. A moment of inattention while operating power tools may result in serious personal injury.*
- b. **Use safety equipment.** *Always wear eye protection. Safety equipment such as dust mask, non-skid safety shoes, hard hat, or hearing protection used for appropriate conditions will reduce personal injuries.*
- c. **Avoid accidental starting.** *Ensure the switch is in the off-position before plugging in. Carrying power tools with your finger on the switch or plugging in power tools that have the switch on invites accidents.*

- d. **Remove any adjusting key or wrench before turning the power tool on.** *A wrench or a key left attached to rotating part of the power tool may result in personal injury.*
- e. **Do not overreach.** *Keep proper footing and balance at all times. This enables better control of the power tool in unexpected situations.*
- f. **Dress properly.** *Do not wear loose clothing or jewellery. Keep your hair, clothing and gloves away from moving parts. Loose clothes, jewellery or long hair can be caught in moving parts.*
- g. **If devices are provided for the connection of dust extraction and collection facilities, ensure these are connected and properly used.** *Use of these devices can reduce dust-related hazards.*

4. Power tool use and care

- a. **Do not force the power tool.** *Use the correct power tool will do the job better and safer at the rate for which it was designed.*
- b. **Do not use the power tool if the switch does not turn it on and off.** *Any power tool that cannot be controlled with the switch is dangerous and must be repaired.*
- c. **Disconnect the plug from the power source and/or the battery pack from the power tool before making any adjustments, changing accessories, or storing power tools.** *Such preventive safety measures reduce the risk of starting the power tool accidentally.*
- d. **Store idle power tools out of the reach of children and do not allow persons unfamiliar with the power tool or these instructions to operate the power tool.** *Power tools are dangerous in the hands of untrained users.*
- e. **Maintain power tools.** *Check for misalignment or binding of moving parts, breakage of parts and any other condition that may affect the power tools operation. If damaged, have the power tool repaired before use. Many accidents are caused by poorly maintained power tools.*
- f. **Keep cutting tools sharp and clean.** *Properly maintained cutting tools with sharp cutting edges are less likely to bind and are easier to control.*
- g. **Use the power tool, accessories and tool bits etc. in accordance with these instructions and in the manner intended for the particular type of power tool, taking into account the working conditions and the work to be performed.** *Use of the power tool for operations different from those intended could result in a hazardous situation.*

5. Service

- a. **Have your power tool serviced by a qualified repair person using only identical replacement parts.** *This will ensure that the safety of the power tool is maintained.*

Important!

When using equipment, a few safety precautions must be observed to avoid injuries and damage. Please read the complete operating manual with due care. Keep this manual in a safe place, so that the information is available at all times. If you give the equipment to any other person, give them these operating instructions as well.

We accept no liability for damage or accidents which arise due to non-observance of these instructions and the safety information.

1. Safety regulations

Please refer to the booklet included in delivery for the safety instructions.

CAUTION!

Read all safety regulations and instructions.

Any errors made in following the safety regulations and instructions may result in an electric shock, fire and/or serious injury.

Keep all safety regulations and instructions in a safe place for future use.

2. Layout (Fig. 1)

1. Torque selector
2. Changeover switch
3. ON/OFF switch
4. Battery pack
5. Pushlock button
6. Selector switch for 1st gear to 2nd gear
7. Quick-change drill chuck
8. Charging adapter
9. Battery charger
10. Battery capacity indicator
11. Switch for battery capacity indicator

3. Proper use

The cordless drill/screwdriver is designed for tightening and undoing screws, as well as for drilling in wood, metal and plastic.

The machine is to be used only for its prescribed purpose. Any other use is deemed to be a case of misuse. The user / operator and not the manufacturer will be liable for any damage or injuries of any kind caused as a result of this.

Please note that our equipment has not been designed for use in commercial, trade or industrial applications. Our warranty will be voided if the machine is used in commercial, trade or industrial businesses or for equivalent purposes.

4. Technical data

Motor power supply:	10.8V DC
Idling speed:	0-350 rpm 0-1200 rpm
Torque settings:	19 + 1
Forward and reverse rotation:	Yes
Chuck capacity:	10mm
Battery charging voltage:	12V DC
Battery charging current:	500 mA
Mains voltage for charger:	240V-50 Hz
Weight:	1.2 kg
Max. screw diameter:	6mm

Sound and Vibration

Sound and vibration values were measured in accordance with EN 60745.

L_{pA} sound pressure level	64 dB(A)
K_{pA} uncertainty	3 dB
L_{WA} sound power level	75 dB(A)
K_{WA} uncertainty	3 dB

Wear ear-muffs.

The impact of noise can cause damage to hearing.

Total vibration values (vector sum of three directions) determined in accordance with EN 60745.

Screwing without hammer action

Vibration emission value $a_h \leq 0,153 \text{ m/s}^2$

K uncertainty = $1,5 \text{ m/s}^2$

Important!

The vibration value changes according to the area of application of the electric tool and may exceed the specified value in exceptional circumstances.

Keep the noise emissions and vibrations to a minimum.

- Only use appliances which are in perfect working order.
- Service and clean the appliance regularly.
- Adapt your working style to suit the appliance.
- Do not overload the appliance.
- Have the appliance serviced whenever necessary.
- Switch the appliance off when it is not in use.
- Wear protective gloves.

5. Before starting the machine

Be sure to read the following information before you use your cordless drill for the first time:

1. Charge the battery pack with the charger supplied.
2. Only ever use screwdriver bits which are suitable for the purpose and in faultless condition.
3. Always check for concealed electric cables and gas and water pipes when drilling and screwing in walls.

Warning! Do not press the ON/OFF switch any more if the protective circuit has actuated. This may damage the battery.

6. Operation

6.1 Charging the LI battery pack (Fig. 2/3/4)

The battery is protected from exhaustive discharge. An integrated protective circuit automatically switches off the equipment when the battery is flat. In this case the bit chuck will cease to turn.

Warning! Do not press the ON/OFF switch any more if the protective circuit has actuated. This may damage the battery.

1. Remove the battery pack (4) from the handle, pressing the pushlock buttons (5) on the left and right sides to do so.
2. Check that your mains voltage is the same as that marked on the rating plate of the battery charger. Plug the mains plug of the charger (9) into the mains socket outlet.

1. Remove the battery pack (4) from the handle, pressing the pushlock buttons (5) on the left and right sides to do so.
2. Check that your mains voltage is the same as that marked on the rating plate of the battery charger. Plug the mains plug of the charger (9) into the mains socket outlet.
3. Connect the charging cable (a) to the charging adapter (8).
4. The green LED on the charger will come on. Plug the battery (4) into the charging adapter (8). Now the red LED will come on to indicate that the battery pack is being charged. When the charging period is completed after approx. 3 hours, the red LED goes out again. The temperature of the battery (4) may rise during the charging operation. This is normal.

If the battery pack fails to become charged, please check

- whether there is voltage at the socket-outlet
- whether there is good contact at the charging contacts of the battery station (8).

If the battery still fails to become charged, please return

- the charger and charging adapter
- the battery pack to our Customer Service Department.

To ensure that the LI battery pack provides long service you should take care to recharge it promptly. You must recharge the battery pack when you notice that the power of the cordless drill drops.

Never fully discharge the battery pack. This will cause the LI battery pack to develop a defect.

6.2 Torque setting (Fig. 5 / Item 1)

The cordless drill is fitted with a mechanical torque selector.

The torque for a specific size of screw is selected with the set-collar (1). The correct torque depends on several factors:

- on the type and hardness of material in question
- on the type and length screws used
- on the requirements needing to be met by the screwed joint.

The clutch disengages with a grating sound to indicate when the set torque is reached.

Important! The tool must be at a standstill when you set the torque with the setting ring.

6.3 Drilling (Fig. 5 / Item 1)

For drilling purposes, move the set-collar to the laststep "Drill". In this setting the slip clutch is inactive. The maximum torque is available in drilling mode.

6.4 Forward/Reverse switch (Fig. 6 / Item 2)

With the slide switch above the On/Off switch you can select the direction of rotation of the battery powered drill/screwdriver and secure it against being switched on accidentally. You can choose between clockwise and anticlockwise rotation. To avoid causing damage to the gearing it is advisable to change the direction of rotation only when the tool is at a standstill. The On/Off switch is blocked when the slide switch is in centre position.

6.5 On/Off switch (Fig. 6 / Item 3)

Infinitely variable speed control is possible with the On/Off switch. The further you press the switch, the higher the speed of the battery-powered drill/screwdriver.

6.6 Battery capacity indicator (Fig. 5/Item 10)

Press the button for the battery capacity indicator (11). The battery capacity indicator (10) indicates the charge state of the battery on 3 colored LEDs.

All LEDs illuminate:

The battery is fully charged.

The yellow and red LED illuminate:

The battery has an adequate remaining charge.

Red LED:

The battery is empty, recharge the battery.

6.7 Changing the tool (Fig. 7)

Important. Set the changeover switch (2) to its centre position whenever you carry out any work (for example changing the tool, maintenance work, etc.) on the cordless drill.

- The cordless drill is fitted with a quickaction chuck (7) with an automatic spindle stop.
- Open the chuck (7). The chuck opening (a) must be large enough to hold the tool (drill bit or screwdriver bit).
- Select the suitable tool. Push the tool as far as possible into the chuck opening (a).
- Tighten the chuck (7) and then check that the tool is secure.

6.8 Screwdriving

We recommend using self-centering screws (e.g. Torx screws, recessed head screws) designed for reliable working. Be sure to use a bit that matches the screw in shape and size. Set the torque, as described elsewhere in these operating instructions, to suit the size of screw.

6.9 Selecting 1st gear to 2nd gear (Fig. 5/Item 6)

By adjusting the selector switch, you can work with a faster or slower turning speed. Change the gear only when the drill is at a standstill. If you fail to observe this point, the gearing may be damaged.

7. Cleaning, maintenance and ordering of spare parts

Always pull out the mains power plug before starting any cleaning work.

7.1 Cleaning

- Keep all safety devices, air vents and the motor housing free of dirt and dust as far as possible. Wipe the equipment with a clean cloth or blow it with compressed air at low pressure.
- We recommend that you clean the device immediately each time you have finished using it.
- Clean the equipment regularly with a moist cloth and some soft soap. Do not use cleaning agents or solvents; these could attack the plastic parts of the equipment. Ensure that no water can seep into the device.

7.2 Maintenance

There are no parts inside the equipment which require additional maintenance.

8. Disposal and recycling

The unit is supplied in packaging to prevent its being damaged in transit. This packaging is raw material and can therefore be reused or can be returned to the raw material system.

The unit and its accessories are made of various types of material, such as metal and plastic. Defective components must be disposed of as special waste. Ask your dealer or your local council.

TAURUS TITANIUM® is a registered trademark of ALDI Stores.

ALDI Guarantee

Specially made for ALDI Stores to our stringent quality specifications. If you are not entirely satisfied with this product, please return it to your nearest ALDI store within 60 days from the date of purchase for a full refund or replacement, or take advantage of our after sales support by calling the Customer Service Hotline.

Einhell Australia Pty. Ltd.
6/166 Wellington St
Collingwood,
Victoria, 3066
Australia

01/2011