



Einhell

BLUE

BT-BD 401 Bench Drill

Art.-No. 42.504.20

Features

- Handles (1)
- Continuously adjustable table height (2)
- Stable foot with ground plate (3)
- Folding chip guard (4)
- Gear ring drill chuck (5)
- ON/OFF switch with zero voltage releasing
- Adjustable depth gauge for precise drilling (6)
- Tilttable and pivotable drill table
- 5-fold speed grading from 580 – 2,650 min⁻¹
- Ball bearing drill spindle

Technical Data

- Mains: 230 V ~ 50 Hz
- Power: 350 W S2 15 min
- Spindle speed: 580 – 2,650 min⁻¹ (5 steps)
- Tilt drill table: -45° to +45°
- Drill chuck mount: B16
- Drill diameter: Ø 1.5 - 13 mm
- Throat: 104 mm
- Max. drilling depth: 50 mm
- Product weight: 15.4 kg
- Gross weight: 16.4 kg
- Packing dimensions: 455 x 355 x 235 mm
- Bar code: 4006825 505047
- Sales unit: 1 pc

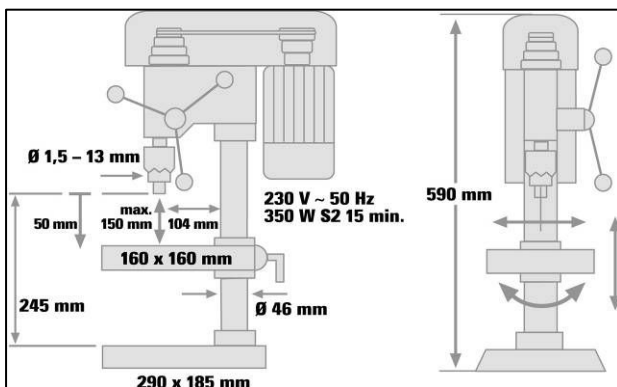

As special accessory available:

Bench vice

Art.-No.: 42.257.06

Bar code: 4006825 421002