



# Cross cut and mitre Saw with Laser KSL 250/2

Art.-No.: **43.001.17**

Bar code: 4006825513691

Sales unit: 1 pc

The cross-cut and mitre saw KSL 250/2 allows a quick and precise cutting of wood. With the tilting and turning saw head double mitre cuts are possible. The Mitre Saw with laser is equipped with an additional laser function for the highest cutting accuracy

### Features:

- Carbide tipped saw blade (1)
- Rotation table with precise angle setting for mitre cuts from -45° to +45° (2)
- incl. dust bag (3) and special locking for transport
- **inclusive Lasermodule (4)**
- Saw head can be tilted from 0° to +45° (5)
- With interlock settings at 15°, 22.5°, 30°, 45°, 90°
- Clamping device for fixing the work piece

### Technical data:

- Mains: 230 V ~ 50 Hz
- Power: 1.600 watts
- Idle speed n<sub>0</sub>: 4.600 min<sup>-1</sup>
- Carbide tipped saw blade: Ø 250 x Ø 30 x 3.0 mm
- Number of teeth: 60
- Tilting range: -45°/0°/+45°
- Mitre cutting: 0° to 45° to the left
- Cutting width 90° x 90°: 115 x 90 mm
- Cutting width 90° x 45°: 75 x 90 mm
- Cutting width 45° x 45°: 75 x 40 mm
- Double mitre cuts
- Weight: approx. 15.3 kg
- Packing dimension: 510 x 450 x 370 mm

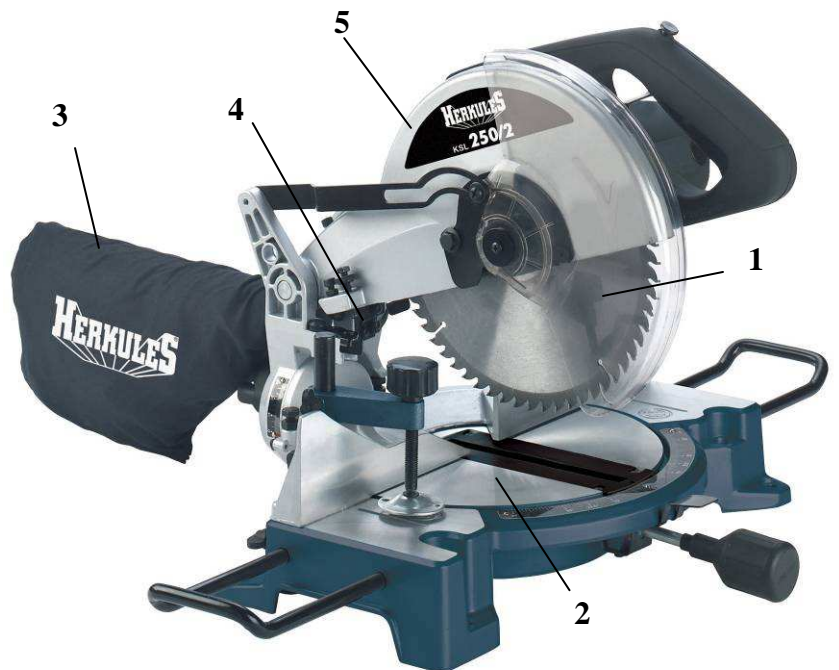

### As special accessory available:

Carbide tipped saw blade Ø 250 x Ø 30 x 3.0 mm 24 teeth	Art.-No.: <b>43.111.10</b> Bar code: <b>4006825431223</b>	Carbide tipped saw blade Ø 250 x Ø 30 x 3.0 mm 48 teeth	Art.-No.: <b>43.111.11</b> Bar code: <b>4006825431230</b>	Carbide tipped saw blade Ø 250 x Ø 30 x 3.0 mm 60 teeth	Art.-No.: <b>43.111.13</b> Bar code: <b>4006825503166</b>
---	---	---	---	---	---

Abbildungen können nicht im Serien-Lieferumfang enthaltenes Zubehör darstellen / Illustrations can contain accessories, which are not included in standard extent of delivery.

Abbildungen ähnlich, produktionsbedingte Abweichung vorbehalten / Illustration similar (in design), production-wise modifications reserved

File: K:\Webshop\T-Produktbeschreibung\60\Originale\_Englisch\_PA04\4300117\_01015.doc

Erstelldatum / create date: 07.09.2005 10:13:00

Aktualisiert / up dated: 28.09.2005