



Electric Hoist SHZ 1000

Art.-No.: **22.557.14**

Bar-Code: 4006825510393

Sales Unit: 1 pc

This powerful electric hoist is conform to the latest state of art based on the valid norms and legal standards of 1999. Due to the adaptation to the latest standards, several advantages should be noted:

- The start button is equipped with an **emergency-cut-off button**. This device guarantees a safe cut-off in case of failure of the start switch.
- The start button is designed in **insulation class II** (safety insulated).
- A **forcibly actuated end switch** assures that the hoist will safely be cut-off at the upper end (i. e. in case the 2 contacts stick together).
- **Improved brake:** In case of a defect on the pressure spring (i. e. rupture of the wire) stopping of the load still is assured.
- The brake will be activated in case of power failure in the motor.
- The **improved gear** warrants a longer service life of the drive unit.
- The **non-rotating steel rope** reduces twisting of the loads during the lifting motion.
- The load hook with **additional safety latch**: This added latch prevents an unintended loosening of the load suspension device.
- The **motor with overload protection** prevents it from overheating.

Features:

- Fastening with 2 double clamps (1)
- 12 m non-rotating (kinking) steel wire
Ø 5,6 mm (2)
- Motor with thermal cut-out (3)
- Start button with emergency button (4)
- Deflection pulley with payload hook (5)
- An automatic brake secures the load in any position

Technical data:

- Payload: 500 kg without pulley
1000 kg with pulley
- Lifting height: 12 m without pulley
6 m with pulley
- Mains: 230 V~ 50 Hz
- Power: 1600 watts S3 20 %
- Rope speed: without pulley: 10 m/min
with pulley: 5 m/min.
- Weight: 32.3 kg
- Packing dimensions: 540 x 220 x 310 mm

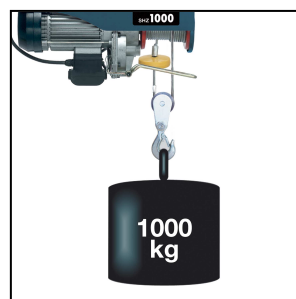
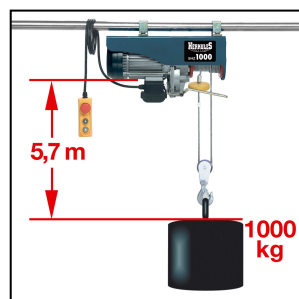
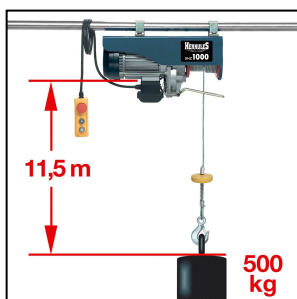
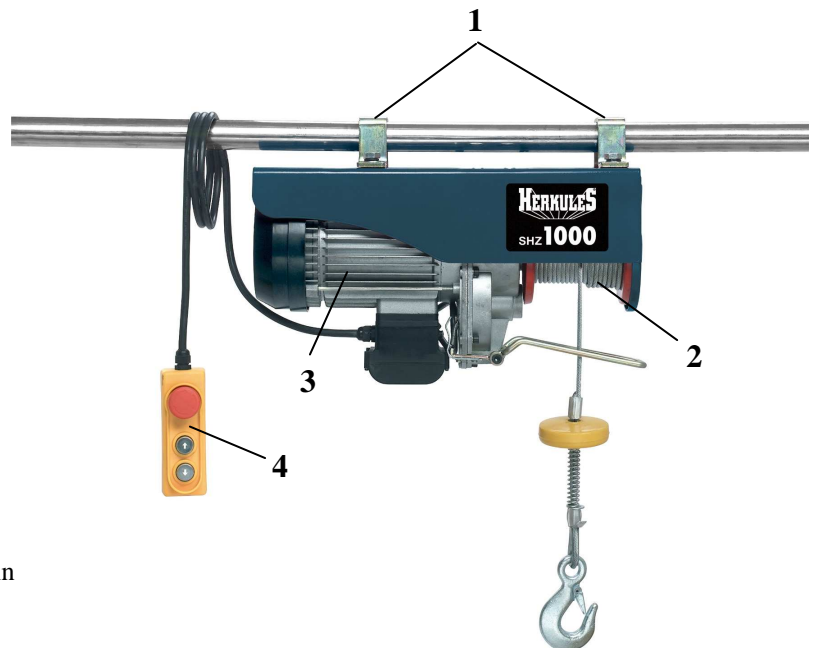

Abbildungen können nicht im Serien-Lieferumfang enthaltenes Zubehör darstellen // Illustrations can contain accessories, which are not included in standard extent of delivery.

Abbildungen ähnlich, produktionsbedingte Abweichung vorbehalten // Illustration similar (in design), production-wise modifications reserved

File: G:\Webshop\T-Produktbeschreibung\60\Originale_Englisch_PA04\2255714_01015.doc

Erstelldatum / create date: 07.04.2005 8:15

Aktualisiert / up dated: 18.04.2005