



SCMS-2125U

GB Original operating instructions
Drag, crosscut and miter saw



Art.-Nr.: 43.008.16



I.-Nr.: 11039

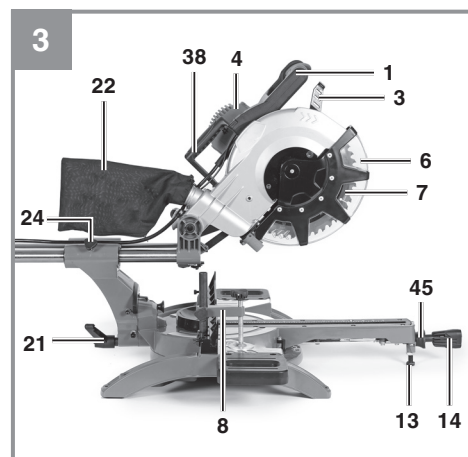
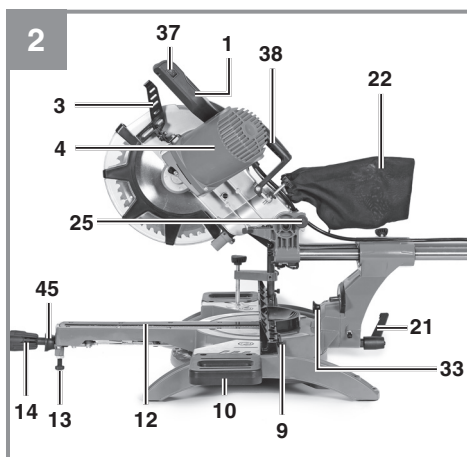
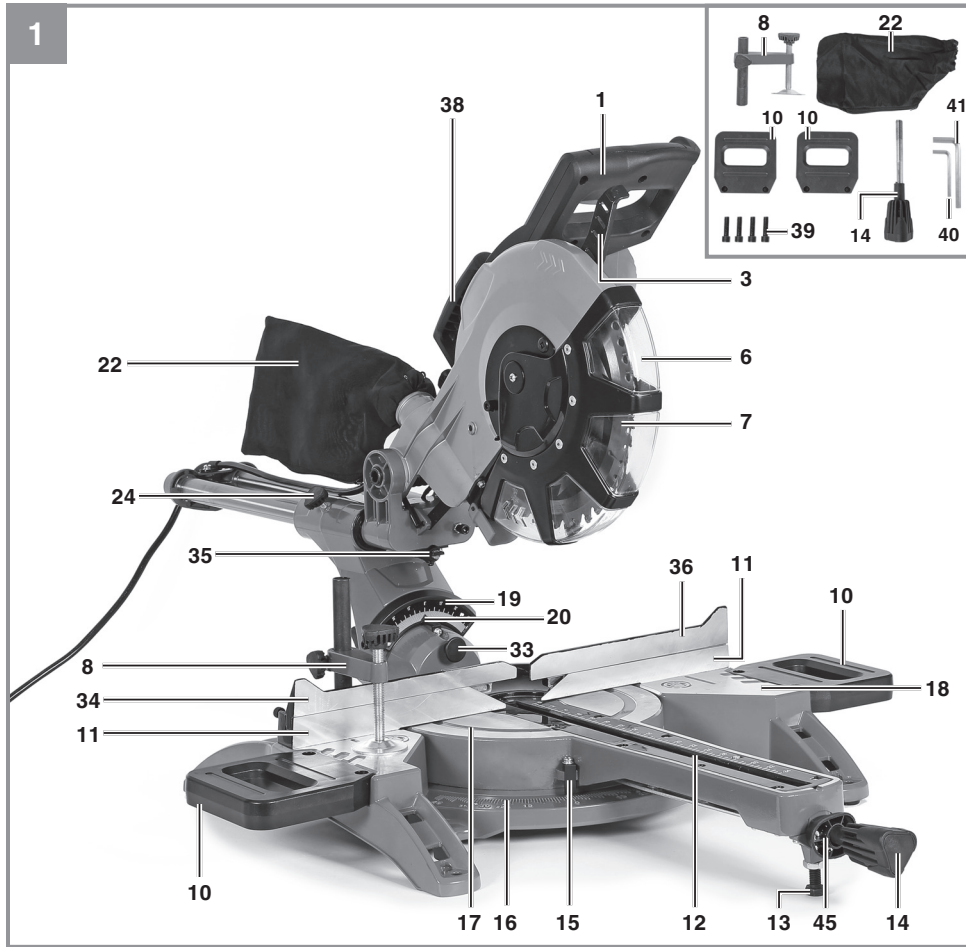

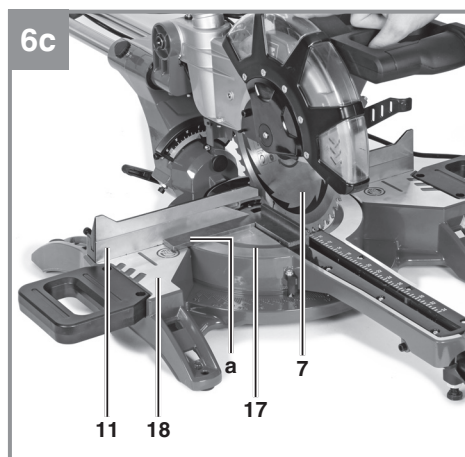
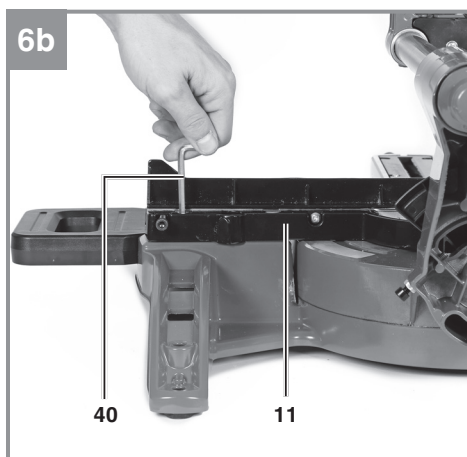
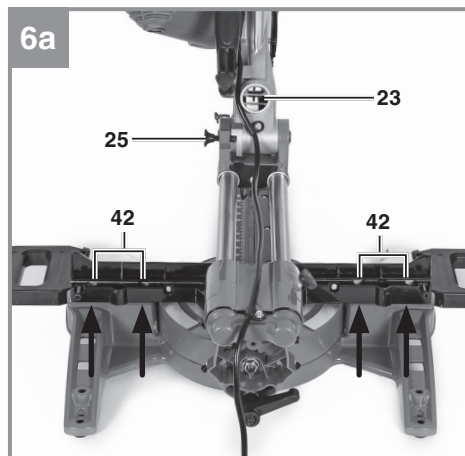
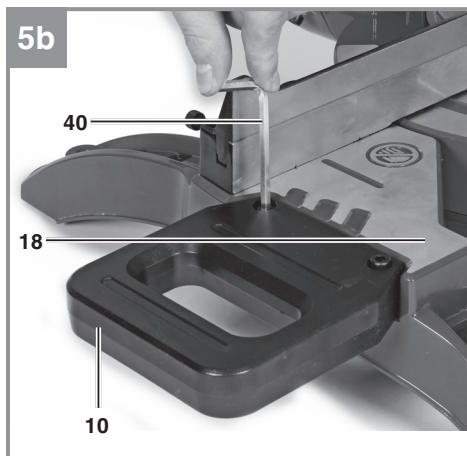
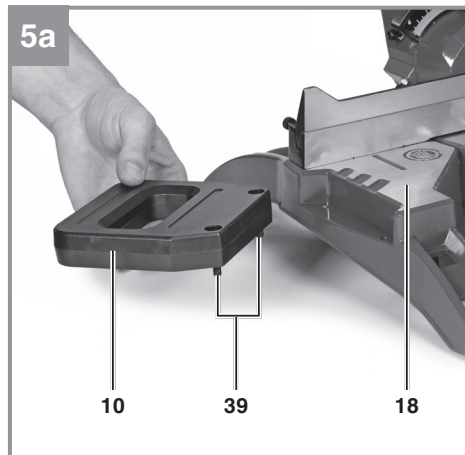
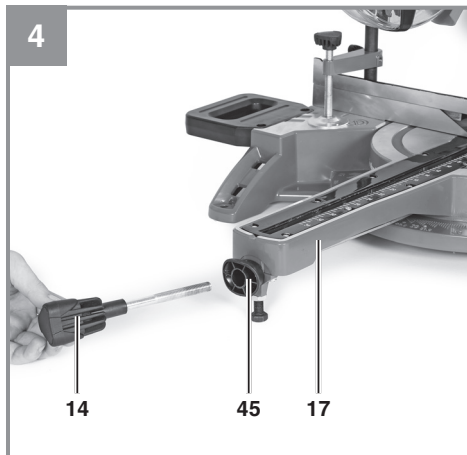

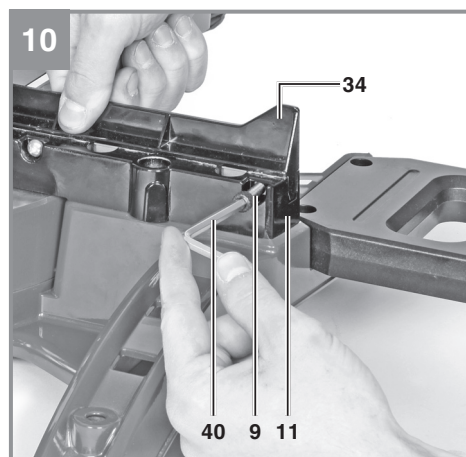
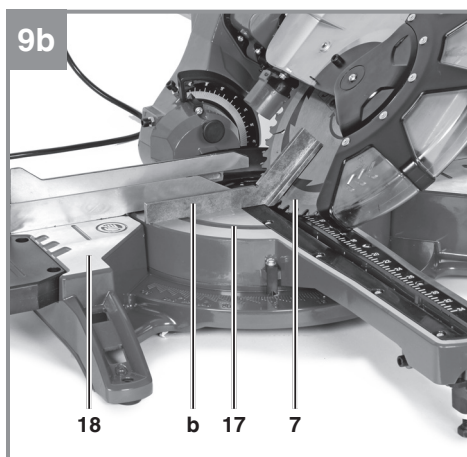
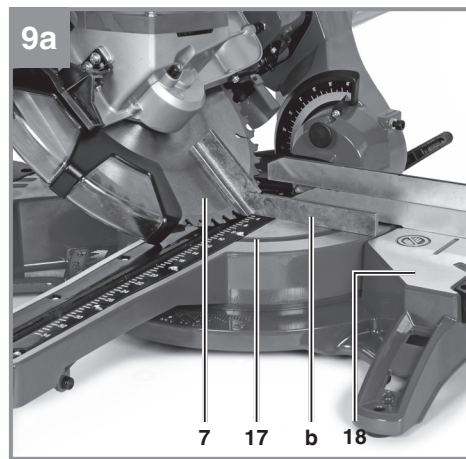
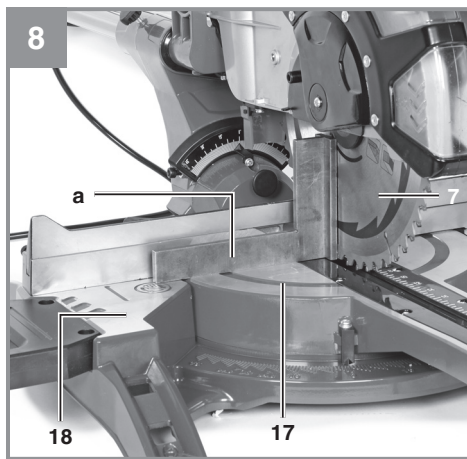
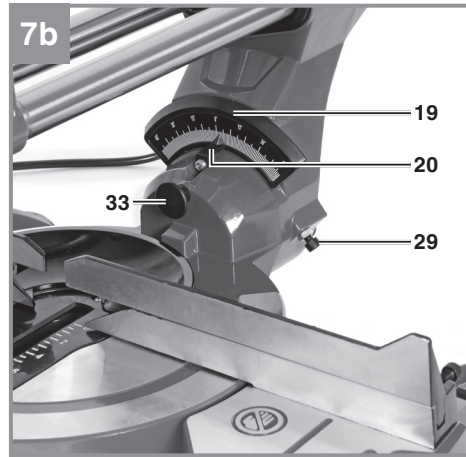
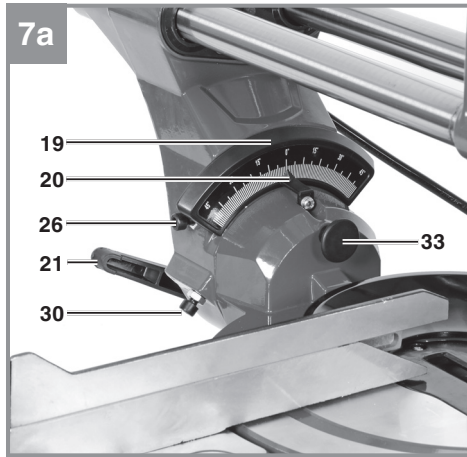

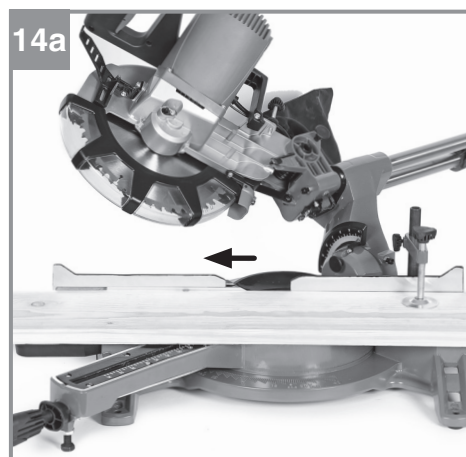
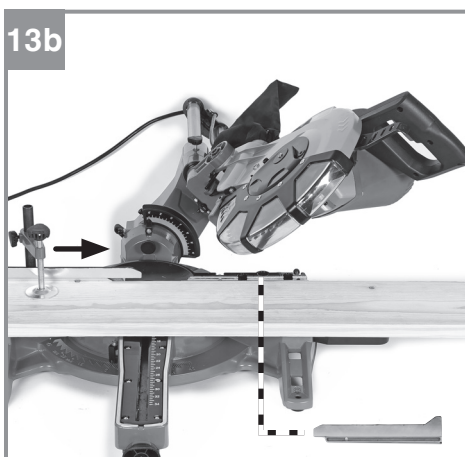
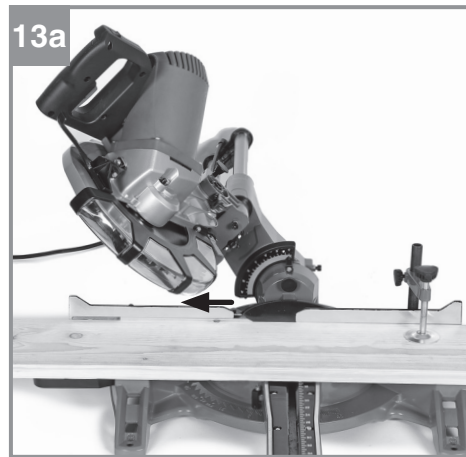
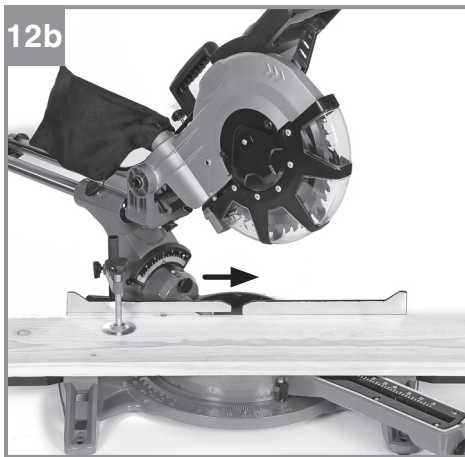
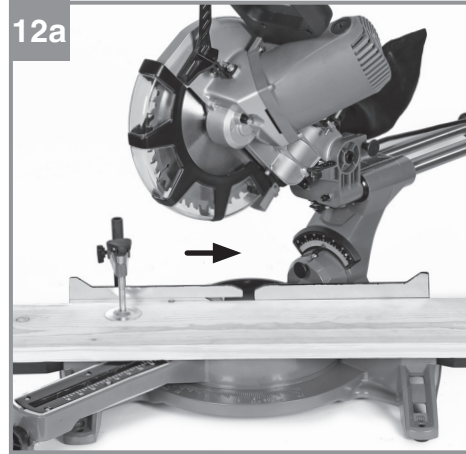
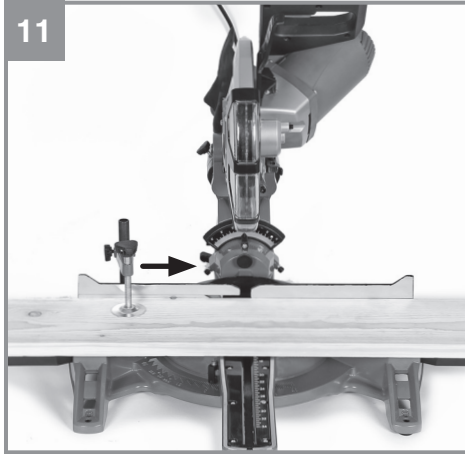

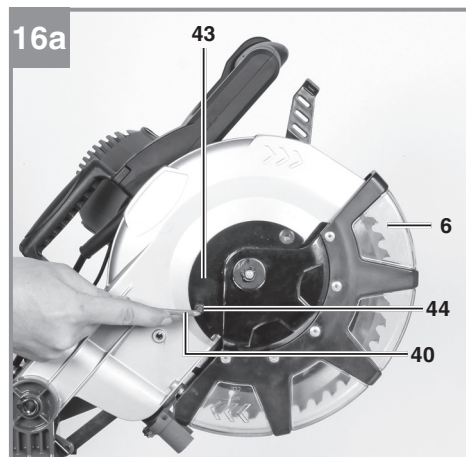
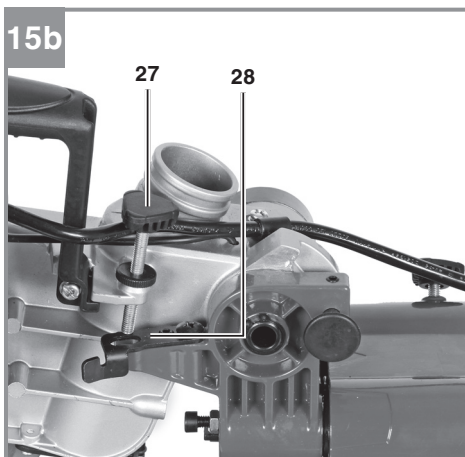
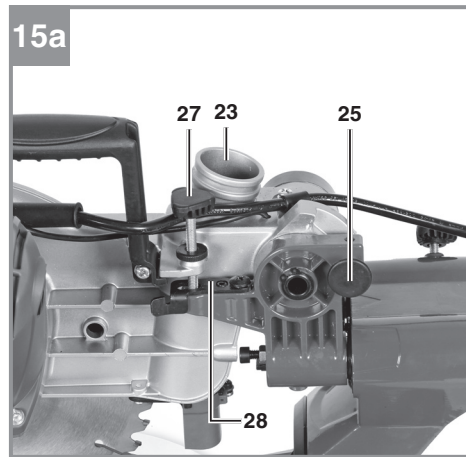
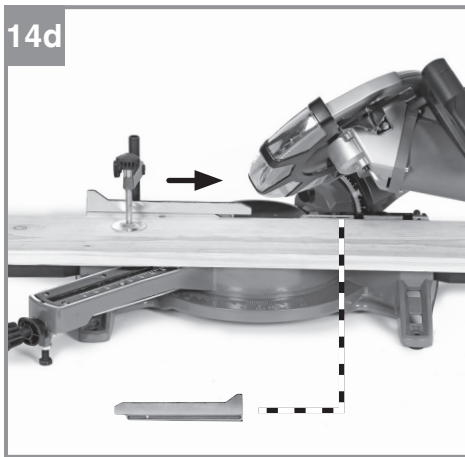
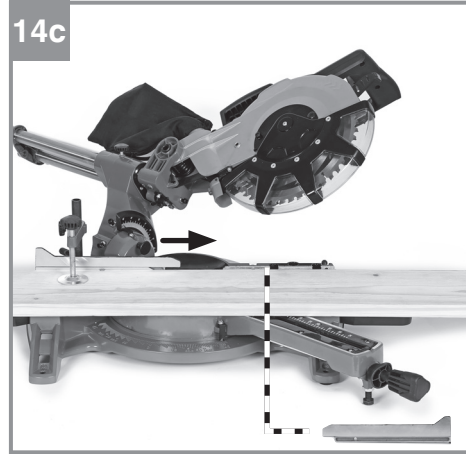
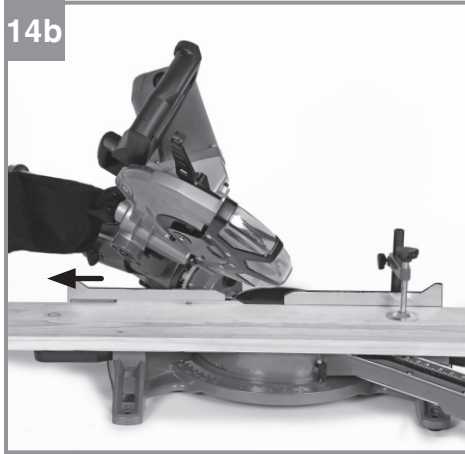

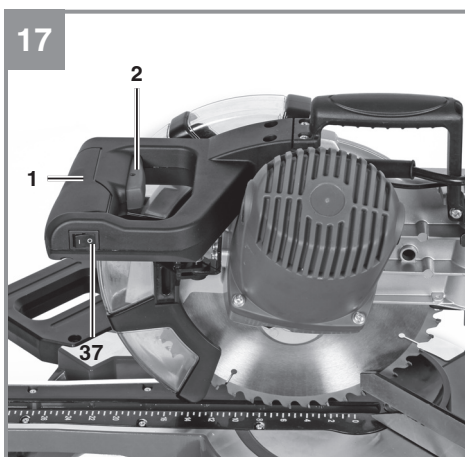
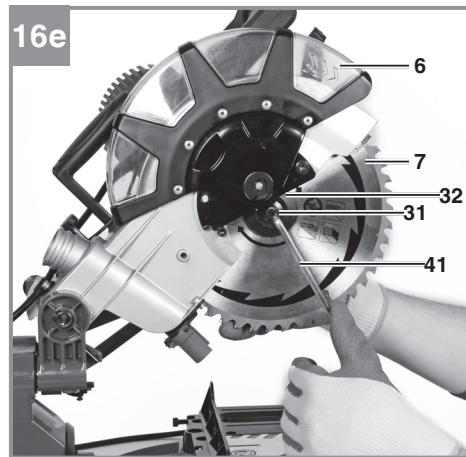
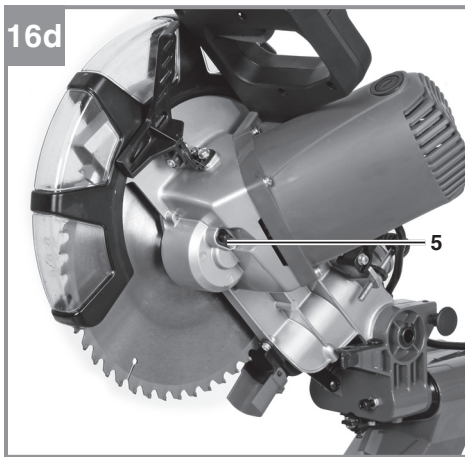
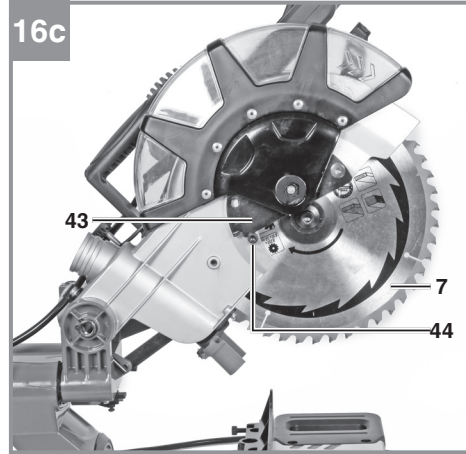
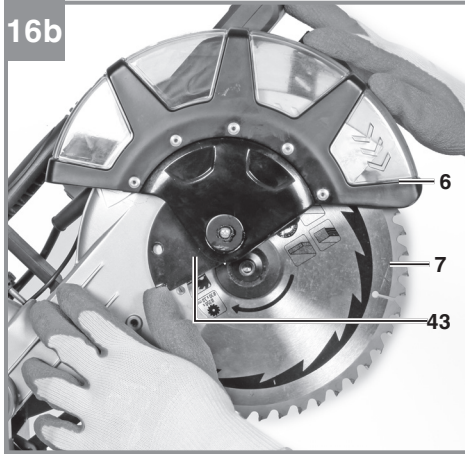



Danger! Read the operating instructions to reduce the risk of injury



Caution! Wear ear-muffs. The impact of noise can cause damage to hearing.



Caution! Wear a breathing mask. Dust which is injurious to health can be generated when working on wood and other materials. Never use the device to work on any materials containing asbestos!



Caution! Wear safety goggles. Sparks generated during working or splinters, chips and dust emitted by the device can cause loss of sight.



Caution! Risk of injury! Do not reach into the running saw blade.

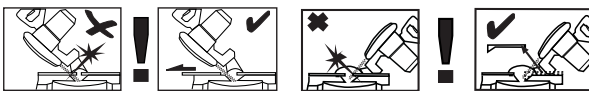

Warning! The adjustable stop rails are secured by hex screws.

To make miter cuts (with the saw head inclined or the turntable set at an angle), the adjustable stop rails must be fixed at an outer position.

For 45° crosscuts to the left, the left stop rail must be pushed outwards and screwed tight.

For 45° crosscuts to the right, the right-hand removable stop rail must be removed in upwards direction.

To make 90° crosscuts, the adjustable stop rail must be fixed at the inner position!

Danger!

When using the equipment, a few safety precautions must be observed to avoid injuries and damage. Please read the complete operating instructions and safety regulations with due care. Keep this manual in a safe place, so that the information is available at all times. If you give the equipment to any other person, hand over these operating instructions and safety regulations as well. We cannot accept any liability for damage or accidents which arise due to a failure to follow these instructions and the safety instructions.

1. Safety regulations**Special information about the laser**

⚠ Caution! Laser radiation
Do not look into the beam
Laser class 2



- Never look directly into the laser path.
- Never direct the laser beam at reflecting surfaces or persons or animals. Even a low output laser beam can inflict injury on the eye.
- Caution: It is vital to follow the work procedures described in these instructions. Using the equipment in any other way may result in hazardous exposure to laser radiation.
- Never open the laser module.
- It is prohibited to carry out any modifications to the laser to increase its power.
- The manufacturer cannot accept any liability for damage due to non-observance of the safety information.

General safety information for power tools**Warning!**

Read all the safety information, instructions, illustrations and technical data provided on or with this power tool. Failure to adhere to the following instructions may result in electric shock, fire and/or serious injury.

Keep all the safety information and instructions in a safe place for future use.

The term „power tool“ used in the safety information and instructions refers to power tools operated from the mains power supply (with a power cable) and to battery operated power tools (without a power cable).

1. Workplace safety

- a) **Keep your work area clean and well lit.** Untidy or unlit work areas can result in accidents.
- b) **Do not use this power tool in an area where there is a risk of explosion and where there are inflammable liquids, gases or dust.** Power tools generate sparks that can ignite dust or vapors.
- c) **Keep children and other people away from the power tool while you are using it.** If you are distracted you may lose control of the power tool.

2. Electrical safety

- a) **The plug on the power tool must fit into the socket. The socket must not be modified in any way. Do not use adapter plugs together with power tools with a protective earth.** Unmodified plugs and matching sockets will reduce the risk of an electric shock.
- b) **Avoid body contact with earthed surfaces such as pipes, heating systems, stoves and refrigerators.** There is an increased risk of suffering an electric shock if your body is earthed.
- c) **Keep the power tool out of the rain and away from moisture.** The ingress of water into an electric power tool increases the risk of an electric shock.
- d) **Do not use the power cable for a purpose for which it is not designed, for example to carry the power tool, hang it up or to pull the plug out of the socket. Keep the power cable away from heat, oil, sharp edges and moving parts.** Power cables that are damaged or tangled increase the risk of an electric shock.

- e) **If you use an electric power tool outdoors, use only extension cables that are suitable for outdoor use.** The use of an extension cable which is suitable for outdoor use reduces the risk of an electric shock.
 - f) **If you cannot avoid using the power tool in a damp location, use a residual current device (RCD) circuit breaker.** The use of a residual current device (RCD) circuit breaker will reduce the risk of suffering an electric shock.
- 3. Safety of persons**
- a) **Be careful, watch what you are doing and be sensible and responsible when using an electric power tool. Never use the power tool if you are tired or under the influence of drugs, alcohol or medication.** One moment of inattention when using the electric tool can result in serious injuries.
 - b) **Wear personal safety equipment and always wear safety goggles.** Wearing personal safety equipment such as dust masks, non-slip safety shoes, a helmet or ear plugs, depending on the type and application of the tool, reduces the risk of injury.
 - c) **Make sure that the tool cannot start up accidentally. Ensure that the power tool is switched off before you connect it to the power supply and/or connect the battery pack, pick it up or carry it.** If you have your finger on the switch while carrying the power tool or if you connect the power tool to the power supply while it is switched on, this may cause accidents.
 - d) **Remove all adjusting tools or wrenches before you switch on the power tool.** Any tool or wrench in a rotating part of the power tool could cause injuries.
 - e) **Avoid abnormal working postures. Make sure you stand squarely and keep your balance at all times.** This will enable you to control the power tool better in unexpected situations.
 - f) **Wear suitable clothes. Never wear loose fitting clothes or jewelry. Keep hair and clothing away from moving parts.** Loose clothing, jewelry or long hair can be caught by moving parts.
 - g) **If dust extraction devices and dust collection devices can be fitted, they must be connected and must be used correctly.** The use of a dust extractor can reduce the dangers posed by dust.
- h) **Do not allow yourself to be lulled into a false sense of security and do not ignore the safety regulations covering electric power tools, even if you are familiar with the power tool after having used it many times.** Carelessness can lead to serious injuries in just a fraction of a second.
- 4. Using and handling the power tool**
- a) **Do not overload your power tool. Use the correct electric tool for the job in hand.** The correct tool will enable you to work better and more safely within the specific performance range.
 - b) **Do not use an electric power tool if the switch is defective.** An electric power tool that cannot be switched on or off is dangerous and must be repaired.
 - c) **Pull the plug out of the socket and/or remove the removable battery pack before making any adjustments to the tool, changing plug-in tool parts or putting the power tool down.** These precautions will prevent the power tool starting accidentally.
 - d) **Keep unused electric tools out of the reach of children. Do not allow people who are not familiar with the power tool or who have not read these instructions to use the power tool.** Electric tools are dangerous if they are used by inexperienced people.
 - e) **Look after power tools and plug-in tools with care. Check that moving parts function correctly and do not jam, and whether any parts are broken or damaged such that they adversely affect the function of the power tool. Have damaged parts repaired before you use the power tool.** Many accidents are caused by poorly maintained electric tools.
 - f) **Keep cutting tools sharp and clean.** Carefully maintained cutting tools with sharp cutting edges will jam less and are easier to control.
 - g) **Use the power tool, plug-in tools, etc. as set out in these instructions. Take account of the conditions in your work area and the job in hand.** Using electric tools for purposes other than the one for which they are designed can result in dangerous situations.

h) **Keep the handles and grip surfaces dry, clean and free from oil and grease.** If the handles and grip surfaces are slippery, it will not be possible to operate and control the power tool safely in unforeseen situations.

5. Service

a) **Have your power tool repaired only by trained personnel using only genuine spare parts.** This will ensure that your power tool remains safe to use.

Special safety information for miter saws

Please note that your equipment may not have all the functions described in this safety information. Read the safety information carefully and observe all the instructions required for your machine.

- a) **Miter saws are designed for cutting wood or wood-type products. They are not intended to be used for cutting ferrous materials such as rods, bars, screws, etc.** Abrasive dust will lead to moving parts such as the bottom guard hood getting blocked. Sparks from cutting will burn the bottom guard hood, the insertion plate and other plastic parts
- b) **If possible, use clamps to secure the workpiece.** If you hold the workpiece with your hand, you must keep your hand at least 100 mm away from each side of the saw blade at all times. Never use this saw for cutting workpieces which are too small, to clamp them or to hold them with your hand. If your hand is too close to the saw blade there is a greater risk of injury from contact with the saw blade.
- c) **The workpiece must immovable and either securely clamped or pressed against the stop and the table.** Do not push the workpiece into the saw blade and never cut it "free-handed". Loose or moving workpieces could be catapulted out at high speed and cause injuries.
- d) **Push the saw through the workpiece.** Do not pull the saw backwards through the workpiece. To make a cut, lift the saw head and pull it over the workpiece without cutting. Then switch on the motor, swing the saw head down and push it through the workpiece. If it is pulled to make a cut there is a danger of the saw blade leaping up on the workpiece and the saw blade unit being hurled with force against the operator.
- e) **Never cross your hand over the intended cutting line, either in front of or behind the saw blade.** Supporting the workpiece "with crossed hands", i.e. holding the workpiece on the right-hand side next to the saw blade with your left hand or vice versa is very dangerous.
- f) **Do not reach behind the stop while the saw blade is rotating.** Never place your hands any closer to the rotating saw blade than the safety distance of 100 mm (this applies to both sides of the saw blade, e.g. when removing wood scraps). You may not necessarily be able to see how close your hands are to the rotating saw blade and you could sustain serious injuries.
- g) **Check the workpiece before cutting.** If the workpiece is bent or warped, clamp it with the side which is curved outward facing towards the stop. Always make sure that there are no gaps along the cutting line between the workpiece, stop and table. Bent and warped workpieces could twist or move position and cause the rotating saw blade to get jammed during cutting. There must be no nails or foreign bodies in the workpiece.
- h) **Do not use the saw before all tools, wood scraps, etc., have been cleared from the table; only the workpiece is allowed to be on the table.** Small scraps, loose pieces of wood and other objects which come into contact with the rotating blade could be catapulted out at high speed.
- i) **Only cut one workpiece at a time.** Stacks of more than one workpiece cannot be clamped or held properly and could cause the blade to jam or slip while sawing.
- j) **Make sure that the miter saw is stood on a level and firm work surface before you start using it.** A level and firm work surface will prevent any danger of the miter saw becoming instable.
- k) **Plan your work.** Whenever you adjust the angle of the saw blade or the miter angle, make sure that adjustable stop is correctly adjusted and supports the workpiece without coming into contact with the blade or the guard hood. With the machine switched off and without the workpiece on the table, perform a simulation of the complete movement of the saw blade in order to check that there are no obstructions and there is no risk of cutting into the stop.

- l) **Where workpieces are wider or longer than the table top, make sure that you provide appropriate support for the workpiece, e.g.** in the form of table extensions or sawing trestles. Workpieces which are longer or wider than the table of the miter saw could tilt if they are not supported securely. If a piece of wood which has been cut off or the workpiece tilts, it could push the bottom guard hood up or be catapulted out by the rotating saw blade out of control.
- m) **Do not use the assistance of another person as a substitute for a table extension or additional support.** Instable support for the workpiece could cause the saw blade to jam. In addition, the workpiece could also move while the cut is being performed and pull you and your helper into the rotating blade.
- n) **The piece which has been cut off must not be pressed against the rotating saw blade.** If space is restricted, e.g. if length stops are used, the piece which has been cut off could get wedged in the blade and then hurled out of control.
- o) **The equipment is not allowed to be used for cutting round material.** Rods or poles have a tendency to roll away during cutting, which could result in the blade "catching" and the workpiece in your hand being drawn into the blade.
- p) **Allow the blade to reach its full before you cut in the workpiece.** This will reduce the risk of the workpiece being catapulted away.
- q) **If the workpiece gets jammed or the blade gets blocked, switch off the miter saw.** Wait until all moving parts have come to a standstill, pull out the power plug and/or take out the rechargeable battery. Then remove the jammed material. If you continue sawing when such a blockage occurs, this could lead to a loss of control or damage to the miter saw.
- r) **Release the switch when the cut has been completed, hold the saw head down and wait until the blade has come to a standstill before you remove the piece which has been cut off.** It is extremely dangerous to reach with your hand into the area anywhere near the blade while it is slowing down.
- s) **Hold the handle very firmly if you want to make an incomplete cut or if you release the switch before the saw head has reached its bottom position.** The braking effect of the saw could cause the saw head to be pulled down with a jerk, leading to a risk of injury.
- Additional safety precautions:**
- **Use saw blades which are designed for the purpose and for the material being cut.**
 - **Use only blades which are recommended by the manufacturer and comply with EN 847-1.**
 - **Use only blades with diameters, hole diameters and tooth pitches which conform with the technical data set out in the original operating instructions.**
 - **Use only blades with rotating speeds shown on the blade which are equal to or higher than the rotating speed shown on the power tool.**
 - **Do not use saw blades that are blunt, bent or damaged.**
 - **Check the direction of rotation whenever you change the saw blade.** There are arrows marked on the machine and saw blade to show the direction of rotation. They must match.
 - **Wear gloves to avoid getting cut when you transport and change the saw blades.** Whenever practicable, saw blades must be carried in a container.
 - **Before use, check that the safety guard for the saw blade is in proper working order.** If it does not close automatically or is damaged, do not use the equipment any more. In this case, contact the manufacturer or an authorized customer service outlet to get it professionally repaired.
 - **If a switch is damaged or defective, arrange for it to be replaced by the manufacturer or an authorized customer service outlet.**
 - **Replace worn or damaged table inserts in the saw table with a replacement part, or arrange for them to be replaced by the manufacturer or an authorized customer service outlet.**
 - **Only allow repairs to the equipment to be carried out by the manufacturer or an authorized customer service outlet using original parts, otherwise the user may suffer an accident.**
 - **Connect a dust extractor to the extractor adapter on the machine.**
 - **Make sure that there is adequate stability by always securing the machine to a**

workbench or a table. Use the holes in the machine's base frame to secure the machine. Bolt the base frame to a workbench or a table.

- **Secure long workpieces against falling off, e.g.** using standard roller stands.
- **The extensions to the workpiece support must be fastened and used at all times while work is in progress**
- **The machine is designed for cutting wood and wood-type materials.** To prevent the saw blade overheating, perform cuts quickly using blades that are properly sharpened.
- **Do not use the saw to cut fire wood.**
- **The clamping device for securing the workpiece must be used at all times.** Do not cut workpieces which are too small to clamp securely with the clamping device.
- **Transport the machine by the carry handles and the machine's base frame only.**
- **If the machine is equipped with a laser, this laser may not be replaced by a different type of laser.** Repairs to the laser are only allowed to be carried out by the manufacturer or an authorized customer service outlet.
- **The saw blade must be stationary whenever you carry out any tidying up or cleaning work.** Do not remove any cutting residues or other parts of workpieces from the cutting zone while the machine is running and the saw unit is not at rest (at the top).
- **If you need to use an extension cable, use one with a minimum cross-section of 1.5 mm² to ensure that the machine is supplied with power.**
- **If you use a cable reel, the complete cable must be pulled off the reel.**
- **Keep children and other people away from the equipment.** When not in use, stow the equipment in a location that is out of reach of children and unauthorized users.
- **Pull out the power plug (or take out the rechargeable battery) and check that the blade does not touch the table or workpiece stop in any cutting position.**
- **Adopt a safe working position for your work to ensure that neither of your hands could come into contact with the saw blade if they suddenly slip.**
- **Always stand to the side of the saw blade when working.**

Caution! Take extra care when making double miter cuts.

- **To rectify faults or remove jammed pieces of wood, always switch off the machine first.** Always pull out the power plug (or take out the rechargeable battery).
- **Be sure to observe the safety information and operating and maintenance instructions issued by the manufacturer, as well as the maximum workpiece dimensions listed in the technical data.**
- **Be sure to observe the accident prevention regulations in force in your area as well as all other generally recognized rules of safety.** If you are inexperienced in the use of the machine, you can seek the advice of a qualified professional or attend courses to become trained in using the machine.

Keep the safety information and original operating instructions in a safe place and pass them on with the machine if you hand the machine on to another person.

2. Layout and items supplied

2.1 Layout (Fig. 1-17)

1. Handle
2. On/Off switch
3. Release lever
4. Machine head
5. Saw shaft lock
6. Adjustable blade guard
7. Saw blade
8. Clamping device
9. Locking screw for stop rail
10. Workpiece support
11. Fixed stop rail
12. Table insert
13. Adjustable foot
14. Locking screw
15. Pointer (turntable)
16. Scale (turntable)
17. Turntable
18. Fixed saw table
19. Scale (miter)
20. Pointer (miter)
21. Locking lever
22. Sawdust bag
23. Discharge opening
24. Locking screw for drag guide
25. Retaining pin
26. Adjustment screw for stop 90°

27. Knurled screw for cutting depth limiter
28. Stop for cutting depth limiter
29. Adjustment screw for stop 45° to the left
30. Adjustment screw for stop 45° to the right
31. Flange bolt
32. Outer flange
33. Button
34. Adjustable stop rail
35. Laser
36. Removable stop rail
37. On/Off switch for laser
38. Transport handle
39. Socket head screw 5mm for workpiece support
40. Hex key 5mm
41. Hex key 6mm
42. Adjustment screw for stop rail
43. Cover plate
44. Screw for cover
45. Knob for adjusting the turntable

2.2 Items supplied

Please check that the article is complete as specified in the scope of delivery. If parts are missing, please contact our service center or the sales outlet where you made your purchase at the latest within 5 working days after purchasing the product and upon presentation of a valid bill of purchase. Also, refer to the warranty table in the service information at the end of the operating instructions.

- Open the packaging and take out the equipment with care.
- Remove the packaging material and any packaging and/or transportation braces (if available).
- Check to see if all items are supplied.
- Inspect the equipment and accessories for transport damage.
- If possible, please keep the packaging until the end of the guarantee period.

Danger!

The equipment and packaging material are not toys. Do not let children play with plastic bags, foils or small parts. There is a danger of swallowing or suffocating!

- Drag, crosscut and miter saw
- Clamping device
- Workpiece support (2x)
- Locking screw
- Sawdust bag
- Socket head screw 5mm for workpiece support (4x)

- Hex key 5mm
- Hex key 6mm
- Original operating instructions
- Safety instructions

3. Proper use

The drag, crosscut and miter saw is designed for cross-cutting wood and wood-type materials which are appropriate for the machine's size. The saw is not designed for cutting firewood.

The equipment is to be used only for its prescribed purpose. Any other use is deemed to be a case of misuse. The user / operator and not the manufacturer will be liable for any damage or injuries of any kind caused as a result of this.

Please note that our equipment has not been designed for use in commercial, trade or industrial applications. Our warranty will be voided if the machine is used in commercial, trade or industrial businesses or for equivalent purposes.

The equipment is to be operated only with suitable saw blades. It is prohibited to use any type of cutting-off wheel.

To use the equipment properly you must also observe the safety information, the assembly instructions and the operating instructions to be found in this manual.

All persons who use and service the equipment have to be acquainted with these operating instructions and must be informed about the equipment's potential hazards. It is also imperative to observe the accident prevention regulations in force in your area. The same applies for the general rules of health and safety at work.

The manufacturer will not be liable for any changes made to the equipment nor for any damage resulting from such changes. Even when the equipment is used as prescribed it is still impossible to eliminate certain residual risk factors. The following hazards may arise in connection with the machine's construction and design:

- Contact with the saw blade in the uncovered saw zone.
- Reaching into the running saw blade (cut injuries).
- Kick-back of workpieces and parts of workpieces.
- Saw blade fracturing.

- Catapulting of faulty carbide tips from the saw blade.
- Damage to hearing if ear-muffs are not used as necessary.
- Harmful emissions of wood dust when used in closed rooms.

4. Technical data

AC motor:230-240 V ~ 50Hz
 Power: 2100 W S1 / 2350 W S6 25%
 Idle speed n_0 :4000 min⁻¹
 Carbide saw blade: \varnothing 250 x \varnothing 30 x 3.0 mm
 Maximum tooth pitch: 3.2 mm
 Number of teeth: 48
 Swiveling range: -47° / 0° / +47°
 Miter cut to the left:0° to 45°
 Miter cut to the right:0° to 45°
 Saw width at 90°:340 x 75 mm
 Saw width at 45°:240 x 75 mm
 Saw width at 2 x 45°
 (double miter cut left):240 x 42 mm
 Saw width at 2 x 45°
 (double miter cut right):240 x 25 mm
 Weight: approx. 16 kg
 Laser class: 2
 Wavelength of laser: 650 nm
 Laser output: \leq 1 mW
 Protection class: II/□

Minimum workpiece size: Only ever cut workpieces which are big enough to clamp securely with the clamping device – minimum length 180 mm.

Operating mode S6 25%: Continuous operation with idling (cycle time 10 minutes). To ensure that the motor does not become excessively hot, it may only be operated for 25% of the cycle at the specified rating and must then be allowed to idle for 75% of the cycle.

Danger! **Noise**

The noise emission values were measured in accordance with EN 62841.

Operation

L_{pA} sound pressure level 96 dB(A)
 K_{pA} uncertainty 3 dB(A)
 L_{WA} sound power level 109 dB(A)
 K_{WA} uncertainty 3 dB(A)

Wear ear-muffs.

The impact of noise can cause damage to hearing.

The stated noise emission values were measured in accordance with a set of standardized criteria and can be used to compare one power tool with another.

The stated noise emission values can also be used to make an initial assessment of exposure.

Warning:

The noise emission levels may vary from the level specified during actual use, depending on the way in which the power tool is used, especially the type of workpiece it is used for.

Keep the noise emissions and vibrations to a minimum.

- Only use appliances which are in perfect working order.
- Service and clean the appliance regularly.
- Adapt your working style to suit the appliance.
- Do not overload the appliance.
- Have the appliance serviced whenever necessary.
- Switch the appliance off when it is not in use.

Caution!

Residual risks

Even if you use this electric power tool in accordance with instructions, certain residual risks cannot be ruled out. The following hazards may arise in connection with the equipment's construction and layout:

1. Lung damage if no suitable protective dust mask is used.
2. Damage to hearing if no suitable ear protection is used.
3. Health damage caused by hand-arm vibrations if the equipment is used over a prolonged period or is not properly guided and maintained.

5. Before starting the equipment

Before you connect the equipment to the mains supply make sure that the data on the rating plate are identical to the mains data.

Warning!

Always pull the power plug before making adjustments to the equipment.

5.1 General information

- The equipment must be set up where it can stand securely, i.e. it should be bolted to a workbench, a universal base frame or similar.
- All covers and safety devices have to be properly fitted before the equipment is switched on.
- It must be possible for the blade to run freely.
- When working with wood that has been processed before, watch out for foreign bodies such as nails or screws, etc.
- Before you actuate the On/Off switch, make sure that the saw blade is correctly fitted and that the equipment's moving parts run smoothly.

5.2 Assembling the saw (Fig. 1-5)

- Fit to the locking screw (14) to the turntable (17).
- Fit the workpiece supports (10) on the left and on the right of the fixed saw table (18). Do this with the socket head screws (39) and the 5mm hex key (40).
- To fit the sawdust bag (22) to the discharge opening (23) on the crosscut saw, spread the metal ring apart on the opening. When the metal ring is back in its original shape, the sawdust bag is held securely in position.
- The clamping device (8) can be fitted on the left or right of the fixed saw table (18).

5.3 Adjusting the saw (Fig. 1-3)

- To adjust the turntable (17), loosen the locking screw (14) by approx. 2 turns, which frees the turntable (17).
- Pull on the knob (45) to release the turntable (17) from a locked position. Keep holding the knob (45) pulled out until the turntable (17) is at the required angular setting.
- Turn the turntable (17) and scale pointer (15) to the desired angular setting on the dial (16) and lock into place with the locking screw (14). The saw has locking positions at angles of - 45°, -31.6°, -22.5°, -15°, 0°, 15°, 22.5°, 31.6° and 45°, at which the turntable (17) au-

dibly clicks into position.

- To release the saw from its position at the bottom, pull the retaining pin (25) out of the motor mounting while pressing down lightly on the machine head (4).
- Swing the machine head (4) up until the release lever (3) latches into place.
- To adjust the machine head (4) for a miter cut, slacken the locking lever (21).
- Then you can tilt the machine head (4) to the left by up to 45°. After the desired angular setting has been set on the scale pointer (20) on the scale (19), secure the machine head (4) again with the locking lever (21).
- To tilt the machine head to the right by up to 45°, proceed as follows:
 - Tilt the machine head (4) by approx. 10° to the left.
 - Pull out and hold the button (33).
 - Swing the machine head (4) over the 0° line to the right.
 - After reaching approx. 10° on the right-hand side, let go of the button (33).
 - When the pointer (20) reaches the desired angular setting on the scale (19), secure the machine head (4) again with the locking lever (21).
- To return the machine head to 0° on the scale (19) there is no need to press the button (33) again.
- To ensure that the saw is standing securely, adjust the adjustable foot (13) by turning it so that the saw stands in a horizontal and firm position.

5.4 Precision adjustment of the stop rail (Fig. 6)

- Lower the machine head (4) and fasten in place with the retaining pin (25).
- Fasten the turntable (17) in 0° position.
- Place the 90° stop angle (a) between the blade (7) and the stop rail (11).
- Slacken the four adjustment screws (42) using the 5mm hex key (40), set the stop rail (11) to 90° in relation to the saw blade (7) and retighten the adjustment screws (42).
- There is no angle stop (a) included the scope of this delivery.

5.5 Precision adjustment of the stop for crosscut 90° (Fig. 7a, 8)

- Fasten the turntable (17) in 0° position.
- Slacken the locking lever (21) and tilt the machine head (4) to 0° using the handle (1).
- Place the 90° angular stop (a) between the

- blade (7) and the turntable (17).
- Adjust the adjustment screw (26) until the angle between the blade (7) and the turntable (17) equals 90°.
- Finally, check the position of the pointer (20) on the scale (19).
- If necessary, release the pointer (20) with a crosstip screwdriver, move to the 0° position of the scale (19) and retighten the holding screw.
- The angle stop (a) and crosstip screwdriver are not included in the scope of this delivery.

5.6 Precision adjustment of the stop for miter cut 45° (Fig. 7, 9)

- Lower the machine head (4) and fasten in place with the retaining pin (25).
- Fasten the turntable (17) in 0° position.
- Undo the locking lever (21) and move the machine head (4) all the way to the left using the handle (1), until it coincides at 45°.
- Place the 45° stop angle (b) between the blade (7) and the turntable (17).
- Adjust the adjustment screw (29) so that the angle between the blade (7) and the turntable (17) equals exactly 45°.
- To set the stop 45° on the right-hand side: Tilt the machine head (4) to the right (see section 5.3) and set the adjustment screw (30) according to the left-hand side.
- No angle stop (b) included.

6. Operation

Warning! To make 90° crosscuts, the adjustable stop rail (34) must be fixed at the inner position:

- Undo the locking screw (9) of the adjustable stop rail and push the adjustable stop rail inwards.
- The adjustable stop rail (34) must be fixed far enough in front of the innermost position that the distance between the stop rail (34) and the saw blade (7) amounts to a maximum of 8 mm.
- Before making a cut, check that the stop rail and the saw blade cannot collide.
- Tighten the locking screw (9) again.

Warning! To make 0°-45° miter cuts to the left (with the machine head (4) inclined or with the turntable set at an angle), the adjustable stop rail (34) must be fixed at an outer position.

- Undo the locking screw (9) of the adjustable

stop rail and push the adjustable stop rail outwards.

- The adjustable stop rail (34) must be fixed far enough in front of the innermost position that the distance between the stop rail (34) and the saw blade (7) amounts to a maximum of 8 mm.
- Before making a cut, check that the stop rail and the saw blade cannot collide.
- Tighten the locking screw (9) again.

Warning! This saw is equipped with a removable stop rail (36) which is screwed to the right-hand side of the fixed stop rail (11).

To make 0°-45° miter cuts to the right (with the machine head (4) inclined or with the turntable set at an angle), the removable stop rail (36) must be completely removed. **Warning!** In this case the maximum permissible workpiece height is reduced (see 4. Technical data).

- Open the locking screw (9) of the removable stop rail (36) far enough for you to be able to remove the stop rail (36) in upwards direction.
- Always fasten the removable stop rail (36) on the equipment again after you have completed your work.
- The stop rail must always be kept together with the equipment. A removed stop rail will impair the operational safety of the equipment.

6.1 Cross cut 90° and turntable 0° (Fig. 1-3, 11)

For cutting widths up to approx. 100 mm it is possible to fix the saw's drag function with the locking screw for drag guide (24) in rear position. If the cutting width exceeds 100 mm you must ensure that the locking screw for drag guide (24) is slackened and that the machine head (4) can be moved.

- Move the machine head (4) to its upper position.
- Use the handle (1) to push back the machine head (4) and fix it in this position if required (dependent on the cutting width).
- Place the piece of wood to be cut at the stop rail (11) and on the turntable (17).
- Lock the material with the clamping device (8) on the fixed saw table (18) to prevent the material from moving during the cutting operation.
- Push down the release lever (3) to release the machine head (4).
- Press the On/Off switch (2) to start the motor.
- With the drag guide fixed in place: Use the

handle (1) to move the machine head (4) steadily and with light pressure downwards until the saw blade (7) has completely cut through the workpiece.

- With the drag guide not fixed in place: Pull the machine head (4) all the way to the front and then use the handle (1) to move it downwards steadily and with light pressure. Now push the machine head (4) slowly and steadily to the very back until the saw blade (7) has completely cut through the workpiece.
- When the cutting operation is completed, move the machine head (4) back to its upper (home) position and release the On/Off button (2).

Important! The integral resetting springs will automatically lift the machine head. Do not simply let go of the handle (1) after cutting, but allow the machine head (4) to rise slowly, applying slight counter pressure as it does so.

6.2 Cross cut 90° and turntable 0° - 45° (Fig. 1-3, 12)

The crosscut saw can be used to make crosscuts of 0°- 45° to the left and 0° - 45° to the right in relation to the stop rail.

- Release the turntable (17) by undoing the locking screw (14).
- Turn the turntable (17) and scale pointer (15) to the desired angular setting on the dial (16) and lock into place with the locking screw (14). The saw has locking positions at angles of - 45°, -31.6°, -22.5°, -15°, 0°, 15°, 22.5°, 31.6° and 45°, at which the turntable (17) audibly clicks into position.
- Retighten the locking screw (14) to secure the turntable (17) in place.
- Cut as described in section 6.1.

6.3 Miter cut 0°- 45° and turntable 0° (Fig. 1-3, 13)

The crosscut saw can be used to make miter cuts to the left of 0°-45° and to the right of 0°-45° in relation to the work surface.

- If required, dismantle the clamping device (8) or mount it on the opposite side of the fixed saw table (18).
- Move the machine head (4) to its upper position.
- Fasten the turntable (17) in 0° position.
- Adjust the miter angle on the machine head as described in section 5.3.
- Cut as described in section 6.1.

6.4 Miter cut 0°- 45° and turntable 0°- 45° (Fig. 1-3, 14)

The crosscut saw can be used to make miter cuts to the left of 0°-45° and to the right of 0°-45° in relation to the work surface, with simultaneous setting of the turntable from 0°-45° to the left or 0°-45° to the right in relation to the stop rail (double miter cut).

- If required, dismantle the clamping device (8) or mount it on the opposite side of the fixed saw table (18).
- Move the machine head (4) to its upper position.
- Release the turntable (17) by undoing the locking screw (14).
- Use the handle (1) to adjust the turntable (17) to the angle required (in this connection see also section 6.2).
- Retighten the locking screw (14) to secure the turntable in place.
- Adjust the miter angle on the machine head as described in section 5.3.
- Cut as described in section 6.1.

6.5 Limiting the cutting depth (Fig. 15)

- If the stop (28) is aligned parallel to the saw blade (4), the cutting depth limiter will be deactivated.
- To activate the cutting depth limiter, the stop (28) must be swung to the right.
- The cutting depth can be infinitely adjusted using the screw (27). Turn the screw (27) in or out to set the required cutting depth and then retighten the knurled nut on the screw (27).
- Check the setting by completing a test cut.

6.6 Sawdust bag (Fig. 2)

The saw is equipped with a sawdust bag (22) for sawdust and chips.

The sawdust bag (22) can be emptied by means of a zipper at the bottom.

6.7 Replacing the saw blade (Fig. 1, 16)

- **Warning!** Before changing the saw blade: Pull out the power plug!
- **Caution!** Wear work gloves to prevent injury when changing the saw blade.
- Swing the machine head upwards (4).
- Undo the screw (44) on the cover plate (43) of the saw blade.
- Pull back the adjustable blade guard (6) and at the same time turn the cover plate to achieve access to the flange bolt.
- Push up the cover plate (43) far enough for you to be able to screw in the screw (44)

again by approx. 5 turns. The flange bolt (31) is now accessible for changing the saw blade.

- Press the saw shaft lock (5) with one hand while positioning the hexagon key 6mm (41) on the flange bolt (31) with the other hand. The saw shaft lock (5) engages after no more than one rotation.
- Now, using a little more force, slacken the flange screw (31) in the clockwise direction.
- Turn the flange screw (31) right out and remove the external flange (32).
- Take the blade (7) off the inner flange and pull out downwards.
- Carefully clean the flange screw (31), outer flange (32) and inner flange.
- Fit and fasten the new saw blade (7) in reverse order.
- **Caution!** The cutting angle of the teeth, in other words the direction of rotation of the saw blade (7) must coincide with the direction of the arrow on the housing.
- Finally, the screw (44) and the cover plate (43) must be screwed tight again in bottom position.
- **Warning!** Check that the safety devices are in good working condition before you fit the power plug again.
- **Warning!** Every time that you change the saw blade, check that the saw blade guard (6) opens and closes again in accordance with requirements. Also check that the saw blade (7) spins freely in the saw blade guard (6).
- **Warning!** Every time that you change the saw blade, check to see that it spins freely in the table insert (12) in both perpendicular and 45° angle settings.
- **Warning!** You should replace the table insert (12) immediately whenever it is worn or damaged. To do so, undo the Philips screws in the table insert (12) and take the table insert out of the fixed saw table (18). To fit the new table insert (12), proceed in reverse order.
- **Warning!** The work to change and align the saw blade (7) must be carried out correctly.

6.8 Transport (Fig. 1-3)

- Retighten the locking screw (14) to secure the turntable (17) in place.
- Activate the release lever (3), press the machine head (4) downwards and secure with the safety pin (25). The saw is now locked in its bottom position.
- Fix the saw's drag function with the locking screw for drag guide (24) in rear position.

- Carry the equipment by the fixed saw table (18).
- To set up the equipment again, proceed as described in section 5.2, 5.3.

6.9 Operating the laser (Fig. 1, 17)

Switching on: Move the On/Off switch (37) to the "I" position to switch on the laser (35). A laser line is projected onto the material you wish to process, providing an exact guide for the cut.

Switching off: Move the On/Off switch (37) to the "O" position.

6.10 Electric brake

For safety reasons, the equipment is supplied with an electric brake system for the saw blade. The equipment may therefore emit an odor or generate sparks when it is switched off. This has no influence on the operational performance or safety of the equipment.

7. Replacing the power cable

Danger!

If the power cable for this equipment is damaged, it must be replaced by the manufacturer or its after-sales service or similarly trained personnel to avoid danger.

8. Cleaning, maintenance and ordering of spare parts

Danger!

Always pull out the mains power plug before starting any cleaning work.

8.1 Cleaning

- Keep all safety devices, air vents and the motor housing free of dirt and dust as far as possible. Wipe the equipment with a clean cloth or blow it with compressed air at low pressure.
- We recommend that you clean the device immediately each time you have finished using it.
- Clean the equipment regularly with a moist cloth and some soft soap. Do not use cleaning agents or solvents; these could attack the plastic parts of the equipment. Ensure that no water can seep into the device. The ingress of water into an electric tool increases the risk of an electric shock.

8.2 Carbon brushes

In case of excessive sparking, have the carbon brushes checked only by a qualified electrician. Important! The carbon brushes should not be replaced by anyone but a qualified electrician.

8.3 Maintenance

There are no parts inside the equipment which require additional maintenance.

8.4 Ordering spare parts and accessories

Please provide the following information when ordering spare parts:

- Type of unit
- Article number of the unit
- ID number of the unit
- Spare part number of the required spare part

For our latest prices and information please go to www.isc-gmbh.info



Tip! For good results we recommend high-quality accessories from **kwb** !
www.kwb.eu
welcme@kwb.eu

9. Disposal and recycling

The equipment is supplied in packaging to prevent it from being damaged in transit. The raw materials in this packaging can be reused or recycled. The equipment and its accessories are made of various types of material, such as metal and plastic. Never place defective equipment in your household refuse. The equipment should be taken to a suitable collection center for proper disposal. If you do not know the whereabouts of such a collection point, you should ask in your local council offices.

10. Storage

Store the equipment and accessories out of children's reach in a dark and dry place at above freezing temperature. The ideal storage temperature is between 5 and 30 °C. Store the electric tool in its original packaging.



For EU countries only

Never place any electric power tools in your household refuse.

To comply with European Directive 2012/19/EC concerning old electric and electronic equipment and its implementation in national laws, old electric power tools have to be separated from other waste and disposed of in an environment-friendly fashion, e.g. by taking to a recycling depot.

Recycling alternative to the return request:

As an alternative to returning the equipment to the manufacturer, the owner of the electrical equipment must make sure that the equipment is properly disposed of if he no longer wants to keep the equipment. The old equipment can be returned to a suitable collection point that will dispose of the equipment in accordance with the national recycling and waste disposal regulations. This does not apply to any accessories or aids without electrical components supplied with the old equipment.

The reprinting or reproduction by any other means, in whole or in part, of documentation and papers accompanying products is permitted only with the express consent of the iSC GmbH.

Subject to technical changes

Service information

We have competent service partners in all countries named on the guarantee certificate whose contact details can also be found on the guarantee certificate. These partners will help you with all service requests such as repairs, spare and wearing part orders or the purchase of consumables.

Please note that the following parts of this product are subject to normal or natural wear and that the following parts are therefore also required for use as consumables.

Category	Example
Wear parts*	Carbon brushes
Consumables*	Saw blade
Missing parts	

* Not necessarily included in the scope of delivery!

In the event of defects or faults, please register the problem on the internet at www.isc-gmbh.info. Please ensure that you provide a precise description of the problem and answer the following questions in all cases:

- Did the equipment work at all or was it defective from the beginning?
- Did you notice anything (symptom or defect) prior to the failure?
- What malfunction does the equipment have in your opinion (main symptom)?
Describe this malfunction.

Warranty certificate

Dear Customer,

All of our products undergo strict quality checks to ensure that they reach you in perfect condition. In the unlikely event that your device develops a fault, please contact our service department at the address shown on this guarantee card. You can also contact us by telephone using the service number shown. Please note the following terms under which guarantee claims can be made:

1. These guarantee terms apply to consumers only, i.e. natural persons intending to use this product neither for their commercial activities nor for any other self-employed activities. These warranty terms regulate additional warranty services, which the manufacturer mentioned below promises to buyers of its new products in addition to their statutory rights of guarantee. Your statutory guarantee claims are not affected by this guarantee. Our guarantee is free of charge to you.
2. The warranty services cover only defects due to material or manufacturing faults on a product which you have bought from the manufacturer mentioned below and are limited to either the rectification of said defects on the product or the replacement of the product, whichever we prefer.
Please note that our devices are not designed for use in commercial, trade or professional applications. A guarantee contract will not be created if the device has been used by commercial, trade or industrial business or has been exposed to similar stresses during the guarantee period.
3. The following are not covered by our guarantee:
 - Damage to the device caused by a failure to follow the assembly instructions or due to incorrect installation, a failure to follow the operating instructions (for example connecting it to an incorrect mains voltage or current type) or a failure to follow the maintenance and safety instructions or by exposing the device to abnormal environmental conditions or by lack of care and maintenance.
 - Damage to the device caused by abuse or incorrect use (for example overloading the device or the use of unapproved tools or accessories), ingress of foreign bodies into the device (such as sand, stones or dust, transport damage), the use of force or damage caused by external forces (for example by dropping it).
 - Damage to the device or parts of the device caused by normal or natural wear or tear or by normal use of the device.
4. The guarantee is valid for a period of 3 years starting from the purchase date of the device. Guarantee claims should be submitted before the end of the guarantee period within two weeks of the defect being noticed. No guarantee claims will be accepted after the end of the guarantee period. The original guarantee period remains applicable to the device even if repairs are carried out or parts are replaced. In such cases, the work performed or parts fitted will not result in an extension of the guarantee period, and no new guarantee will become active for the work performed or parts fitted. This also applies if an on-site service is used.
5. To make a claim under the guarantee, please register the defective device at: www.isc-gmbh.info. Please keep your bill of purchase or other proof of purchase for the new device. Devices that are returned without proof of purchase or without a rating plate shall not be covered by the guarantee, because appropriate identification will not be possible. If the defect is covered by our guarantee, then the item in question will either be repaired immediately and returned to you or we will send you a new replacement.

Of course, we are also happy offer a chargeable repair service for any defects which are not covered by the scope of this guarantee or for units which are no longer covered. To take advantage of this service, please send the device to our service address.

Also refer to the restrictions of this warranty concerning wear parts, consumables and missing parts as set out in the service information in these operating instructions.

- D** erkl rt folgende Konformit t gem B EU-Richtlinie und Normen f r Artikel
- GB** explains the following conformity according to EU directives and norms for the following product
- F** d clare la conformit  suivante selon la directive CE et les normes concernant l'article
- I** dichiara la seguente conformit  secondo la direttiva UE e le norme per l'articolo
- NL** verklaart de volgende overeenstemming conform EU richtlijn en normen voor het product
- E** declara la siguiente conformidad a tenor de la directiva y normas de la UE para el art culo
- P** declara a seguinte conformidade, de acordo com as diretiva CE e normas para o artigo
- DK** attesterer f lgende overensstemmelse i medf r af EU-direktiv samt standarder for artikel
- S** f rklarar f ljande  verensst mmelse enl. EU-direktiv och standarder f r artikeln
- FIN** vakuuttaa, ett  tuote t ytt t  EU-direktiivin ja standardien vaatimukset
- EE** t endab toote vastavust EL direktiivile ja standarditele
- CZ** vyd v  n sleduj c  prohl sen  o shod  podle sm rnice EU a norem pro v robek
- SLO** potrjuje slede o skladnost s smernico EU in standardi za izdelek
- SK** vyd v  n sleduj ce prehl senie o zhode podl'a smernice EU a noriem pre v robok
- H** a cikkekhez az EU-ir nyvonal  s Norm k szerint a k vetkez  konformit st jelenti ki
- PL** deklaruje zgodno c wymienionego poniżej artykułu z nast puj cymi normami na podstawie dyrektywy WE.
- BG** декларира съответното съответствие съгласно Директива на ЕС и норми за артикул
- LV** paskaidro š du atbilst bu ES direkt vai un standartiem
- LT** apib dina š j atitikim  EU reikalavimams ir prek s normoms
- RO** declar  urm toarea conformitate conform directivei UE și normelor pentru articolul
- GR** δηλώνει την ακόλουθη συμμόρφωση σύμφωνα με την Οδηγία ΕΚ και τα πρότυπα για το προϊόν
- HR** potvrđuje sljedeću usklađenost prema smjernicama EU i normama za artikl
- HR** potvrđuje sljedeću usklađenost prema smjernicama EU i normama za artikl
- RS** potvrđuje sledeću usklađenost prema smernicama EZ i normama za artikal
- RUS** следующим удостоверяется, что следующие продукты соответствуют директивам и нормам ЕС
- UKR** проголошує про зазначену нижче відповідність виробу директивам та стандартам ЄС на виріб
- MK** ja izjavuva slednata soobrznost согласно EU-директивата и нормите за артикли
- TR**  r n  ile ilgili AB direktifleri ve normları gereğince a ağıda açıklanan uygunluęu belirtir
- N** erkl rer f lgende samsvar i henhold til EU-direktivet og standarder for artikkel
- IS** L syr uppt llingu EU-reglna og annarra sta la v ru

Drag, crosscut and miter saw SCMS-2125U (Ozito)

- | | |
|---|--|
| <input type="checkbox"/> 2014/29/EU | <input checked="" type="checkbox"/> 2006/42/EC |
| <input type="checkbox"/> 2005/32/EC_2009/125/EC | <input type="checkbox"/> Annex IV
Notified Body:
Reg. No.: |
| <input type="checkbox"/> 2014/35/EU | <input type="checkbox"/> 2000/14/EC_2005/88/EC |
| <input type="checkbox"/> 2006/28/EC | <input type="checkbox"/> Annex V |
| <input checked="" type="checkbox"/> 2014/30/EU | <input type="checkbox"/> Annex VI
Noise: measured $L_{WA} = dB (A)$; guaranteed $L_{WA} = dB (A)$
$P = KW$; $L/\varnothing = cm$
Notified Body: |
| <input type="checkbox"/> 2014/32/EU | <input type="checkbox"/> 2012/46/EU_(EU)2016/1628
Emission No.: |
| <input type="checkbox"/> 2014/53/EU | |
| <input type="checkbox"/> 2014/68/EU | |
| <input type="checkbox"/> (EU)2016/426
Notified Body: | |
| <input type="checkbox"/> (EU)2016/425 | |
| <input checked="" type="checkbox"/> 2011/65/EU_(EU)2015/863 | |

Standard references: EN 62841-1; EN 62841-3-9; EN 60825-1;
EN 55014-1; EN 55014-2; EN 61000-3-2; EN 61000-3-3

Landau/Isar, den 10.10.2019

Andreas Weichselgartner/General-Manager

Dong/Product-Management

First CE: 19
Art.-No.: 43.008.16 I.-No.: 11039
Subject to change without notice

Archive-File/Record: NAPR022582
Documents registrar: Korbinian Wasmeier
Wiesenweg 22, D-94405 Landau/Isar

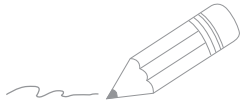

A series of 20 horizontal lines, evenly spaced, providing a template for writing or drawing.

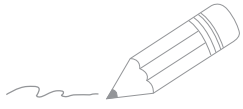

A series of horizontal lines for writing, starting from the pencil tip and extending across the page.

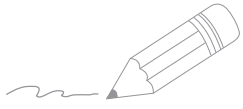

A series of horizontal lines for writing, starting with a pencil icon at the beginning of the first line.



EH 12/2019 (01)

