



Einhell

BLUE

BG-DP 5225 N Dirt water pump

Art.-No. 41.704.80

Powerful and robust dirt water pump to empty garden ponds, flooded basements and construction sites. It takes foreign particles up Ø 25 mm in size. The pump is equipped with a float switch for automatic ON/OFF operation for a varying water level. High quality material is used, like stainless steel drive unit and excellent axial face seal warrant an almost maintenance-free and long-life semi-professional use. The fine-tuning between motor and drive-wheel warrant a high effectiveness in delivery.

Features

- Handle (1)
- Float switch (2)
- Universal connection for 25 mm (1") and 32 mm (1¼") male thread hose connection as well as G1 (33.3 mm) male thread
- 90° angle bracket with G1½ (ca. 47.8 mm) male thread x G1½ (ca. 47.8 mm) male thread (3)
- Cable reel (4)
- High quality floating ring seal (5)

Technical Data

- Mains: 230 V ~ 50 Hz
- Power: 520 W
- Delivery capacity max.: 10,000 l/h
- Delivery height max.: 7 m
- Immersion depth: 5 m
- Water temperature: up to 35 °C
- Hose connection: G1½ (ca. 47.8 mm) female thread
- Foreign particle size up to: Ø 25 mm
- Mains cable: 10 m H05RN-F
- ON function: approx. 50 cm
- OFF function: approx. 5 cm
- Exhaust height: approx. 40 mm
- Net weight: 5 kg
- Gross weight: 5.4 kg
- Packing dimensions: 220 x 180 x 370 mm
- Bar code: 4006825556193
- Sales unit: 4 pcs



Performance data:

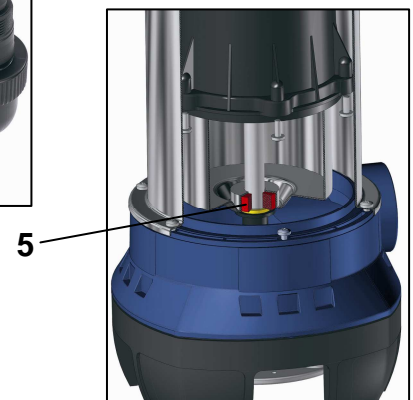
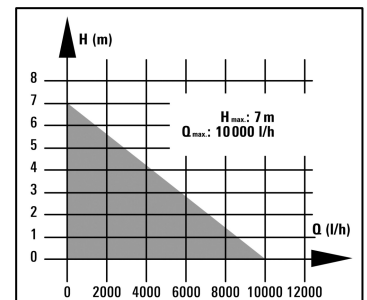

As special accessory available:

PVC-drainage hose 10 m/1"
Einhell Grey

Art.-No.: 41.737.14
Bar code: 4006825549249

