

## MAINTENANCE

**WARNING:** BEFORE CLEANING OR CARRYING OUT ANY MAINTENANCE PROCEDURE, ENSURE THE UNIT IS SWITCHED OFF, DISCONNECTED FROM THE POWER SUPPLY AND ALLOWED TO COOL DOWN.

### Cleaning

• Keep the ventilation vents of the air pump clean at all times, if possible, prevent foreign matter from entering the vents.

• After each use, blow air through the air pump housing to ensure it is free from all dust particles which may build up. Build up of dust particles may cause the air pump to overheat and fail.

• If the enclosure of the air pump requires cleaning do not use solvents but a moist soft cloth only. Never let any liquid get inside the product; never immerse any part of the air pump into a liquid.

**Note:** Ozito Industries will not be responsible for any damage or injuries caused by the repair of the air pump by an unauthorised person or by mishandling of the product.

**IMPORTANT:** STORE THE AIR PUMP ONLY IN A DRY LOCATION WHICH IS NOT ACCESSIBLE TO UNAUTHORISED PERSONS.

## TROUBLESHOOTING

Problem	Cause	Solution
The air pump does not start	Cord not connected to the power	Connect the power cord to a 240V power outlet
	On/off switch not in on position	Push the on/off switch into the on position
Adaptors disconnect when the pump switches on	Loose adaptor	Ensure the adaptor is pushed tightly onto the air port
Pump is operating but the inflatable item is not inflating/deflating	Some inflatable items have a check valve that require pinching or unscrewing	Pinch or unscrew the items valve while operating the pump
Pump is overheating	While inflating, the deflation port is being obstructed, restricting the flow of the air pump	Ensure the deflation port is free of any obstructions
	While deflating, the inflation port is being obstructed, restricting the flow of the air pump	Ensure the inflation port is free of any obstructions

## DESCRIPTION OF SYMBOLS

<b>V</b>	Volts	<b>Hz</b>	Hertz
<b>~</b>	Alternating current	<b>W</b>	Watts
<b>/min</b>	Revolutions or reciprocation per minute	<b>No</b>	No load speed
<b>A</b>	Amps	<b>°C</b>	Degrees Celsius
	Double insulated	<b>kPa</b>	Pressure rating (kilopascals)
<b>bar</b>	Pressure rating	<b>l</b>	Litres
	Warning		Read instruction manual

## SPARE PARTS

Spare parts can be ordered from the Special Orders Desk at your local Bunnings Warehouse or Homebase store.

For further information, or any parts visit

[www.ozito-diy.co.uk](http://www.ozito-diy.co.uk) or contact Ozito Customer Service:

Great Britain: 0151 294 4488

Ireland: 1850 882711

E-mail: [enquires@ozito-diy.co.uk](mailto:enquires@ozito-diy.co.uk)

## ELECTRICAL SAFETY

**WARNING!** When using mains-powered tools, basic safety precautions, including the following, should always be followed to reduce risk of fire, electric shock, personal injury and material damage. Read the whole manual carefully and make sure you know how to switch the tool off in an emergency, before operating the tool. Save these instructions and other documents supplied with this tool for future reference.

Before you connect the equipment to the mains supply make sure that the data on the rating plate are identical to the mains data.

This tool is double insulated therefore no earth wire is required.

## GENERAL POWER TOOL SAFETY WARNINGS-PERSONAL SAFETY

**WARNING!** Read all safety warnings and all instructions. Failure to follow the warnings and instructions may result in electric shock, fire and/or serious injury. Save all warnings and instructions for future reference. The term "power tool" in the warnings refers to your mains-operated (corded) power tool or battery-operated (cordless) power tool.

- Work area safety**
  - Keep work area clean and well lit.** Cluttered or dark areas invite accidents.
  - Do not operate power tools in explosive atmospheres, such as in the presence of flammable liquids, gases or dust.** Power tools create sparks which may ignite the dust or fumes.
  - Keep children and bystanders away while operating a power tool.** Distractions can cause you to lose control.
- Electrical safety**
  - Power tool plugs must match the outlet. Never modify the plug in any way. Do not use any adapter plugs with earthed (grounded) power tools.** Unmodified plugs and matching outlets will reduce risk of electric shock.
  - Avoid body contact with earthed or grounded surfaces, such as pipes, radiators, ranges and refrigerators.** There is an increased risk of electric shock if your body is earthed or grounded.
  - Do not expose power tools to rain or wet conditions.** Water entering a power tool will increase the risk of electric shock.
  - Do not abuse the cord. Never use the cord for carrying, pulling or unplugging the power tool. Keep cord away from heat, oil, sharp edges or moving parts.** Damaged or entangled cords increase the risk of electric shock.
  - When operating a power tool outdoors, use an extension cord suitable for outdoor use.** Use of a cord suitable for outdoor use reduces the risk of electric shock.
  - If operating a power tool in a damp location is unavoidable, use a residual current device (RCD) protected supply.** Use of an RCD reduces the risk of electric shock.
- Personal safety**
  - Stay alert, watch what you are doing and use common sense when operating a power tool. Do not use a power tool while you are tired or under the influence of drugs, alcohol or medication.** A moment of inattention while operating power tools may result in serious personal injury.
  - Use personal protective equipment. Always wear eye protection.** Protective equipment such as dust mask, non-skid safety shoes, hard hat, or hearing protection used for appropriate conditions will reduce personal injuries.
  - Prevent unintentional starting. Ensure the switch is in the off-position before connecting to power source and/or battery pack, picking up or carrying the tool.** Carrying power tools with your finger on the switch or energising power tools that have the switch on invites accidents.
- Remove any adjusting key or wrench before turning the power tool on.** A wrench or a key left attached to a rotating part of the power tool may result in personal injury.
- Do not overreach. Keep proper footing and balance at all times.** This enables better control of the power tool in unexpected situations.
- Dress properly. Do not wear loose clothing or jewellery. Keep your hair, clothing and gloves away from moving parts.** Loose clothes, jewellery or long hair can be caught in moving parts.
- If devices are provided for the connection of dust extraction and collection facilities, ensure these are connected and properly used.** Use of dust collection can reduce dust-related hazards.
- Power tool use and care**
  - Do not force the power tool. Use the correct power tool for your application.** The correct power tool will do the job better and safer at the rate for which it was designed.
  - Do not use the power tool if the switch does not turn it on and off.** Any power tool that cannot be controlled with the switch is dangerous and must be repaired.
  - Disconnect the plug from the power source and/or the battery pack from the power tool before making any adjustments, changing accessories, or storing power tools.** Such preventive safety measures reduce the risk of starting the power tool accidentally.
  - Store idle power tools out of the reach of children and do not allow persons unfamiliar with the power tool or these instructions to operate the power tool.** Power tools are dangerous in the hands of untrained users.
  - Maintain power tools. Check for misalignment or binding of moving parts, breakage of parts and any other condition that may affect the power tool's operation. If damaged, have the power tool repaired before use.** Many accidents are caused by poorly maintained power tools.
  - Keep cutting tools sharp and clean.** Properly maintained cutting tools with sharp cutting edges are less likely to bind and are easier to control.
  - Use the power tool, accessories and tool bits etc. in accordance with these instructions, taking into account the working conditions and the work to be performed.** Use of the power tool for operations different from those intended could result in a hazardous situation.
- Service**
  - Have your power tool serviced by a qualified repair person using only identical replacement parts.** This will ensure that the safety of the power tool is maintained.

The supply cord cannot be replaced. If the cord is damaged the appliance should be scrapped.

**Note:** Double insulation does not take the place of normal safety precautions when operating this tool. The insulation system is for added protection against injury resulting from a possible electrical insulation failure within the tool.

### Using an Extension Lead

Always use an approved extension lead suitable for the power input of this tool. Before use, inspect the extension lead for signs of damage, wear and ageing. Replace the extension lead if damaged or defective. When using an extension lead on a reel, always unwind the lead completely. Use of an extension lead not suitable for the power input of the tool or which is damaged or defective may result in a risk of fire and electric shock.

# ozito

## ELECTRIC AIR PUMP

### 130W

### ORIGINAL INSTRUCTIONS

### SPECIFICATIONS

Voltage: 220-240V ~ 50/60Hz  
 Power: 130W  
 Max. Current: 0.62A  
 Max. Pressure: 0.04bar (0.6psi)  
 Flow Rate: 440l/min  
 Max. Run Time: 15min  
 Weight: 0.49kg

[ozito-diy.co.uk](http://ozito-diy.co.uk)

# 3 YEAR REPLACEMENT WARRANTY

### WHAT'S IN THE BOX



Electric Air Pump

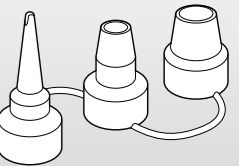

3 x Inflation Adaptors

## WARRANTY

All of our products undergo strict quality checks to ensure that they reach you in perfect condition. In the unlikely event that your device develops a fault, please contact our service department at the address shown on this guarantee card. You can also contact us by telephone using the customer service number shown. Please note the following terms under which guarantee claims can be made:

1. These warranty terms regulate additional warranty services, which the manufacturer mentioned below promises to buyers of its new products in addition to their statutory guarantee claims are not affected by this guarantee. Our guarantee is free of charge to you.

2. The warranty services only covers defects due to material or manufacturing faults on a product which you have bought from the manufacturer mentioned below are limited to either the rectification of said defects on the product or the replacement of the product, whichever we prefer. Please note that our devices are not designed for use in commercial, trade or professional applications. A guarantee contract will not be created if the device has been used by commercial, trade or industrial business or has been exposed to similar stresses during the guarantee period.

3. The following are not covered by our guarantee:  
 - Damage to the device caused by a failure to follow the assembly instructions or due to incorrect installation, a failure to follow the operating instructions (for example connecting it to an incorrect mains voltage or current type) or a failure to follow the maintenance and safety instructions or by exposing the device to abnormal environmental conditions or by lack of care and maintenance.  
 - Damage to the device caused by abuse or incorrect use (for example overloading the device or the use of unapproved tools or accessories), ingress of foreign bodies into the device (such as sand, stones or dust, transport damage), the use of force or damage caused by external forces (for example by dropping it).

- Damage to the device or parts of the device caused by normal or natural wear or tear or by normal use of the device.

4. Your Product is guaranteed for a period of 36 months from the original date of purchase and is intended for DIY (Do It Yourself) use only. Lithium Ion batteries and chargers are covered by a 12 month warranty. Warranty excludes consumable parts. Guarantee claims should be submitted before the end of the guarantee period within two weeks of the defect being noticed. No guarantee claims will be accepted after the end of the guarantee period. The original guarantee period remains applicable to the device even if repairs are carried out or parts are replaced. In such cases, the work performed or parts fitted will not result in an extension of the guarantee period, and no new guarantee will become active for the work performed or parts fitted. This also applies if an on-site service is used.

IN ORDER TO MAKE A CLAIM UNDER THIS WARRANTY YOU MUST RETURN THE PRODUCT TO THE PLACE OF PURCHASE WITH YOUR REGISTER RECEIPT.

Please refer to the restrictions of this warranty concerning wearing parts, consumables and missing parts as set out in the service information in these operating instructions.

CUSTOMER SERVICE HELPLINE  
 GB: 0151 294 4488  
 IRL: 1850 882711  
[Ozito-diy.co.uk](http://Ozito-diy.co.uk)

# KNOW YOUR PRODUCT

## ELECTRIC AIR PUMP

- 1 Inflation Port
- 2 On/Off Switch
- 3 Air Pump Housing
- 4 Deflation Port
- 5 Power Cord

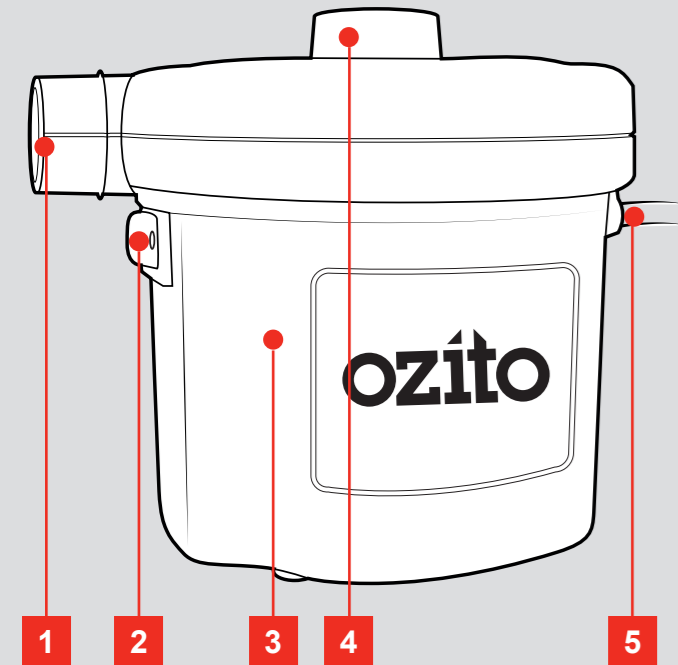

## ACCESSORIES

- 6 Inflation Adaptors

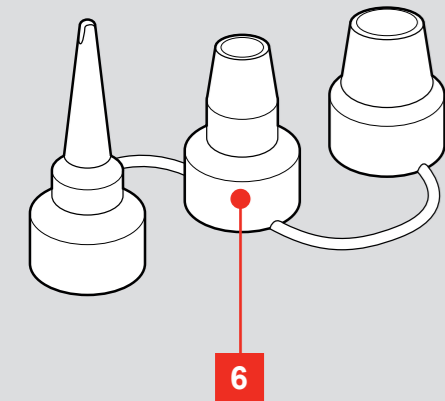

## ONLINE MANUAL

Scan this QR Code with your mobile device to take you to the online manual.



# SETUP & PREPARATION

## 1. ADAPTORS

**WARNING:** ENSURE THE TOOL IS SWITCHED OFF AND DISCONNECTED FROM THE POWER SUPPLY BEFORE PERFORMING ANY OF THE FOLLOWING STEPS.

### Fitting an Adaptor

- 1 Align the required adaptor with the port.

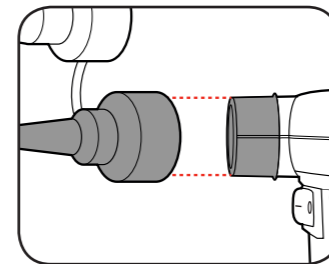

- 2 Push the adaptor onto the air port tightly.

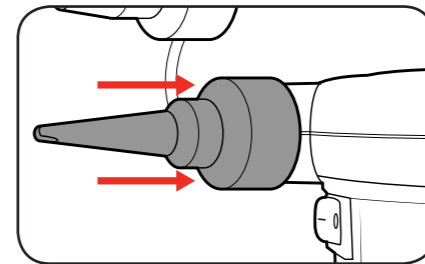

### Removing Adaptors

- 1 To remove, simply pull the adaptor from the air port.

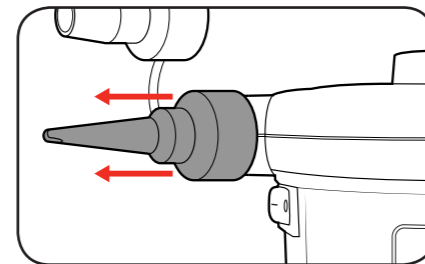

# OPERATION

## 2. SWITCHING ON & OFF

**CAUTION!** THE POWER SUPPLY FOR THIS PRODUCT SHOULD BE PROTECTED BY A RESIDUAL CURRENT DEVICE (RATED AT 30mA OR LESS).

- 1 To start operating the air pump, push the on/off switch to the on position.

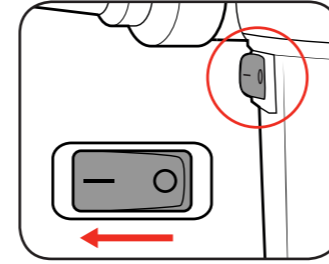

- 2 To stop operation, push the on/off switch to the off position.

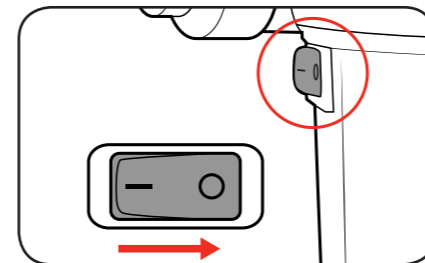

**WARNING:** COMPRESSED AIR CAN BE DANGEROUS. NEVER POINT THE OUTLET NOZZLE TOWARDS ANY PART OF YOUR BODY OR AT ANOTHER PERSON.

## 3. INFLATING ITEMS

**IMPORTANT:** BEFORE CONNECTING OR DISCONNECTING ACCESSORIES, ALWAYS MAKE SURE THAT THE AIR PUMP IS TURNED OFF.

- 1 Fit the required adaptor onto the inflation port tightly.

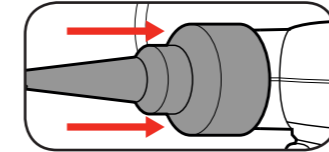

- 2 Insert the adaptor into the valve of the inflatable item.

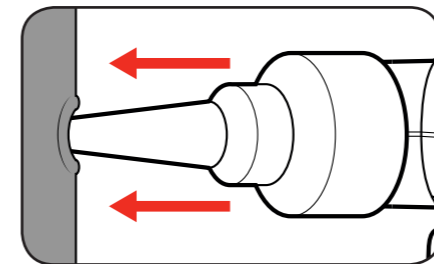

**CAUTION:** ENSURE THE DEFLATION PORT IS NOT OBSTRUCTED, OTHERWISE THE UNIT COULD OVERHEAT.

- 3 Switch the air pump on at the on/off switch.

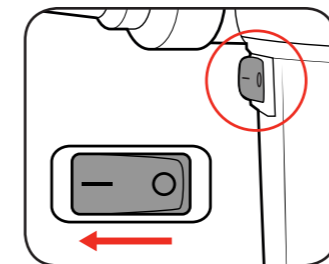

- 4 Once the item is inflated, switch the air pump off and then remove the adaptor from the valve.

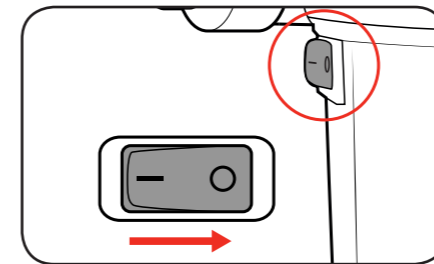

**WARNING:** AVOID INFLATING THE OBJECTS ABOVE THE RECOMMENDED INFLATION PRESSURE. THIS MAY LEAD TO DAMAGE AND/OR INJURIES.

## 4. DEFLATING ITEMS

**IMPORTANT:** BEFORE CONNECTING OR DISCONNECTING ACCESSORIES, ALWAYS MAKE SURE THAT THE AIR PUMP IS TURNED OFF.

- 1 Fit the required adaptor onto the deflation port at the top of the unit tightly.

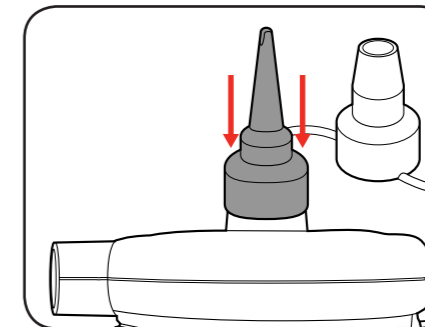

- 2 Insert the adaptor into the valve of the inflatable item.

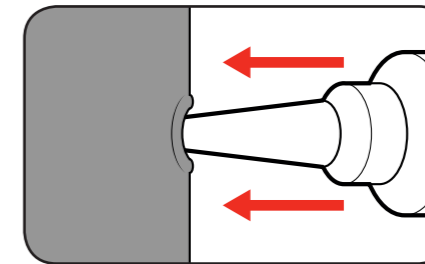

**CAUTION:** ENSURE THE INFLATION PORT IS NOT OBSTRUCTED, OTHERWISE THE UNIT COULD OVERHEAT.

- 3 Switch the air pump on at the on/off switch.

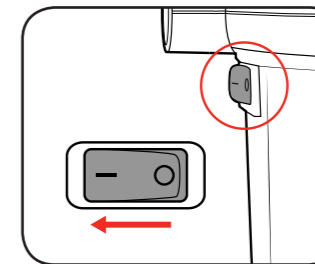

- 4 Once the item is deflated, switch the air pump off and then remove the adaptor from the valve.

