

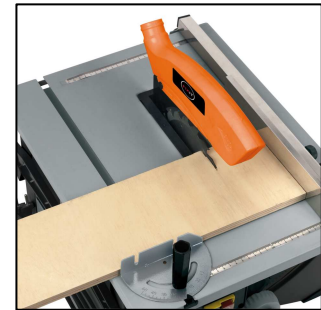

The NTK 900 table saw has been designed for multi-purpose applications including ripping and crosscuts of lumber, chipboard, plywood, multiplex board and veneered board. The saw can be tilted up to 45° for mitre cuts. Thanks to its compact construction the circular saw is ideal for mobile applications. The parallel stop with two stopping heights guarantees precise cuts.

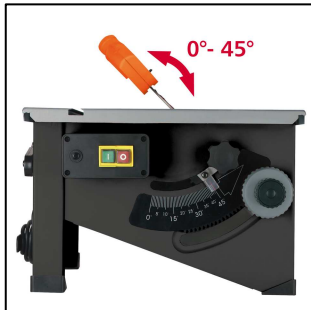

## NTK 900 Table saw

Available as special accessory:

**Carbide-tipped saw blade:**  
Ø 205 x Ø 16 x 2.5 mm 48 teeth

**Art. No.:** 45.020.33  
**Ident. No.:** 01023  
**Bar Code:** 4006825 456172

**Carbide-tipped saw blade:**  
Ø 205 x Ø 16 x 2.5 mm 20 teeth

**Art. No.:** 45.020.39  
**Ident. No.:** 01013  
**Bar Code:** 4006825 456066

### Logistic Information:

**Type:** NTK 900  
**Art. No.:** 43.407.31  
**Ident. No.:** 01017  
**Bar Code:** 4006825 539684  
**Packing:** 560 x 440 x 315 mm

**Sales unit:** 1 pc  
**20`:`:** 364 pcs  
**40`:`:** 756 pcs  
**40``HC:** 864 pcs  
**Weight:** 16 kgs (gross)



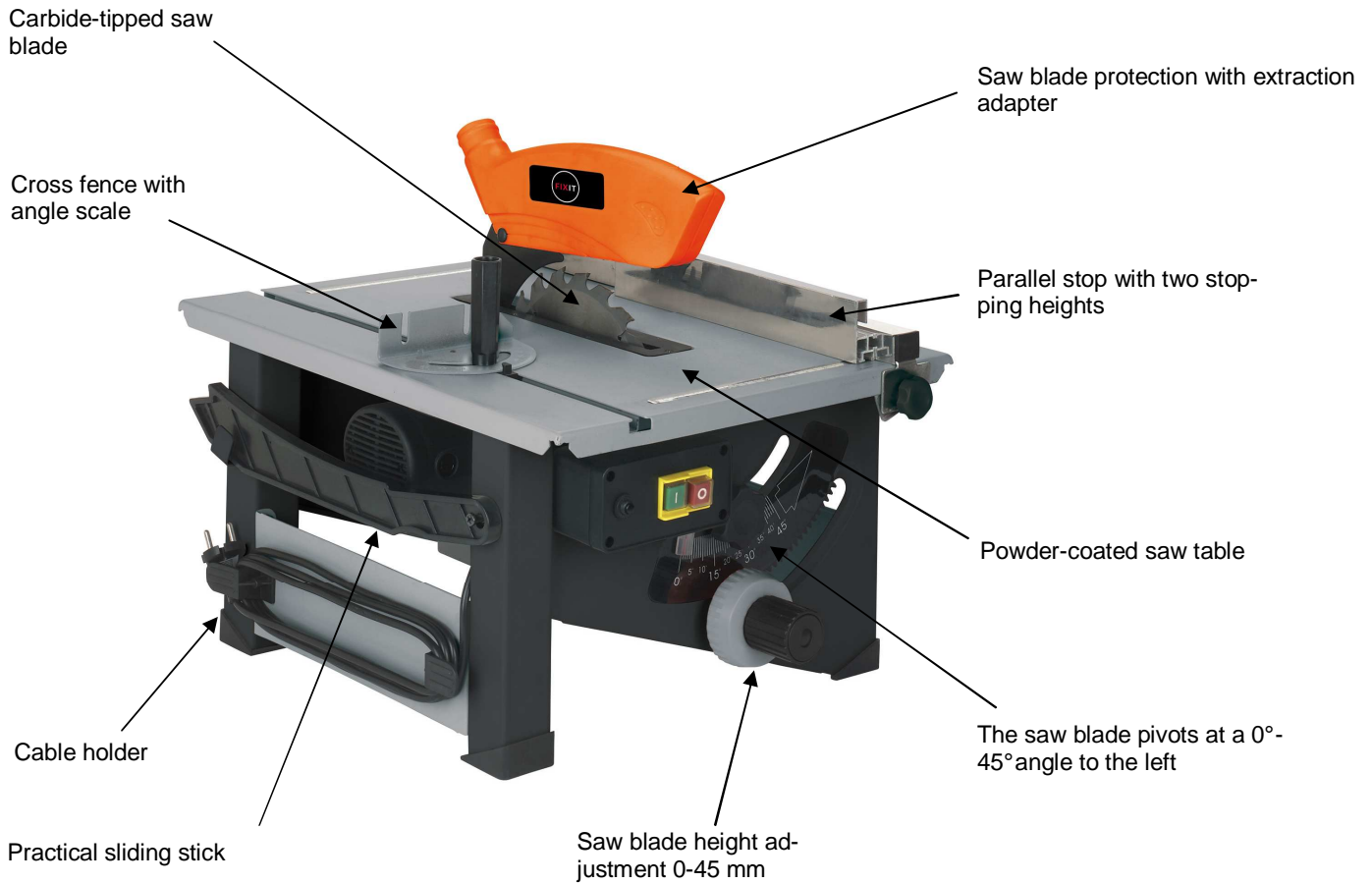

#### Features:

- The saw blade pivots at a 0°- 45° angle to the left
- Saw blade height adjustment 0-45 mm
- Adjustable parallel stop with two stopping heights
- Cross fence with angle scale
- Saw blade protection with extraction adapter
- Practical sliding stick

#### Technical Data:

- |                                |                         |
|--------------------------------|-------------------------|
| - Mains:                       | 230 V ~ 50 Hz           |
| - Power:                       | 900 watts               |
| - Idle speed $n_0$ :           | 3,800 min <sup>-1</sup> |
| - Carbide-tipped saw blade:    | Ø 205 x 16 x 2.5 mm     |
| - No. of teeth:                | 20                      |
| - Cutting height 90°/45° max.: | 45 mm / 41 mm           |
| - Table size:                  | 513 x 400 mm            |
| - Adapter for dust extraction: | Ø 36 mm                 |

#### Logistic Information:

<b>Type:</b>	<b>NTK 900</b>	<b>Tool:</b>	<b>Table saw</b>
<b>Art. No.:</b>	43.407.31	<b>Sales unit:</b>	1 pc
<b>Ident. No.:</b>	01017	<b>20`:`:</b>	364 pcs
<b>Bar Code:</b>	4006825 539684	<b>40`:`:</b>	756 pcs
<b>Packing:</b>	560 x 440 x 315 mm	<b>40``HC:</b>	864 pcs
		<b>Weight:</b>	16 kgs (gross)

