



TABLE SAW 1700W

USER GUIDE

Important: retain for future reference - please read carefully.

Now you have purchased a WORKZONE® product you can rest assured in the knowledge that as well as your 3 year parts and labour guarantee you have the added peace of mind of dedicated helplines and web support.

AFTER SALES SUPPORT

☎ 1300 922 271  service.australia@einhell.com

WZTS 1701

09/2013

Congratulations!

You have made an excellent choice with the purchase of this quality WORKZONE® product.

By doing so you now have the assurance and peace of mind which comes from purchasing a product that has been manufactured to the highest standards of performance and safety, supported by the high quality standards of ALDI.

We want you to be completely satisfied with your purchase so this WORKZONE® product is backed by a comprehensive manufacturer's **3** year warranty and an outstanding after sales service through our dedicated Helpline.

We hope you will enjoy using your purchase for many years to come.

If you require technical support or in the unlikely event that your purchase is faulty please telephone our Helpline for immediate assistance. Faulty product claims made within the **3** year warranty period will be repaired or replaced free of charge provided that you have satisfactory proof of purchase (keep your till receipt safe!). This does not affect your statutory rights. However, be aware that the warranty will become null and void if the product is found to have been deliberately damaged, misused or disassembled.



Table of contents

Pg. 04	Safety information
Pg. 16	Items supplied
Pg. 17	Layout
Pg. 18	Instructions for use
Pg. 21	Before starting the equipment
Pg. 29	Operation
Pg. 41	Data
Pg. 46	Guarantee Certificate



Safety information

1

⚠ Caution!

When using the equipment, a number of safety precautions must be observed to avoid injuries and damage. Please read the complete operating instructions and safety information with due care. Keep these operating instructions in a safe place so that the information is available at all times. If you give the equipment to any other person, hand over these operating instructions and the safety information as well. We cannot accept any liability for damage or accidents which arise due to failure to follow these instructions and the safety information.

⚠ WARNING

Read all the safety information and instructions. Failure to adhere to the safety information and instructions set out below may result in electric shock, fire and/or serious injury.
Keep all the safety information and instructions in a safe place for future use.



Important: Laser radiation
Do not look into the beam
Laser class 2

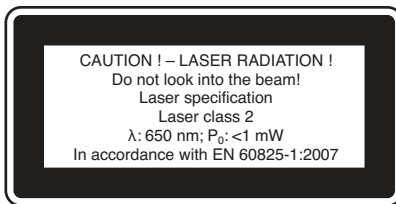

Protect yourself and your environment from risks and accidents by taking the appropriate precautionary measures.

- Do not look directly into the laser beam with the naked eye.
- Never look directly into the laser path.
- Never direct the laser beam at reflecting surfaces or persons or animals. Even a low output laser beam can inflict injury on the eye.
- Caution: It is vital to follow the work procedures described in these instructions. Using the equipment in any other way may result in hazardous exposure to laser radiation or radioactive contamination.
- Never open the laser module.

Use of the batteries

- Ensure that the ON/OFF switch for the laser (32) is set to its "0" position before you fit the batteries.
- Inserting the batteries when the laser is switched on can cause accidents.
- If the equipment is not used correctly the batteries may leak. Avoid contact with the battery fluid. If you come into contact with battery fluid, clean the affected body part with running water. If you get battery fluid in your eyes, seek immediate medical assistance.
- Leaked battery fluid can cause skin irritation and acid burns.
- Never expose the batteries to excess heat such as direct sunlight or fire etc.
- Never recharge batteries that are not suitable for recharging. There is a risk of explosion!
- Keep batteries away from children, do not short circuit batteries or disassemble.
- Seek a doctor's advice immediately if a battery is swallowed.
- If necessary, clean the contacts on the battery and equipment before inserting the batteries.
- Ensure that you insert the batteries correctly.
- Remove flat batteries immediately from the equipment. There is an increased risk of leakage.
- Always change all batteries at the same time.



- Insert only batteries of the same type, do not use different types of batteries or used and new batteries together.
- Make sure that the equipment is switched off after use.
- Remove the batteries if the equipment is not used over a longer period.

1.1. Safety information for the table saw

Important! The following basic safety actions must be taken when using electric tools in order to protect the user from electric shocks and the risk of injury and fire. Read all the following information before you use the electric tool and keep these safety instructions in a safe place.

1. **Keep your work area tidy**
 - Untidy work areas can result in accidents.
2. **Make allowance for ambient conditions**
 - Do not expose electric tools to rain. Never use electric tools in damp or wet locations. Provide good lighting. Do not use electric tools near flammable liquids or gases.
3. **Guard against electric shock**
 - Avoid bodily contact with earthed parts (e.g. pipes, radiators, cookers and refrigerators).
4. **Keep other persons away!**
 - Do not allow other persons, particularly children, to touch the tool or cable, keep them away from your work area.
5. **Keep your electric power tools in a safe place**
 - Unused tools should be stored in a dry, locked room out of children's reach.
6. **Do not overload your tools**
 - Tools work better and safer when used within their quoted capacity range.
7. **Use the right tool.**
 - Do not use tools or attachments too weak for heavy duty work. Never use tools on jobs for which they are not intended; for example, do not use a hand-held circular saw to cut trees or lop off branches.
8. **Wear suitable work clothes**
 - Never wear loose fitting clothes or jewellery. They may get caught in moving parts. Rubber gloves and non-slip shoes are recommended when working outdoors. Wear a hair net if you have long hair.



9. **Use personal safety equipment**
 - Wear safety goggles.
 - Use a dust mask when working on dusty jobs.
10. **Do not use the cable for purposes other than that for which it is designed**
 - Do not carry the tool by its cable and do not use the cable to pull the plug out of the socket. Protect the cable from heat, oil and sharp edges.
11. **Secure your workpiece**
 - Use clamps or a vice to hold the workpiece securely. This is safer than using your hands and also enables you to operate the machine with both hands.
12. **Avoid abnormal working postures**
 - Make sure you stand squarely and keep your balance at all times.
13. **Take care of your tools**
 - Keep your tools sharp and clean in order to work well and safely. Follow the maintenance information and the instructions for changing tools. Check the power plug and cable on a regular basis and have them replaced by an authorised specialist if they are damaged. Check the extension cable regularly and replace it if damaged. Keep handles dry and free from oil and grease.
14. **Disconnect the power plug**
 - When tools are not in use, before starting any maintenance work or when changing attachments such as saw blades, drill bits and all kinds of mounted tools.
15. **Always remove keys and wrenches after use**
 - Before switching on the machine, make sure that all keys and wrenches have been removed from the equipment.
16. **Avoid unintentional starting**
 - Never carry a tool with your finger on the switch button while the tool is connected to the power supply. Make sure that the switch is turned off when connecting the tool to the power supply.
17. **When using an extension cable outdoors**
 - Check that it is approved for outdoor duty and is marked accordingly.
18. **Be alert at all times**
 - Keep an eye on your work. Use common sense when working. Never use the tool when you are distracted.



19. **Check the equipment for damage**

- Before using the tool again, check the safety devices or any slightly damaged parts to ensure that they are in good working order. Check that the moving parts are working correctly, that they do not jam, and that no parts are damaged. Make sure that all parts are fitted correctly to ensure that the equipment remains safe to use. Unless otherwise stated in the operating instructions, damaged guards, damaged switches and parts have to be repaired or replaced by an authorized technician. Never use tools with a switch that cannot be turned on and off.

20. **Important!**

- For your own safety you must only use the accessories and additional units listed in the operating instructions as recommended or specified by the manufacturer. The use of mounted tools or accessories other than those recommended in the operating instructions or catalog may place your personal safety at risk.

21. **Repairs may only be carried out by a qualified electrician**

- This electric tool complies with the pertinent safety regulations. Repairs are to be carried out only by a qualified electrician using original replacement parts or the user may suffer an accident.

22. **Connecting a vacuum dust extraction system**

- If there are provisions for connecting a vacuum dust extraction system, make sure that such a system is fitted and in use.

1.2. Special safety information

1.2.1. Safety precautions

- Blades that are deformed or cracked must not be used.
- If the table insert is worn, replace it.
- Use only blades which are recommended by the manufacturer and comply with EN 847-1. When changing the blade, make sure that the cutting width is not smaller and the saw plate not bigger than the thickness of the splitter.
- Make sure that the chosen blade is suitable for the material that is to be cut.



- If necessary, wear suitable personal protection equipment.
This could consist of:
 - Ear-muffs to reduce the risk of damaging your hearing
 - A breathing mask to reduce the risk of inhaling hazardous dust
 - Always wear gloves when handling saw blades and rough materials.
 Carry saw blades in a container to avoid injuries.
- The following can have an influence on dust development:
 - Worn, damaged or cracked saw blades
 - Recommended capacity of the vacuum extraction system: 20 m/s
 - Proper guidance of the workpiece
- Blades made of high-alloy high-speed steel (HSS) must not be used.
- Keep the push stick or handle for a push block at the machine at all times, even when you are not using them.

1.2.2. Maintenance and service

- The following conditions can have an influence on noise impact on the operator:
 - Type of saw blade (e.g. saw blades designed to reduce noise development)
 - Material of the workpiece
 - The force with which the workpiece is pushed against the saw blade
- Faults on the machine or its guards, safety devices and blade must be reported to the person in charge as soon as they are discovered.

1.2.3. Safe operation

- Use a push stick or the handle with a push block to feed the workpiece safely past the saw blade.
- Use the splitter and set it correctly.
- Use the upper blade guard and set it to the correct position.
- Do not cut rebates or grooves without fitting a suitable guard, e.g. a tunnel-type guard, over the saw table.
- Circular saws must not be used for slotting jobs (cutting grooves which end in the workpiece).
- Use only blades where the permissible maximum speed is not lower than the maximum spindle speed of the bench-type circular saw and which are suitable for the material to be cut.



- Use only the transport devices to move the equipment. Never use the guards for handling or moving the equipment. Handle openings for transport purposes are on both sides of the saw housing.
- While you are moving the machine it is best to cover the top part of the blade, e.g. with the guard.
- Prevent long workpieces from falling off the end of the cut by using a roller stand etc.

1.2.4. Additional instructions

- Give these safety instructions to all persons who work on the machine.
- Do not use this saw to cut fire wood.
- Do not use this saw to cross-cut roundwood.
- Caution! Hands and fingers may be injured on the rotating saw blade.
- The machine is equipped with a safety switch to prevent it from being switched on again accidentally after a power failure.
- Before you use the machine for the first time, check that the voltage marked on the rating plate is the same as your supply voltage.
- If you need to use an extension cable, make sure its conductor cross-section is big enough for the saw's power consumption. Minimum cross-section: 1 mm².
- If you use a cable reel, the complete cable must be pulled off the reel.
- Check the power cable. Never use a faulty or damaged power cable.
- Operators have to be at least 18 years of age. Trainees of at least 16 years of age are allowed to use the machine under supervision.
- Keep your workplace clean of wood scrap and any unnecessary objects.
- Persons working on the machine should not be distracted.
- Note the direction of rotation of the motor and saw blade.
- After you have switched off the motor, never slow down the saw blade by applying pressure to its side.
- Only fit blades which are well sharpened and have no cracks or deformations.
- Never dismantle the machine's safety devices or render them inoperative.
- Faulty saw blades must be replaced immediately.
- Never use saw blades which do not comply with the data specified in these operating instructions.



- It is imperative to make sure that all devices which cover the saw blade are in good working order.
- **Important:** It is prohibited to use this saw to make plunge cuts.
- Damaged or faulty safety devices have to be replaced immediately.
- The splitter is an important safety device. Not only does it guide the workpiece, it also prevents the kerf closing behind the blade so that there is no kickback from the workpiece. Note the thickness of the splitter. The splitter should never be thinner than the saw blade body or thicker than the width of its kerf.
- The guard hood has to be lowered over the workpiece for each cut.
- Be sure to use a push stick when slitting narrow workpieces (smaller than 120 mm in width).
- Never cut workpieces which are too small to hold securely in your hand.
- It is imperative for the parallel stop to be clamped on the right-hand side of the blade whenever you cut narrow workpieces to size.
- Always stand to the side of the saw blade when working with the saw.
- Never load the machine so much that it cuts out.
- Always press the workpiece firmly against the saw table.
- Make sure that off-cuts do not catch on the saw blade crown. Risk of catapulting!
- Refit all guards and safety devices immediately after you have completed any repairs or maintenance work.
- Be sure to observe the safety information and operating and maintenance instructions issued by the manufacturer, as well as the dimensions listed in the Technical Data.
- It is imperative to observe the accident prevention regulations in force in your area as well as all other generally recognised rules of safety.
- Note the information published by your professional associations.
- Connect up the dust extraction system on all jobs. The operator has to be informed about the conditions with an influence on dust development, e.g. the type of material being processed (source and collection of the dust), the significance of local separation arrangements, and the correct setting of hoods, baffle plates and guides.



- Operate the saw only with a suitable vacuum dust extraction system or a standard industrial vacuum cleaner.
- Never remove loose splinters, chips or jammed pieces of wood when the saw blade is running.
- To rectify faults or remove jammed pieces of wood, always switch off the machine first.
 - Disconnect power plug
- If the sawing gap is worn, replace the table insert.
 - Disconnect power plug
- This tool complies with the pertinent safety regulations.
- Keep the tool out of the rain and away from moisture. The ingress of water into an electric power tool increases the risk of an electric shock.
- Be careful, watch what you are doing and use an electric tool sensibly. Never use the tool if you are tired or under the influence of drugs, alcohol or medication. A moment of inattention when using the electric tool can result in serious injuries.
- Do not use an electric power tool if the switch is defective. An electric power tool that cannot be switched on or off is dangerous and must be repaired.
- Keep unused electric tools out of the reach of children. Do not allow people who are not familiar with the tool or who have not read these instructions to use the tool.
- Electric tools are dangerous if they are used by inexperienced people.
- Keep your cutting tools sharp and clean. Carefully maintained cutting tools with sharp cutting edges will jam less and are easier to control.
- If the power cable for this equipment is damaged, it must be replaced by the manufacturer's after-sales service or by similarly trained personnel to avoid danger.
- Have your tool repaired only by trained personnel using only genuine spare parts. This will ensure that your tool remains safe to use.
- The equipment has to be set up where it can stand securely.
- All covers and safety devices have to be properly fitted before the equipment is switched on.
- It must be possible for the blade to run freely.
- When working with wood that has been processed before, watch out for foreign bodies such as nails or screws etc.



- Before you actuate the On/Off switch, make sure that the saw blade is correctly fitted and that the equipment's moving parts run smoothly.
- Follow the instructions for lubrication and changing tools.
- Keep handles dry, clean and free from oil and grease.

Safety information for handling saw blades

1. Tools are allowed to be used only by trained and experienced persons who are familiar with the handling of tools.
2. The maximum speed specified on the tool is not allowed to be exceeded.
3. Circular saw blades that are cracked or damaged must not be used. No repairs are permitted.
4. Mount the tools and tool bodies so that they cannot come loose during operation.
5. When fitting the tools, make sure that they are clamped at the tool hub or tool clamping face and that the cutting edges do not touch each other or the clamping elements.
6. Fastening screws and nuts must be tightened with a suitable wrench or similar and with the torque specified by the manufacturer.
7. The extension of wrenches or the use of striking tools for tightening purposes is not permitted.
8. All dirt, oil and water must be cleaned off the clamping faces.
9. Please observe the information supplied by the manufacturer regarding the tightening of clamp screws. If no instructions are supplied, the clamp screws must be tightened in sequence starting from the center and working outwards.
10. Light alloys may only be deresinated with solvents which do not reduce with properties of the material.
11. The use of loose reducing rings or reducer sleeves for reducing the boreholes of circular saw blades is not permitted. The use of rings which are permanently fitted, e.g. pressed-in or held in by glue, in circular saw blades, or of flanged bushings on other tools, is permissible if they are produced in accordance with the manufacturer's specifications.



12. Given the production tolerances involved, it may be necessary to tap the reducing rings carefully into the borehole of the saw blade with a rubber mallet. To do so, place the area around the borehole of the saw blade on a firm surface (e.g. wood) with the teeth freely suspended during striking so that the saw blade does not get bent.
13. Replace the reducing ring with a new one (available from your dealer) if it no longer holds itself in the blade.
14. To prevent injuries, be sure to handle the tools in accordance with the manufacturer's instructions. Safe handling generally involves the use of devices such as conveyor hooks, manufacturer-specific holding devices, frames (for example for circular saw blades), boxes, trolleys, etc. Wearing safety gloves will provide a more secure grip on the tool and further reduce the risk of injury.
15. The handling of equipment with a weight of more than 15 kg may require the use of special devices or mounts depending on the design measures provided by the manufacturer for the easy handling of the equipment. The manufacturer may provide information on the availability of the required devices.
16. These saw blades are not suitable for resharpening.
17. Please observe the safety regulations of the related equipment.
18. Do not make any modifications to the tool.

Keep this safety information in a safe place.





Note the instructions for use!



Caution! Risk of injury! Never reach into the running saw blade.



Wear a breathing mask if dust is generated.



Wear ear-muffs.



Wear safety goggles.



Wear safety gloves.



Caution! Risk of injury from sharp edges!



Items supplied

2

- Open the packaging and take out the equipment with care.
- Remove the packaging material and any packaging and/or transportation braces (if present).
- Check to see if all the items are supplied.
- Inspect the equipment and accessories for transport damage.
- If possible, keep the packaging until the end of the guarantee period.

IMPORTANT

The equipment and packaging material are not toys. Do not let children play with plastic bags, plastic sheets and small parts. There is a risk of choking and suffocating!

- 1 x Table Saw
- 2 x Table width extension
- 1 x Table length extension
- 1 x Base frame
- 1 x Splitter with laser unit
- 1 x Stop rail
- 1 x Parallel stop
- 1 x Cross & parallel fence
- 1 x Cross stop
- 1 x Push stick
- 1 x Saw blade guard
- 1 x Dust extraction adapter
- 2 x 1.5 LR 03 batteries
- 1 x Instruction Manual
- 1 x Warranty Card
- 1 x Warranty Sticker



Layout

3

1. Saw table
2. Saw blade guard
3. Extraction hose
4. Splitter
5. Saw blade
6. Table insert
7. Parallel stop
8. Hand wheel
9. Adjusting and locking grip
10. Base frame
11. ON/OFF switch
12. Guide rail
13. Cross stop
14. Width extension table
15. Length extension table
16. Extractor adapter
17. Push stick
18. Legs
19. Longitudinal and cross struts
20. Center struts
21. Rubber feet
22. Stability bar
23. Table supports
24. Screw with wing nut
25. Oval hole in splitter
26. Countersunk head screws
27. Fixing screw
28. Eccentric lever
29. Groove
30. Knurled screw
31. Laser
32. Laser switch
33. Screws for battery compartment
34. Battery compartment cover



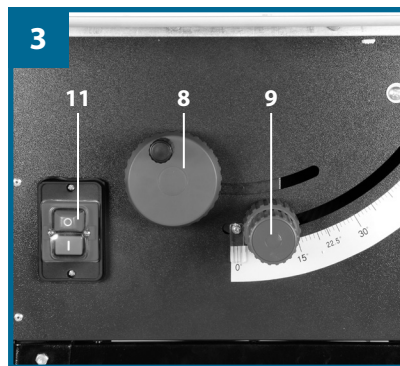
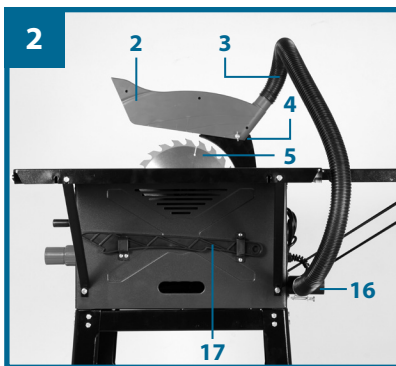
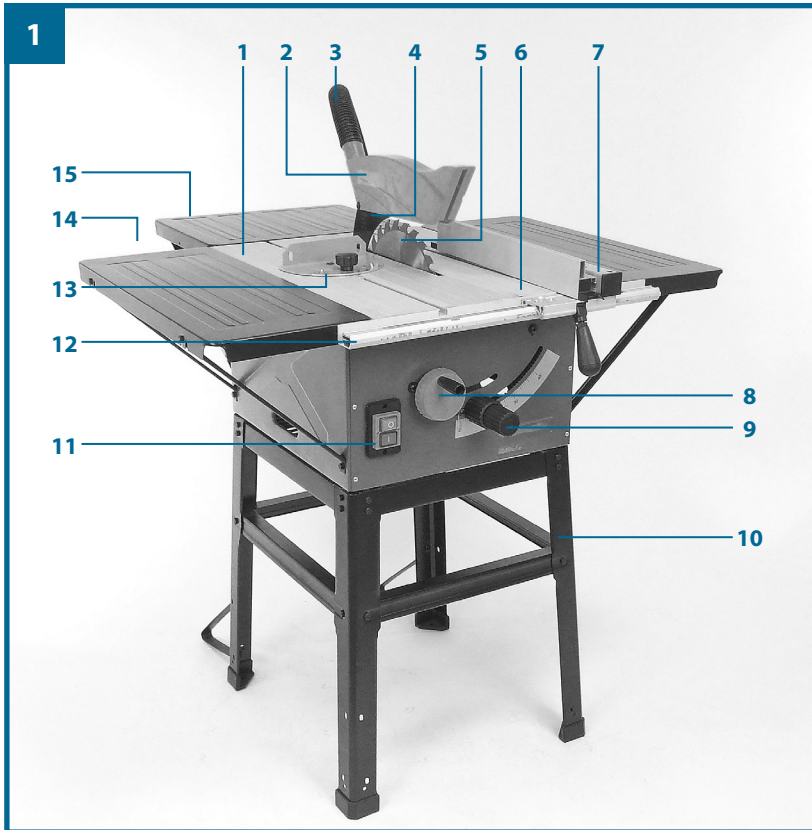

Instructions for use



The table saw is designed for the slitting and cross-cutting (only with the cross stop) of all types of timber commensurate with the machine's size. The machine is not to be used for cutting any type of round wood.

The equipment is allowed to be used only for its intended purpose. Any other use is deemed to be a case of misuse. The user/operator and not the manufacturer will be liable for any damage or injuries of any kind resulting from such misuse.

Please note that our equipment has not been designed for use in commercial, trade or industrial applications. Our warranty will be voided if the equipment is used in commercial, trade or industrial businesses or for equivalent purposes.

The equipment is to be operated only with suitable saw blades (saw blades made of HM or CV) It is prohibited to use any type of HSS saw blade and cutting-off wheel. Intended use also includes complying with the safety information, the assembly instructions and the operating instructions contained in the operating manual.

All persons who use and service the equipment have to be acquainted with these operating instructions and must be informed about the equipment's potential hazards. It is also imperative to observe the accident prevention regulations in force in your area. The same applies for the general rules of health and safety at work.

The manufacturer will not be liable for any changes made to the equipment nor for any damage resulting from such changes.

Even when the equipment is used as prescribed it is still impossible to eliminate certain residual risk factors. The following hazards may arise in connection with the equipment's construction and design:

- Contact with the saw blade in the uncovered saw zone.
- Reaching into the running saw blade (cut injuries).
- Kick-back of workpieces and parts of workpieces.
- Saw blade fracturing.
- Catapulting of faulty carbide tips from the saw blade.
- Damage to hearing if essential ear-muffs are not used.
- Harmful emissions of wood dust when used in closed rooms.



Before starting the equipment **5**

- Before you connect the equipment to the power supply make sure that the data on the rating plate are identical to the supply voltage.
- Only ever connect the equipment to a properly installed shock-proof socket which is protected by a 10A fuse as a minimum.
- Always pull out the power plug before making adjustments to the equipment.
- Unpack the table saw and check it for damage which may have occurred in transit.
- Make sure the machine stands securely, i.e. bolt it to a workbench or solid base.
- All covers and safety devices have to be properly fitted before the equipment is switched on.
- It must be possible for the blade to run freely.
- When working with wood that has been processed before, watch out for foreign bodies such as nails or screws, etc.
- Before you actuate the On/Off switch, make sure that the saw blade is correctly fitted and that the equipment's moving parts run smoothly.

Assembly

Important! Disconnect the power plug before carrying out any maintenance, resetting or assembly work on the circular saw!

You will need the following tools for the assembly work:

- Open-ended spanner or ring spanner size 10, size 24
- Allen key 4 mm
- Crosstip screwdriver PH2



5.1 Assembling the base frame (Fig. 4-9)

- Turn the saw upside down and place it on the floor.
- Use hex screws (c) and washers (a) to fasten the four legs (18) loosely to the saw (Fig. 5).
- Now loosely screw the longitudinal and cross struts (19) as well as the four center struts (20) to the legs using the hex screws (c), washers (a) and nuts (b) (Fig. 6-7)

Important: The longer struts have to be used on the sides.

- Now mount the four rubber feet (21) on the legs (18) (Fig. 8).
- Screw the stability bars (22) to the bore holes on the rear legs (18) using 2 hex screws (c), washers (a) and nuts (b) on each side. (Fig. 8)

Important! Both stability bars must be fastened to the back of the equipment!

- Finally, tighten all screws and nuts on the base frame.

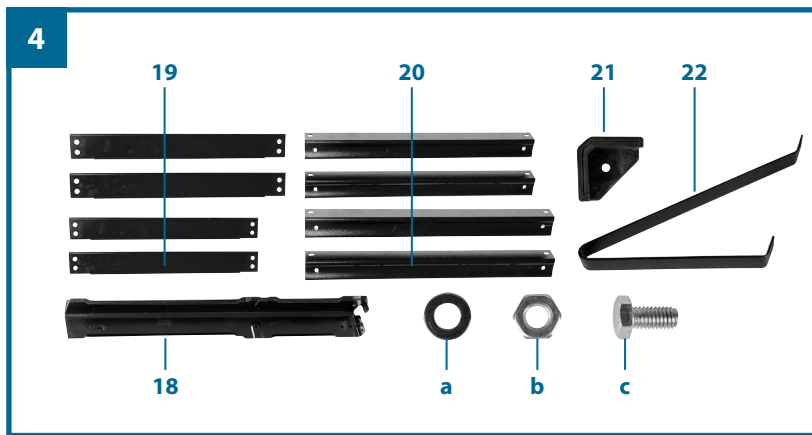

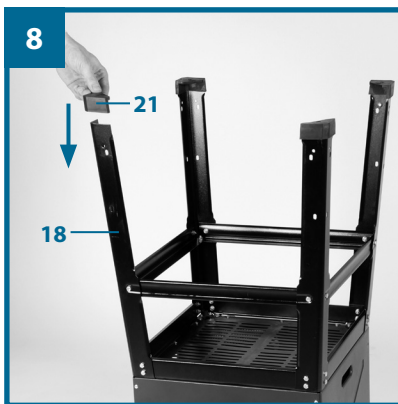
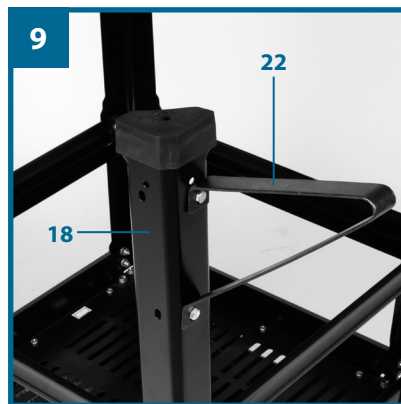
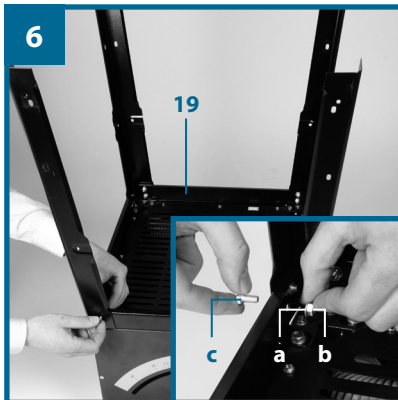
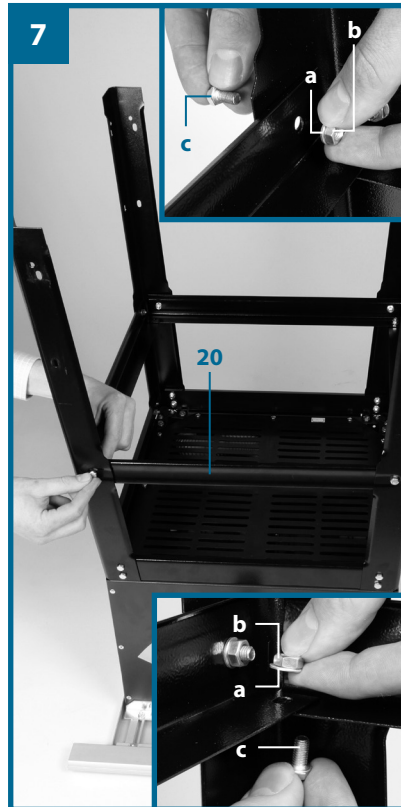
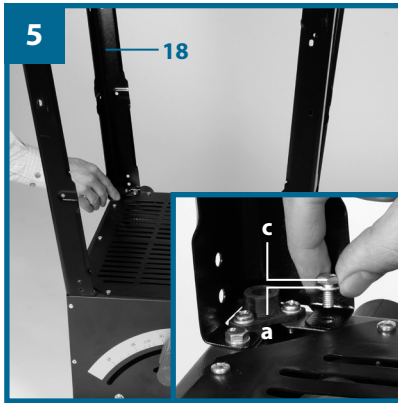

5.2 Fitting the table width extension and length extension (Fig. 10-14)

- Loosely fasten the table width extension and length extension (14/15) to the saw table (1) using the Allen screws (d) and the washers (e) so that the table width extension rests against the guide rail (Fig. 10-12).
- Screw the supports (23) loosely onto the saw housing and onto the table width extension or length extension (short supports for the width extension, long supports for the length extension) (Fig. 13-14)
- Align the table width extension and length extension level with the saw table (1).
- Finally, tighten all screws.
- Turn the saw together with the base frame and place on the floor.

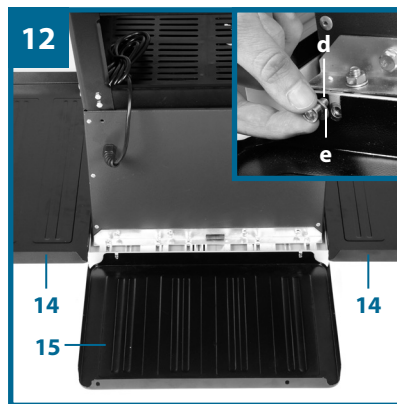
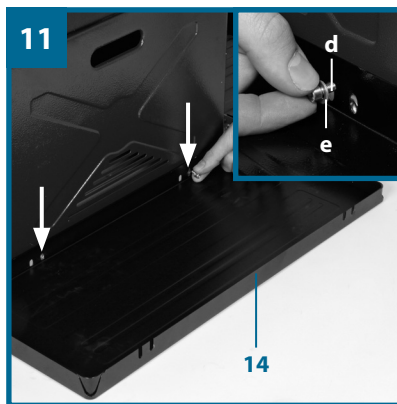
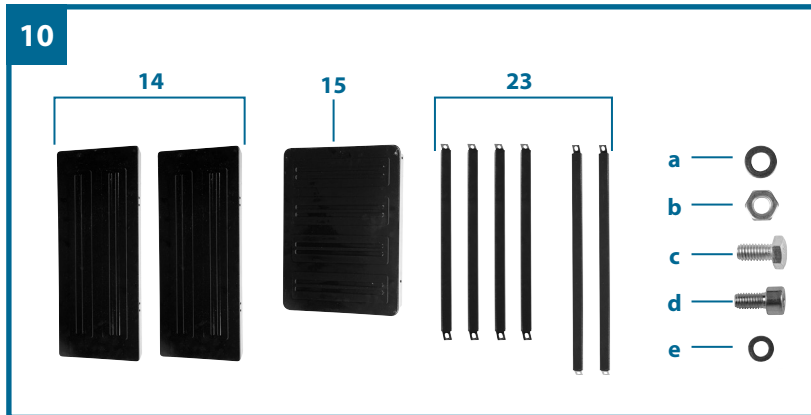

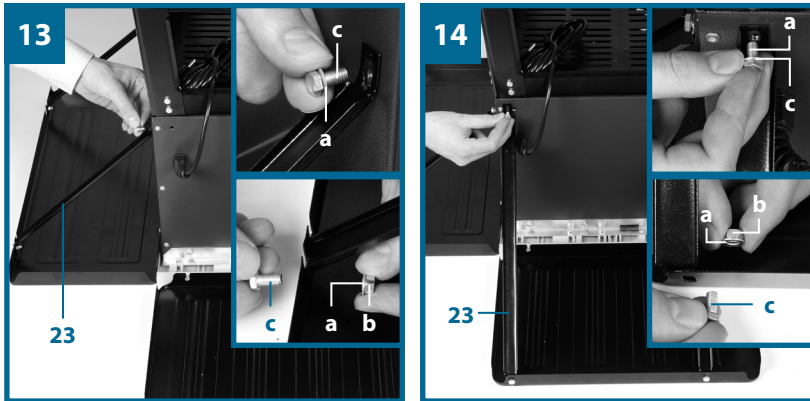

5.3 Fitting / removing the saw blade guard (Fig. 2, 15-16)

- When assembling the equipment for the first time, you must first fit and adjust the splitter. **To do so, proceed as described in Section 5.5.**
- Place the saw blade guard (2) together with the screw (24) on top of the splitter (4) so that the screw is snug in the oval hole (25).
- Do not tighten the screw (24) too far – the blade guard must be able to move freely.
- Fasten the extractor hose (3) to the extractor adapter (16) and to the extractor socket of the blade guard (2). Fasten the hose with the hose clip to the extractor adapter (16) (Fig. 2, 16). Connect a suitable chip extraction system to the extractor adapter (16).
- To dismantle, proceed in reverse order.

Important! The saw blade guard (2) must always be lowered over the workpiece before you begin to cut.

5.4 Changing the table insert (Fig. 17-18)

- To prevent increased likelihood of injury, the table insert should be changed whenever it is worn or damaged.
- Take off the saw blade guard (2) (see 5.3).
- Remove the 2 countersunk head screws (26).
- Take out the worn table insert (6).
- Fit the replacement table insert by following the above in reverse.

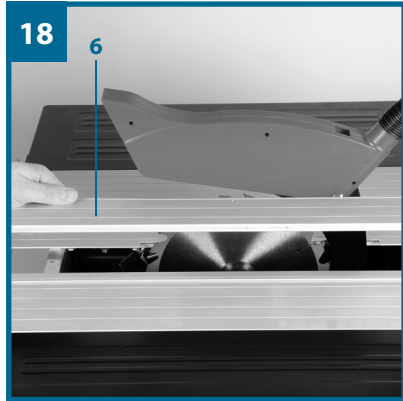
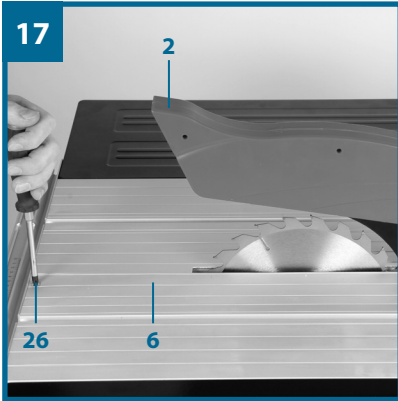
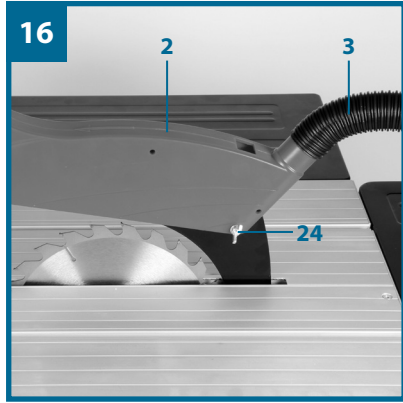
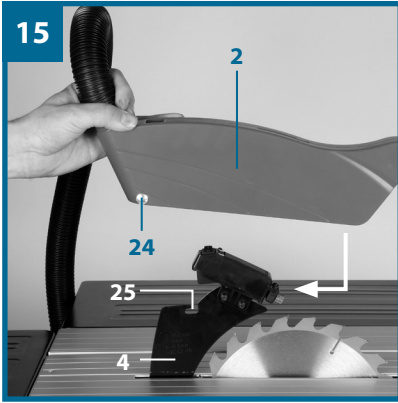

5.5 Adjusting the splitter (Fig. 19-20)

- **Caution! Pull out the power plug.**
- The setting of the saw blade has to be checked each time after changing the saw blade.
- Set the blade (5) to max. cutting depth, move to 0° position and lock in place (see 6.2).
- Remove the saw blade guard (see 5.3).
- Take out the table insert (6) (see 5.4).
- Slacken the fixing screw (27).
- Push up the splitter (4) up or down until the gap between the splitter (4) and the saw blade (5) is between 3 and 5 mm.
- The maximum gap of 5 mm must not be exceeded. (Fig. 20)
- Retighten the screw (27) and mount the table insert (6) (see 5.4).
- Remount the blade guard (2) (see 5.3).

5.6 Fitting/replacing the saw blade (Fig. 21)

- **Important! Pull out the power plug.**
- Dismantle the saw blade guard (2) (see 5.3).
- Remove the table insert by undoing the two countersunk head screws (see 5.4).
- Undo the nut with a size 24 wrench on the nut itself and a second fork wrench (size 10) on the drive shaft to apply counter-pressure.
- Important! Turn the nut in the direction of rotation of the saw blade.
- Take off the outer flange and pull the old saw blade off the inner flange by dropping the blade at an angle.
- Clean the saw blade flange thoroughly with a wire brush before fitting the new saw blade.
- Mount and fasten the new saw blade in reverse order.
- Important! Note the running direction. The cutting angle of the teeth must point in running direction, i.e. forwards (see the arrow on the blade guard).
- Refit and set the table insert (6) and the saw blade guard (2). (See 5.3, 5.4)
- Check to make sure that all safety devices are properly mounted and in good working condition before you begin working with the saw again.



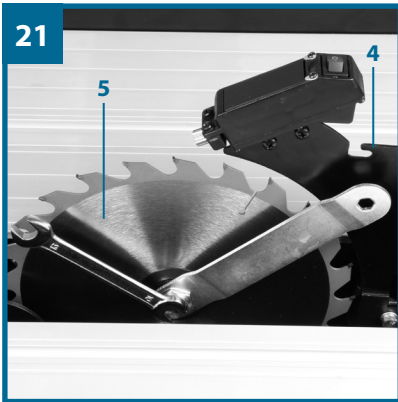
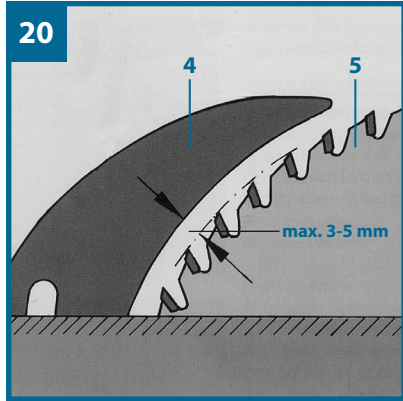
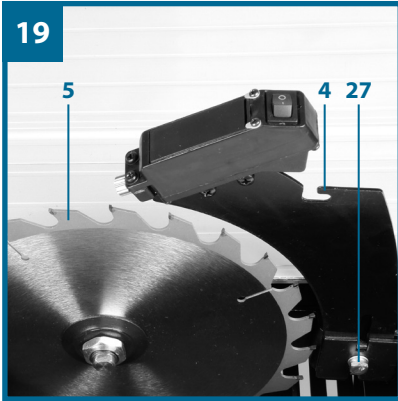

Operation

6

6.1. ON/OFF switch (Fig. 22)

- To turn the saw on, press the green button "I". Wait for the blade to reach its maximum speed of rotation before commencing with the cut.
- To turn the equipment off again, press the red button "0".

6.2. Cutting depth (Fig. 22)

Turn the hand crank (8) to set the blade (5) to the required cutting depth.

Turn anti-clockwise: larger cutting depth

Turn clockwise: smaller cutting depth

6.3. Setting the angle (Fig. 22)

- Undo the fixing handle (9).
- Turn the handle to set the desired angle on the scale.
- Lock the fixing handle again in the required angle position.

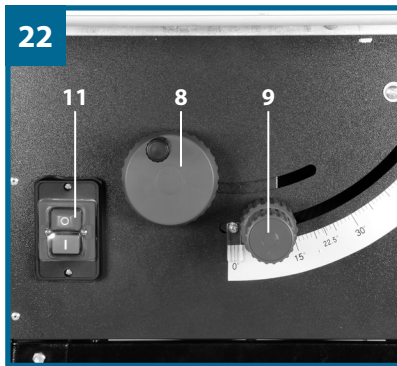

6.4 Parallel stop

6.4.1. Stop height (Fig. 23-26)

- The stop rail (e) for the parallel stop (7) has two different guide faces (high and low).
- For thick material you must use the stop rail (e) as shown in Fig. 25, for thin material (with a workpiece thickness of less than 25 mm) you must use the stop rail as shown in Fig. 26.

6.4.2. Turning the stop rail (Fig. 23-26)

- First undo the wing nuts (f) to turn the stop rail (e).
- The stop rail (e) can now be pulled off the guide rail (h) and can be pushed back over it with the appropriate guide.
- Retighten the wing nuts (f).

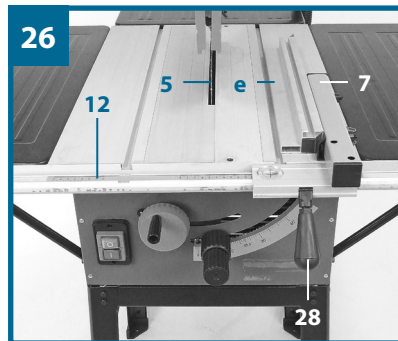
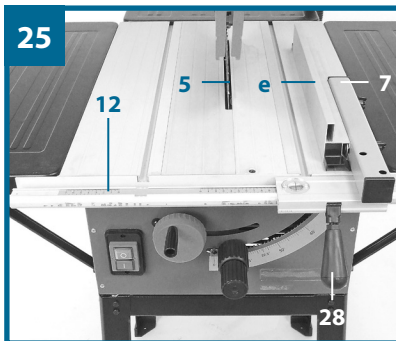
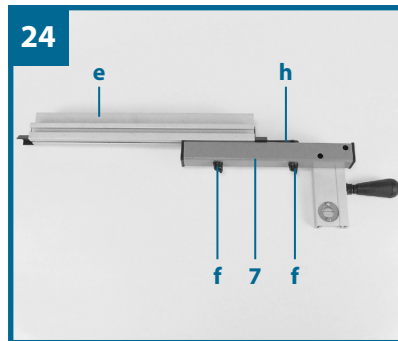
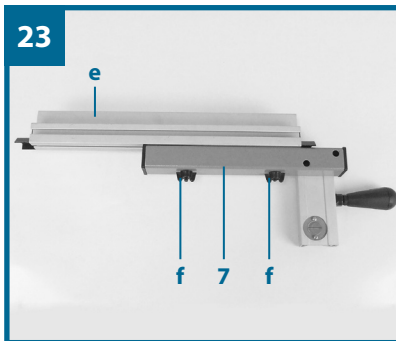

6.4.3 Cutting width (Fig. 26 - 28)

- The parallel stop (7) has to be used when making longitudinal cuts in wooden workpieces.
- The parallel stop (7) should be mounted on the right-hand side of the saw blade (5).
- Place the parallel stop (7) on the guide rail for the parallel stop (12) from above (Fig. 26).
- There are 2 scales (j/k) on the guide rail for the parallel stop (12) which show the distance between the stop rail (e) and the saw blade (5) (Fig. 27).
- Depending on this, choose the appropriate scale to suit whether the stop rail (e) is turned for thick or thin material:

High stop rail (thick material): Scale j

Low stop rail (thin material): Scale k

- Set the parallel stop (7) for the required dimension using the inspection window (l) and secure it using the eccentric lever for the parallel stop (28).

6.4.4 Adjusting the stop length (Fig. 29)

- Set the required cutting width.
- The stop rail (e) can be moved in longitudinal direction in order to prevent the workpiece from getting jammed.
- Rule of thumb: The rear end of the stop comes up against an imaginary line that begins roughly at the center of the blade and runs at an angle of 45° to the rear.
- Slacken the wing nuts (f) and push the stop rail (e) forward until it touches the imaginary 45° line.
- Tighten the wing nuts (f) again.



6.5 Adjusting the parallel stop (Fig. 30)

- Set the saw blade to the maximum cutting depth (refer to point 6.2).
- Set the parallel stop (7) so that the stop rail (e) touches the saw blade (5) (setting for thick material refer to point 6.4).
- If the parallel stop (7) is not in line with the saw blade (5), undo the screws (m) with an Allen key or similar until the parallel stop (7) can be adjusted parallel with the saw blade (5) (Fig. 30).
- Re-tighten the screws (m).

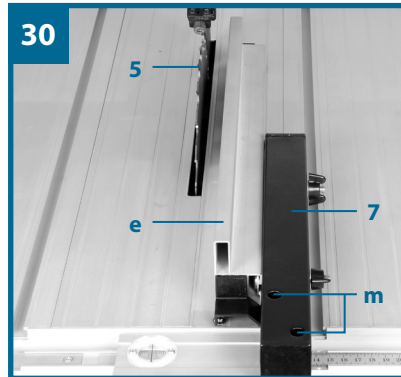
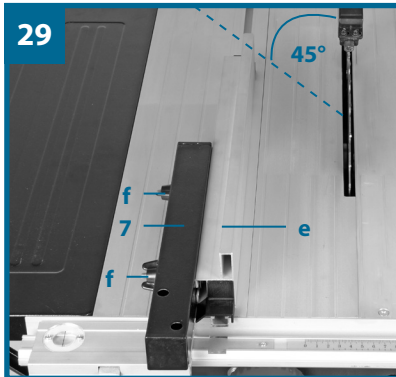
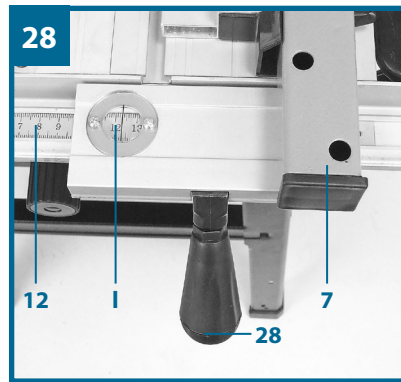
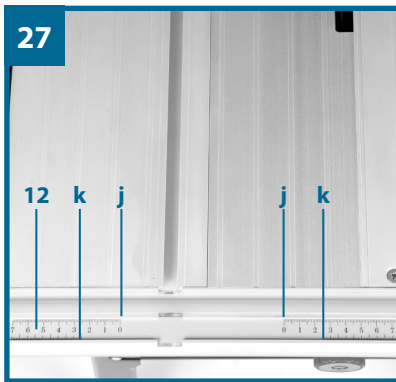

6.6 Cross stop (Fig. 31-32)

- Slide the cross stop (13) into the groove (29) of the table.
- Slacken the knurled screw (30).
- Turn the cross stop (13) until the arrow points to the angle required.
- Retighten the knurled screw (30).
- When cutting large parts of workpieces you can use the stop rail (e) from the parallel stop (7) to extend the length of the cross stop (13) (Fig. 32)
- To extend the cross stop (13) with the stop rail (e), the stop rail (e), the chain bar (h) and the wing nuts (f) must be removed together with the washers of the parallel stop (7). Now mount the stop rail as shown in Figure 32, using the lock bolts (n).

Important!

- Do not push the stop rail (e) too far toward the blade.
- The distance between the stop rail (e) and the blade (5) should be approx. 2 cm.

6.7 Adjusting the scale on the cross stop (Fig. 33)

- Place a 90° stop angle against the saw blade (5).
- Connect the cross stop (13) to the stop rail (e) of the parallel stop (7) (refer to point 6.6).
- Undo the knurled screw (30) of the cross stop (13).
- Position the cross stop (13) so that the stop rail (e) is in a 90° angle to the saw blade (5). Now precisely align the cross stop (13) to the saw blade (5) using the 90° stop angle and retighten the knurled screw (30).
- Check if the cross stop (13) is aligned at exactly 0°. If this is not the case, continue as follows:
- Undo the two screws (o) holding the scale (p) to the cross stop (13) until the scale can be set to the correct position.
- Retighten the screws (o).



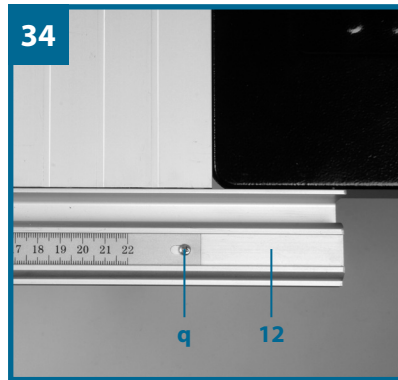
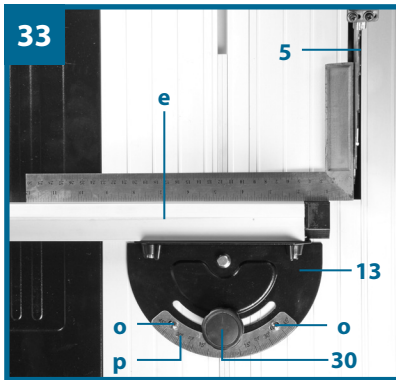
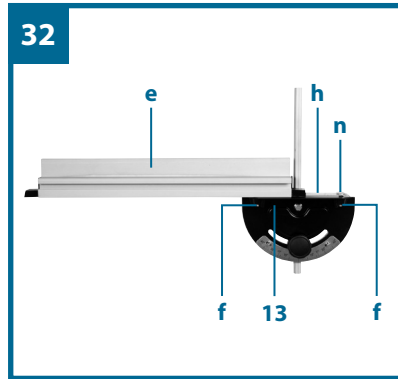
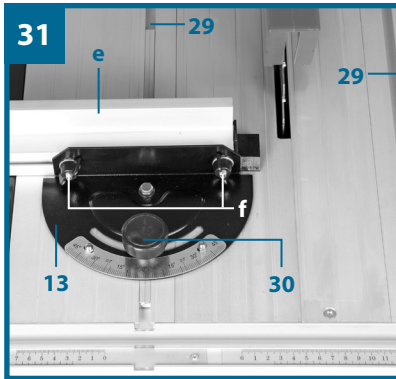

6.8 Adjusting the scale on the saw table (Fig. 28; 34)

- Ensure that the parallel stop (7) is in line with the saw blade (5) (refer to point 6.5).
- Set the parallel stop (7) so that it touches the saw blade (setting for thick material refer to point 6.4).
- Undo the screw (q) holding the scale (j/k) to the chain bar (12) by approximately 2 turns.
- Set the scale (j/k) so that the line in the inspection window (l) of the parallel stop (7) aligns with the zero line of the scale (j).
- Retighten the screw (q).

6.9 Using the laser (Fig. 35-38)

- The laser (31) enables you to make precision cuts with your table saw.
- The laser light is generated by a laser diode powered by two batteries (1.5V AA/LR03). The laser light is enlarged to form a line and is emitted through the laser emission aperture. You can then use the line as an optical marker of the sawing line for precision cuts. Follow the laser safety instructions.
- Inserting the batteries:
 - Remove the saw blade guard (2) (see 5.3). The laser is mounted on the splitter (4) and now easily accessible.
 - Set the laser ON/OFF switch (32) to position 0 (laser off).
 - Remove the battery compartment cover (34) by undoing the screws (33) and turning the mounting plates attached to the screw so that they no longer block the battery compartment cover (34). Now flip up the battery compartment cover (34).
 - Insert the batteries, ensuring that you fit them the right way around (see Figure 37).
 - Replace the battery compartment cover (34) and secure it with the screws (33).
- Refit the saw blade guard (2).
- Switching on the laser: Set the laser ON/OFF switch (32) to I. When the saw blade guard (2) is mounted you can easily access the laser ON/Off switch (32) through an opening provided in the saw blade guard. A red laser beam will now be projected from the laser emission aperture. If you guide the laser beam along the sawing line mark as you saw, you will produce clean, precise cuts.
- Switching off the laser: Set the laser ON/OFF switch (32) to 0. The laser beam will go out. Always switch off the laser when not in use in order to save the batteries.
- The laser beam can be blocked by deposits of dust and chips. You should therefore remove these particles from the laser emission aperture before you use the laser.
- Notes on batteries: If you do not intend to use the laser for a lengthy period of time, remove the batteries from the battery compartment. Any leakage of battery fluid might damage the tool.



- Do not place batteries on heaters or expose them to strong direct sunshine for long periods; temperatures above 50°C might damage the batteries.

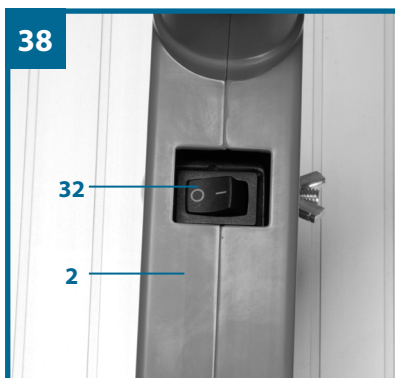
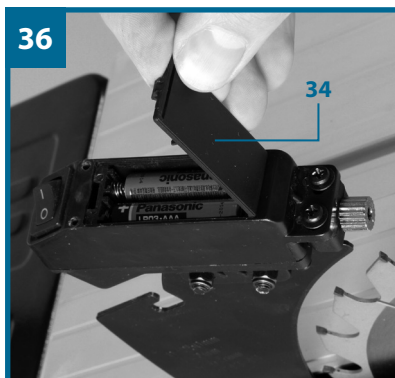
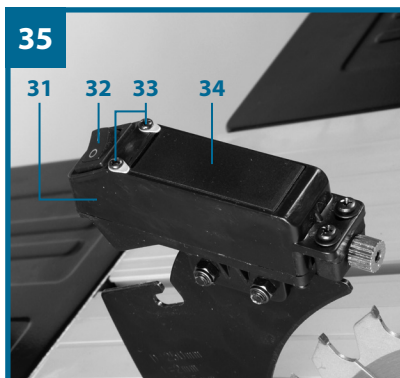

6.10 Operation

⚠ Important!

- After every new adjustment we recommend you to make a trial cut in order to check the new settings.
- After switching on the saw, wait for the blade to reach its maximum speed of rotation before commencing with the cut.
- Take extra care when starting the cut!
- Never use the equipment without the suction function.
- Regularly check and clean the suction channels.

6.10.1 Making longitudinal cuts (Fig. 39)

Longitudinal cutting (also known as slitting) is when you use the saw to cut along the grain of the wood. Press one edge of the workpiece against the parallel stop (7) while the flat side lies on the saw table (1).

The blade guard (2) must always be lowered over the workpiece. When making a longitudinal cut, never adopt a working position that is in line with the cutting direction.

- Set the parallel stop (7) in accordance with the workpiece height and the desired width. (See 6.4.)
- Switch on the saw.
- Place your hands flat on the workpiece and push the workpiece along the parallel stop (7) and into the blade (5).
- Guide at the side with your left or right hand (depending on the position of the parallel stop) only as far as the front edge of the saw blade guard (2).
- Always push the workpiece through to the end of the splitter (4).
- The offcut piece remains on the saw table (1) until the blade (5) is back in its resting position.
- Secure long workpieces against falling off at the end of the cut (e.g. with a roller stand etc.).

6.10.11 Cutting narrow workpieces (Fig. 40)

Be sure to use a push stick (17) when making longitudinal cuts in workpieces smaller than 120 mm in width. A push stick is supplied with the saw! Replace a worn or damaged push stick immediately.



6.10.1.2 Cutting very narrow workpieces (Fig. 41)

- Be sure to use a push block when making longitudinal cuts in very narrow workpieces with a width of 30 mm and less.
- The low guide face of the parallel stop is best used in this case.
- There is no push block supplied with the saw! (Available from your specialist dealer)
- Replace the push block without delay when it becomes worn.

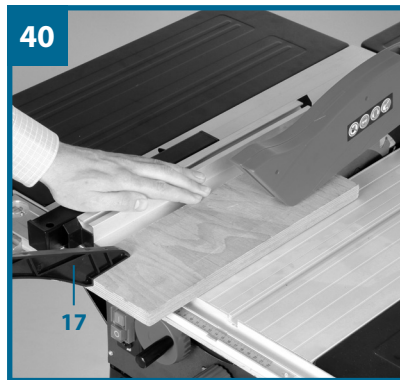
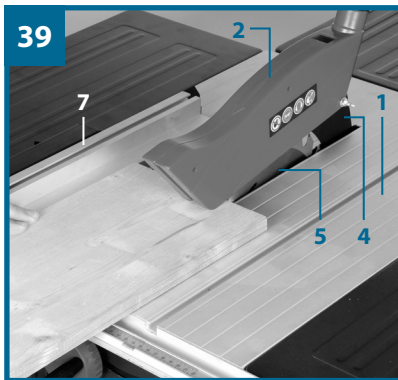

6.10.1.3 Making angular cuts (Fig. 42)

Angular cuts must always be made using the parallel stop (7).

- Set the blade (5) to the desired angle. (See 8.3.)
- Set the parallel stop (7) in accordance with the workpiece width and height (see 6.4)
- Carry out the cut in accordance with the workpiece width (see 6.10.1.1 and 6.10.1.2).

6.10.2 Making cross cuts (Fig. 43)

- Slide the cross stop (13) into one of the grooves (29) in the table and adjust to the required angle (see 6.6). If you also want to tilt the blade (5), use the groove (29) which prevents your hand and the cross stop from making contact with the blade guard.
- If necessary, use the stop rail (e).
- Press the workpiece firmly against the cross stop (13).
- Switch on the saw.
- Push the cross stop (13) and the workpiece toward the blade in order to make the cut.
- **⚠ Important:**
Always hold the guided part of the workpiece. Never hold the part which is to be cut off.
- Push the cross stop (13) forward until the workpiece is cut all the way through.
- Switch off the saw again. Do not remove the offcut until the blade has stopped rotating.

6.10.3 Cutting particle boards

To prevent the cutting edges from cracking when working with particle boards, you should not set the saw blade (5) more than 5mm higher than the thickness of the workpiece (refer to point 6.2).



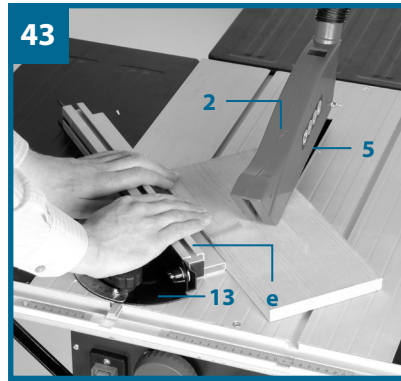
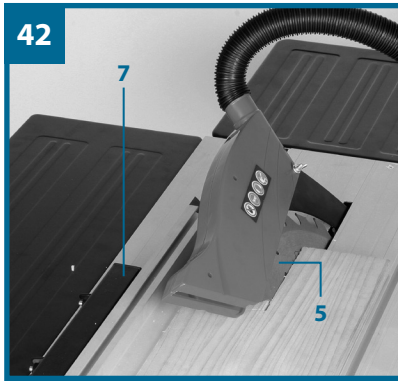

Technical data

AC motor	230-240 V ~ 50 Hz
Power P	S6 40% 1700 W
Idle speed n_0	6,500 min ⁻¹
Carbide saw blade Ø 250 x Ø 30 x 2.4 mm	24 teeth
Carbide saw blade Ø 250 x Ø 30 x 3.0 mm	48 teeth
Table size	610 x 445 mm
Table width extension, left/right	608 x 250 mm
Table length extension, rear	435 x 320 mm
Max. cutting height	72 mm / 90°
.....	54 mm / 45°
Height adjustment	infinite 0 - 72 mm
Tilting saw blade	infinite 0° - 45°
Dust extraction connector	Ø 36 mm
Net weight	approx. 24.5 kg

Operating mode S6: Continuous operation

To prevent the motor from overheating, only use the bench-type circular saw as follows:

After an operating period of 4 minutes (S 6 = 40%) under the permitted load, you must interrupt your work for a period of 6 minutes in which the machine can run idle.

Noise emission values

The noise emission values were measured in accordance with EN 61029-2-1.

	On-load operation
L_{pA} sound pressure level	94 dB(A)
K_{pA} uncertainty	3 dB
L_{WA} sound power level	105 dB(A)
K_{WA} uncertainty	3 dB

Wear ear-muffs.

The impact of noise can cause damage to hearing.

The quoted values are emission values and not necessarily reliable workplace values. Although there is a correlation between emission and immission levels it is impossible to draw any certain conclusions as to the need for additional precautions. Factors with a potential influence on the actual immission level at the workplace include the duration of impact, the type of room, and other sources of noise etc., e.g. the number of machines and other neighboring operations. Reliable workplace values may also vary from country to country. With this information the user should at least be able to make a better assessment of the dangers and risks involved.

Reduce noise generation and vibration to a minimum!

- Use only equipment that is in perfect condition.
- Maintain and clean the equipment regularly.
- Adapt your way of working to the equipment.
- Do not overload the equipment.
- Have the equipment checked if necessary.
- Switch off the equipment when not in use.

Replacing the power cable

If the power cable for this equipment is damaged, it must be replaced by the manufacturer's after-sales service or by similarly trained personnel to avoid danger.



Cleaning and maintenance

Important! Always pull out the power plug before starting any cleaning work.

Cleaning

- Keep the safety devices free of dirt and dust as far as possible. Wipe the equipment with a clean cloth or blow it down with compressed air at low pressure.
- We recommend that you clean the equipment immediately after you use it.
- Clean the equipment regularly with a damp cloth and some soft soap. Do not use cleaning agents or solvents; these may be too harsh and can corrode the plastic parts in the equipment. Ensure that no water can get into the interior of the equipment.

Carbon brushes

In case of excessive sparking, have the carbon brushes checked by a qualified electrician. Caution! Only a qualified electrician is allowed to replace the carbon brushes.

Disposal and recycling

The equipment is supplied in packaging to prevent it from being damaged in transit. The raw materials in this packaging can be reused or recycled. The equipment and its accessories are made of various types of material, such as metal and plastic. Defective components must be disposed of as special waste. Contact your manufacturer or your local council for further information.



Disposing of batteries

Batteries contain materials that are potentially harmful to the environment. Never place batteries in your household refuse, in fire or in water. Batteries should be collected, recycled or disposed of by environment-friendly means. Please contact your local council for further information.

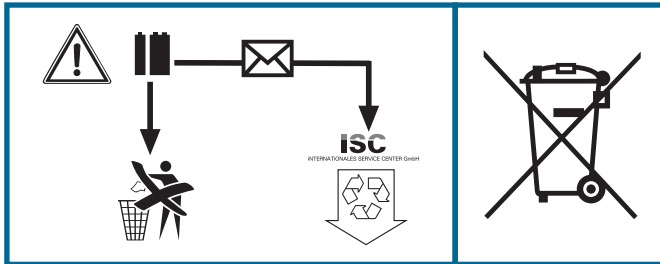

Ordering spare parts

Contact our After Sales Support on 1300 922 271 and provide the following information on all orders for spare parts:

- Type of unit
- Article number of the unit
- ID number of the unit
- Spare part number of the required spare part





Never place electric power tools in your household waste!

Instead of returning the equipment to the manufacturer, the owner of the electrical equipment is obliged to ensure that the equipment is properly disposed of if relinquishing ownership. The old equipment can be returned to a suitable collection point that will dispose of the equipment in accordance with the national recycling and waste disposal regulations. This does not apply to any accessories or aids without electrical components supplied with the old equipment.

The reprinting or reproduction by any other means, in whole or in part, of documentation and papers accompanying products is permitted only with the express consent of the ISC GmbH.

Subject to technical changes.



Guarantee Certificate **8**

09/2013

Congratulations!

You have made an excellent choice of this quality product. Our commitment to quality also includes our service. Should you, contrary to expectations, experience defects due to manufacturing faults, ALDI will provide you with a warranty against defects as follows:

Warranty

The product is guaranteed to be free from defects in workmanship and parts for a period of 36 months from the date of purchase. Defects that occur within this warranty period, under normal use and care, will be repaired, replaced or refunded at our discretion. The benefits conferred by this warranty are in addition to all rights and remedies in respect of the product that the consumer has under the Competition and Consumer Act 2010 and similar state and territory laws. Our goods come with guarantees that cannot be excluded under the Australian Consumer Law. You are entitled to a replacement or refund for a major failure and for compensation for any other reasonably foreseeable loss or damage. You are also entitled to have the goods repaired or replaced if the goods fail to be of acceptable quality and the failure does not amount to a major failure.

Proof of Purchase

This warranty is valid for the original purchase and is not transferable. Please keep your purchase docket, tax invoice or receipt as the best proof of purchase, and as proof of date on which the purchase was made.

Extent of Warranty

This warranty is limited to defects in workmanship or parts. All defective products or parts will be repaired or replaced. This warranty does not cover batteries or any other consumable items.

Normal Wear and Tear

This warranty does not cover normal wear and tear to the products or parts.

Exclusions

This warranty does not cover:

- Any defects caused by an accident, misuse, abuse, improper installation or operation, lack of reasonable care, unauthorised modification, loss of parts, tampering or attempted repair by a person not authorised by the distributor.
- Any product that has not been installed, operated or maintained in accordance with the manufacturer's operating instructions provided with the product.
- Any product that has been used for purposes other than domestic use.
- Any damage caused by improper power input or improper cable connection.

To Make a Claim

This warranty against defects is provided by ALDI Stores, Locked Bag 56, St Marys Delivery Centre, NSW 2760, Phone (02) 9675 9000. If a defect in the goods appears within 36 months you are entitled to claim a warranty, please contact or send all warranty claims to:

Einhell Australia Pty. Ltd.

6/166 Wellington Street, Collingwood, VIC 3066, Australia

Telephone: 1300 922 271 (Operating Hours: Mon-Fri 8:30am to 5:30pm EST)

Email: service.australia@einhell.com

When making a return, please ensure the product is properly packaged so as to ensure that no damage occurs to the product during transit.

Please provide the original or a copy of the proof of purchase. Also please make sure you have included an explanation of the problem.

Please note upon receiving your warranty claim, the supplier will send, via the post or email, a repair and refurbished goods or parts notice. Please provide your email address and advise the supplier, if you wish to obtain a repair and refurbished goods or parts notice via email.

EH 05/2013 (01)