

Original Operating Instructions
Universal Crosscut Saw

Einhell®

7

Art.-Nr.: 43.007.91

I.-Nr.: 11010



RT-XM **305**



Ⓜ Read and follow the operating instructions and safety information before using the equipment for the first time.

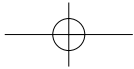
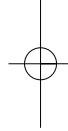
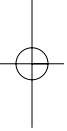

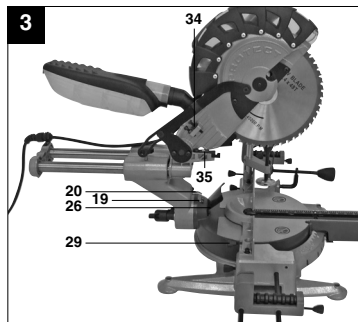
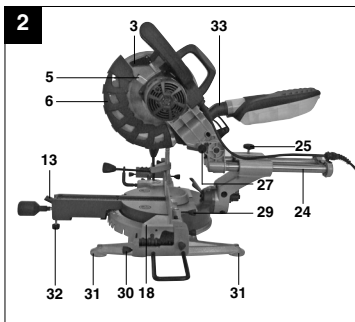
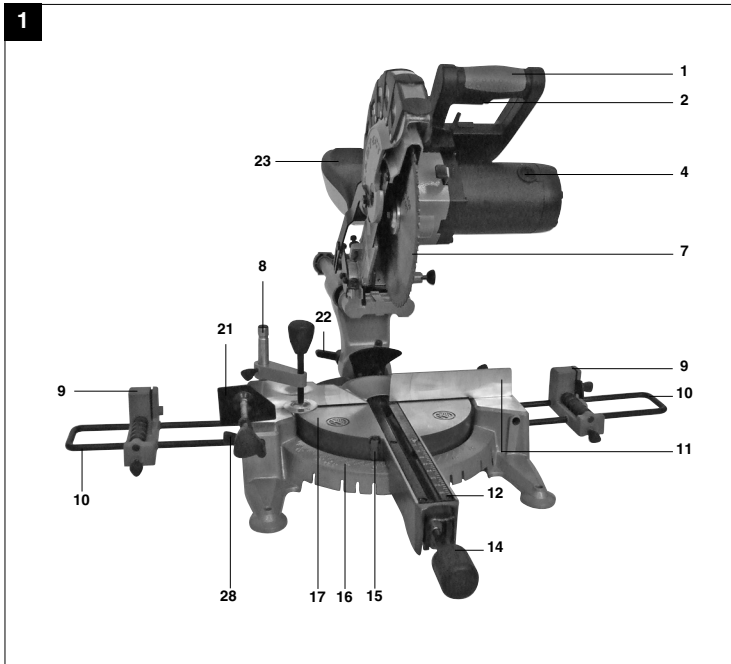

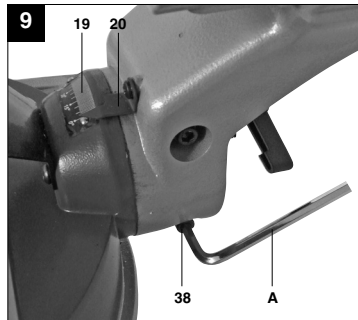
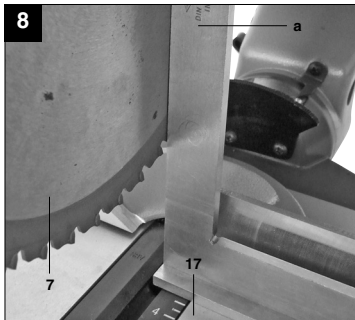
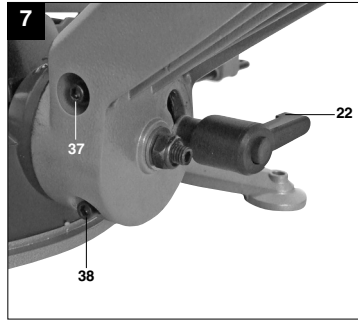
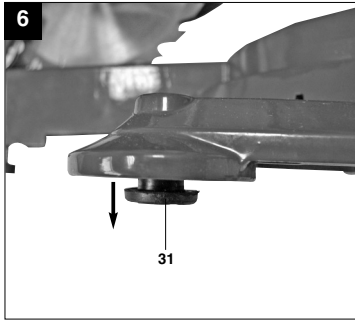
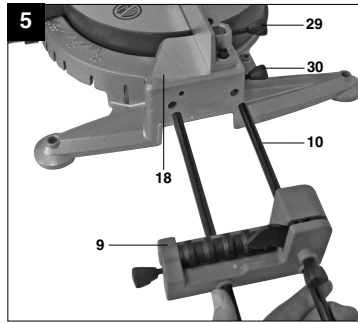
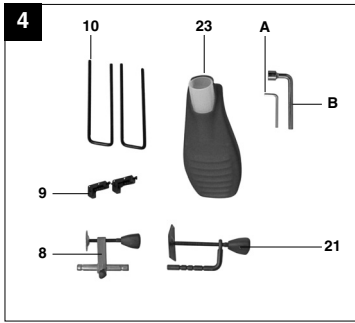

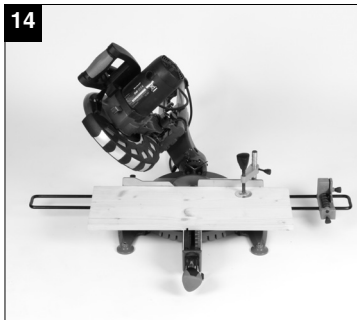
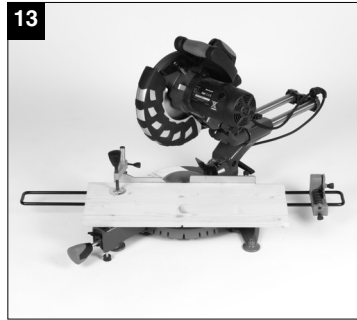
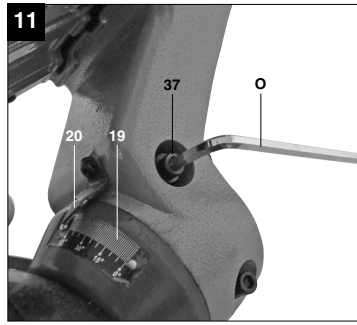
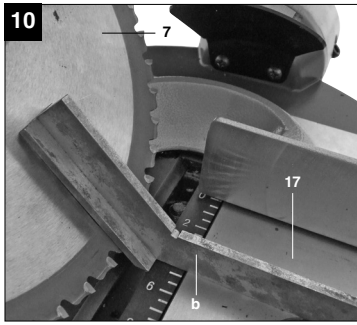

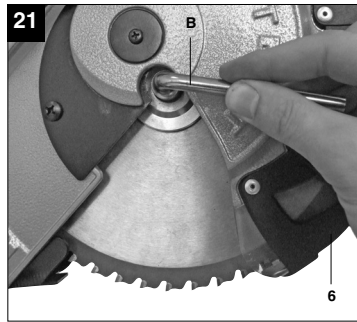
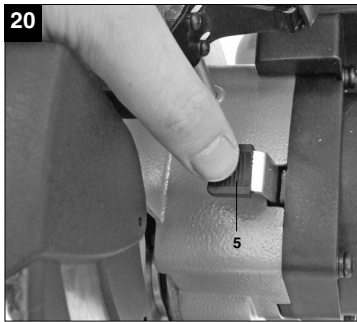
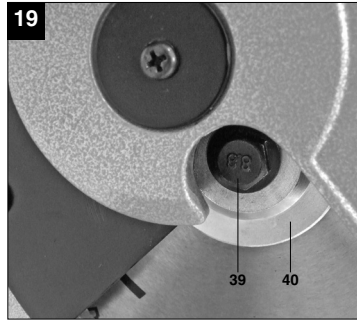
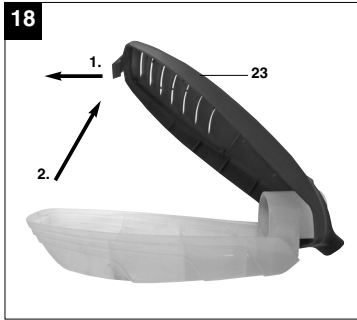
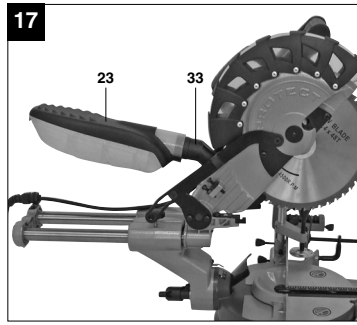
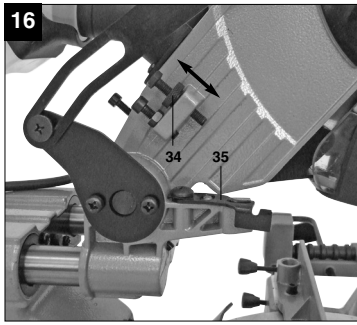

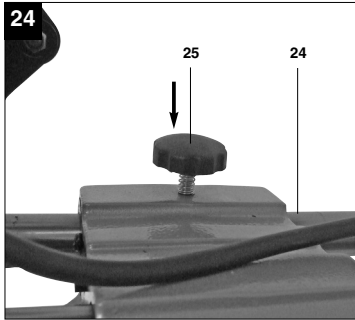
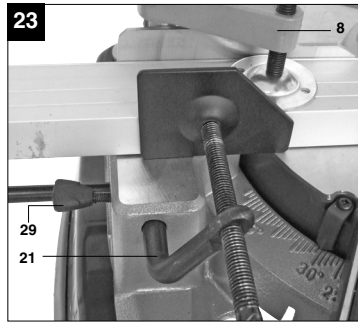
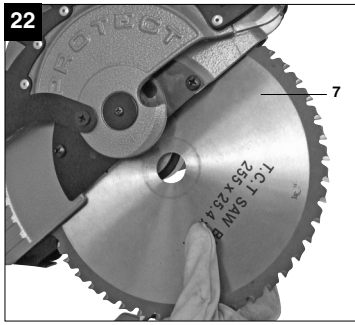



Table of contents:

	Page
1. Safety Information	9
2. Layout	9
3. Items supplied	9
4. Intended use	9 - 10
5. Technical data	10 - 11
6. Before starting the equipment	11
7. Operation as wood/plastics saw	11 - 13
8. Operation as metal saw	13
9. Transport	13
10. Replacing the power cable	13
11. Cleaning, maintenance and ordering of spare parts	13 - 14
12. Disposal and recycling	14

⚠ Important.

When using the equipment, a few safety precautions must be observed to avoid injuries and damage. Please read the complete operating instructions and safety information with due care. Keep this manual in a safe place so that the information is available at all times. If you give the equipment to any other person, hand over these operating instructions and the safety information as well. We cannot accept any liability for damage or accidents which arise due to a failure to follow these instructions and the safety information.

1. Safety Information

Please refer to the booklet included in delivery for the safety information.

⚠ CAUTION

Read all the safety information and instructions. Any errors made in following the safety regulations and instructions may result in an electric shock, fire and/or serious injury.

Keep all safety regulations and instructions in a safe place for future use.

2. Layout**2.1 Drag, crosscut and miter saw (Fig. 1-3)**

1. Handle
2. ON/OFF switch
3. Release lever
4. Machine head
5. Saw shaft lock
6. Movable blade guard
7. Saw blade
8. Vertical clamping device
9. Roll base with limit stop
10. Holding bar for the roll base
11. Stop rail
12. Table insert with cutting depth scale
13. Latched position lever
14. Locking grip
15. Pointer
16. Scale
17. Turntable
18. Fixed saw table
19. Scale
20. Pointer
21. Horizontal clamping device
22. Locking screw
23. Chip box
24. Drag guide
25. Locking screw for drag guide

26. Guard
27. Fastening bolt
28. Locking screw for the horizontal clamping device
29. Locking screw for the vertical clamping device
30. Locking screw for the roll base
31. Foot with rubber stopper
32. Foot
33. Extractor adapter
34. Knurled screw for cutting depth limiter
35. Stop for cutting depth limiter

3. Items supplied (Fig. 1, 4)

- Drag, crosscut and miter Saw
- Clamping device (8)
- Roll base with limit stop (9)
- 2 x Holding bar for the roll base (10)
- Chip box (23)
- Allen key (A)
- Allen key (B)

4. Intended use

The universal saw is designed for cross-cutting wood and plastic. In accordance with the operating instructions the equipment can also be used to saw hollow metal profiles with a rectangular cross-section. Sawing metal profiles may only be carried out with crosscuts. The equipment is expressly not permitted to saw metal with a tensile strength of more than 400 N/mm², hardened metal, combustible and reactive metals (such as magnesium and magnesium alloys), all kinds of round materials and firewood.

The equipment is to be used only for its prescribed purpose. Any other use is deemed to be a case of misuse.

The user / operator and not the manufacturer will be liable for any damage or injuries of any kind caused as a result of this.

Please note that our equipment has not been designed for use in commercial, trade or industrial applications. Our warranty will be voided if the equipment is used in commercial, trade or industrial businesses or for equivalent purposes.

The equipment is to be operated only with suitable saw blades. It is prohibited to use any type of cutting-off wheel.

To use the equipment properly you must also observe the safety regulations, the assembly instructions and the operating instructions to be found in this manual.

GB

All persons who use and service the equipment have to be acquainted with this manual and must be informed about the machine's potential hazards. It is also imperative to observe the accident prevention regulations in force in your area. The same applies for the general rules of health and safety at work.

The manufacturer will not be liable for any changes made to the equipment nor for any damage resulting from such changes. Even when the equipment is used as prescribed it is still impossible to eliminate certain residual risk factors. The following hazards may arise in connection with the machine's construction and design:

- Contact with the saw blade in the uncovered saw zone.
- Reaching into the running saw blade (cut injuries).
- Kick-back of workpieces and parts of workpieces.
- Saw blade fracturing.
- Cataapulting of faulty carbide tips from the saw blade.
- Damage to hearing if ear-muffs are not used as necessary.
- Harmful emissions of metal and wood dust when used in closed rooms.
- Cut injuries through contact with chips and workpieces.
- Eye injuries caused by small metal chips.

5. Technical data

AC motor:	240V ~ 50Hz
Power:	1800 W
Operating mode:	S1
Idle speed n_0 :	2,500 min ⁻¹
Carbide saw blade:	ø 250 x ø 30 x 2.2 mm
Number of teeth:	48
Swiveling range:	-52° / 0° / +60°
Miter cut:	0° to 45° to the left
Saw width at 90°:	
Wood:	305 x 75 mm
Metal:	105 x 75 mm
Saw width at 45°:	
Wood:	210 x 75 mm
Metal:	70 x 75 mm
Saw width at 2 x 45° (double miter cut):	
Wood:	210 x 40 mm
Metal:	70 x 40 mm
Weight:	approx. 17.5 kg

Sound and vibration

Sound and vibration values were measured in accordance with EN 61029.

L_{pA} sound pressure level	93.7 dB(A)
K_{pA} uncertainty	3 dB
L_{WA} sound power level	108.5 dB(A)
K_{WA} uncertainty	3 dB

Wear ear-muffs.

The impact of noise can cause damage to hearing.

Total vibration values (vector sum of three directions) determined in accordance with EN 61029.

Vibration emission value $a_h = 1.068 \text{ m/s}^2$

K uncertainty = 1.5 m/s²

Warning!

The specified vibration value was established in accordance with a standardized testing method. It may change according to how the electric equipment is used and may exceed the specified value in exceptional circumstances.

The specified vibration value can be used to compare the equipment with other electric power tools.

The specified vibration value can be used for initial assessment of a harmful effect.

Keep the noise emissions and vibrations to a minimum.

- Only use appliances which are in perfect working order.
- Service and clean the appliance regularly.
- Adapt your working style to suit the appliance.
- Do not overload the appliance.
- Have the appliance serviced whenever necessary.
- Switch the appliance off when it is not in use.

Residual risks

Even if you use this electric power tool in accordance with instructions, certain residual risks cannot be ruled out. The following hazards may arise in connection with the equipment's construction and layout:

1. Lung damage if no suitable protective dust mask is used.
2. Damage to hearing if no suitable ear protection is used.
3. Health damage caused by hand-arm vibrations if



the equipment is used over a prolonged period or is not properly guided and maintained.

6. Before starting the equipment

6.1 General information

- Before commissioning the machine, it must be firmly mounted on a workbench or similar. For this pull the four rubber stoppers (32) from the bottom side of the saw (Figure 6) and insert 4 screws through the feets to fix it on a stable surface.
- All covers and safety devices have to be properly fitted before the machine is switched on.
- It must be possible for the blade to run freely.
- When working with wood that has been processed before, watch out for foreign bodies such as nails or screws, etc.
- Before you actuate the On/Off switch, make sure that the saw blade is correctly fitted and that the machine's moving parts run smoothly.
- Check that the voltage on the rating plate is the same as your supply voltage before you connect the machine to the power supply.

6.2 Assembling the saw (Fig. 1-3; 5)

- To adjust the turntable (17), loosen the locking grip (14) by approx. 2 turns, which frees the turntable (17).
- Press the latched position lever (13), turn the turntable (17) and scale pointer (15) to the desired angular setting on the dial (16) and lock into place with the locking grip (14). The saw has locking positions at angles of -45° , -30° , -22.5° , -15° , 0° , 15° , 22.5° , 30° , 45° and 60° , at which you can engage the latched position lever.
- To release the saw from its position at the bottom, pull the fastening bolt (27) out of the motor mounting while pressing down lightly on the machine head (4). Turn the fastening bolt (27) through 90° before releasing it, so that the saw remains unlocked.
- Swing the machine head (4) up until the release lever (3) latches into place.
- The clamping devices (8, 21) can be fitted on the left or right of the fixed saw table (18).
- Undo the locking screws for the roll base (30).
- Guide roll base with limit stop (9) over one of the holding bars for the roll base (10) and install on the fixed saw table (18), tightening the appropriate locking screw (30) (Figure 5).
- Mount the second holding bar for the roll base (10) on the opposite side of the saw and secure with the appropriate locking screw (30).
- When the locking screw (22) is loosened, you can

tilt the machine head (4) to the left by up to 45° .

- The foot (32) will prevent the saw from tipping forwards during operation. Turn out the foot (32) until it touches the surface on which the saw is standing.

6.3 Precision adjustment of the stop for crosscut 90° (Fig. 1, 7-9)

- Fasten the turntable (17) in 0° position.
- Undo the locking screw (22) and move the machine head (4) all the way to the right using the handle (1).
- Place the 90° angular stop (a) between the blade (7) and the turntable (17).
- Adjust the adjustment screw (38) until the angle between the blade (7) and the turntable (17) equals 90° .
- Finally, check the position of the pointer (20) on the scale (19). If necessary, release the pointer (20) with a crosstip screwdriver, move to the 0° position of the scale (19) and retighten the holding screw.
- **No stop angle included.**

6.4 Precision adjustment of the stop for miter cut 45° (Fig. 1, 25, 10, 11)

- Fasten the turntable (17) in 0° position.
- Undo the locking screw (22) and move the machine head (4) all the way to the left using the handle (1), until it coincides at 45° .
- Place the 45° stop angle (b) between the blade (7) and the turntable (17).
- Adjust the adjustment screw (37) so that the angle between the blade (7) and the turntable (17) equals exactly 45° .
- **No stop angle included.**

7. Operation as wood/plastics saw

7.1 Cross cut 90° and turntable 0° (Fig. 1-3, 12)

For cutting widths up to approx. 100 mm it is possible to fix the saw's drag function with the locking screw for drag guide (25) in rear position. If the cutting width exceeds 100 mm you must ensure that the locking screw for drag guide (25) is slackened and that the machine head (4) can be moved.

- Move the machine head (4) to its upper position.
- Use the handle (1) to push back the machine head (4) and fix it in this position if required (dependent on the cutting width).
- Place the piece of wood to be cut at the stop rail (11) and on the turntable (17).
- Lock the material with the clamping device (8) on the fixed saw table (18) to prevent the material from moving during the cutting operation.

GB

- Push down the release lever (3) to release the machine head (4).
- Press the ON/OFF switch (2) to start the motor.
- With the drag guide (24) fixed in place: Use the handle (1) to move the machine head (4) steadily and with light pressure downwards until the saw blade (7) has completely cut through the workpiece.
- With the drag guide (24) not fixed in place: Pull the machine head (4) all the way to the front and then use the handle (1) to move it downwards steadily and with light pressure. Now push the machine head (4) slowly and steadily to the very back until the saw blade (7) has completely cut through the workpiece.
- When the cutting operation is completed, move the machine head (4) back to its upper (home) position and release the ON/OFF button (2).

Important. The integral resetting springs will automatically lift the machine head. Do not simply let go of the handle (1) after cutting, but allow the machine head (4) to rise slowly, applying slight counterpressure as it does so.

7.2 Cross cut 90° and turntable -52°...+60° (Fig. 1-3, 13)

The crosscut saw can be used to make crosscuts of 0° - 52° to the left and 0° - 60° to the right in relation to the stop rail.

- Release the turntable (17) by slackening the locking grip (14).
- Press the latched position lever (13), turn the turntable (17) and scale pointer (15) to the desired angular setting on the dial (16) and lock into place with the locking grip (14). The saw has locking positions at angles of -45°, -30°, -22.5°, -15°, 0°, 15°, 22.5°, 30°, 45° and 60°, at which you can engage latched position lever.
- Retighten the locking grip (14) to secure the turntable (17) in place.
- Cut as described under section 7.1.

7.3 Miter cut 0° - 45° and turntable 0° (Fig. 1-3, 14)

The crosscut saw can be used to make miter cuts of 0° - 45° in relation to the work face.

- If necessary, dismantle the clamping device (8) or mount it on the opposite side of the fixed saw table (18).
- Move the machine head (4) to its upper position.
- Fasten the turntable (17) in 0° position.
- Undo the locking screw (22) and use the handle (1) to tilt the machine head (4) to the left until the pointer (20) coincides with the required value on the scale (19).
- Retighten the locking screw (22) and make the cut as described in section 7.1.

7.4 Miter cut 0° - 45° and turntable 0° - 45° (Fig. 1-3, 15)

The crosscut saw can be used to make miter cuts to the left of 0° - 45° in relation to the work face and, at the same time, 0° - 52° to the left or 0° - 60° to the right in relation to the stop rail (double miter cut).

- If required, dismantle the clamping device (8) or mount on the opposite side of the fixed saw table (18).
- Move the machine head (4) to its upper position.
- Release the turntable (17) by slackening the locking grip (14).
- Use the handle (1) to adjust the turntable (17) to the angle required (in this connection see also section 7.2).
- Retighten the locking grip (14) to secure the turntable in place.
- Undo the locking screw (22) and use the handle (1) to tilt the machine head (4) to the left until it coincides with the required angle value (in this connection see also section 7.3).
- Re-tighten the fixing screw (22).
- Cut as described under section 7.1.

7.5 Limiting the cutting depth (Fig. 16)

- The cutting depth can be infinitely adjusted using the screw (34). To do so, undo the knurled nut on the screw (34) and move the stop for the cutting depth limiter (35) to the outside. Turn the screw (34) in or out to set the required cutting depth and then retighten the knurled nut on the screw (34).
- Check the setting by completing a test cut.

7.6 Chip box (Fig. 17, 18/Item 23)

The saw is equipped with a chip box (23) for sawdust and chips. The chip box (23) can be fitted onto the extractor adapter (33).

To empty the chip box (23), flip the box open as shown in Figure 36 and carefully empty it by tapping.

Alternatively, a suitable dust extraction device can be fitted to the extractor adaptor (33).

7.7 Changing the saw blade (Fig. 1, 19-22)

Pull out the power plug!

- Swing the machine head (4) upwards and lock in this position with the fastening bolt (27).
- Press the release lever (3) and swing up the saw blade guard (6) to the point where the recess in the saw blade guard (6) is above the flange bolt (39).
- Press the saw shaft lock (5) with one hand while holding the wrench (B) on the flange bolt (39) with the other.
- Firmly press on the saw shaft lock (5) and slowly

rotate the flange bolt (39) in clockwise direction. The saw shaft lock (5) engages after no more than one rotation.

- Now, using a little more force, slacken the flange bolt (39) in the clockwise direction.
- Turn the flange screw (39) right out and remove the external flange (40).
- Take the blade (7) off the inner flange and pull out downwards.
- Carefully clean the flange screw (39), outer flange (40) and inner flange.
- Fit and fasten the new saw blade (7) in reverse order.
- **Important.** The cutting angle of the teeth, in other words the direction of rotation of the saw blade (7) must coincide with the direction of the arrow on the housing.
- Check to make sure that all safety devices are properly mounted and in good working condition before you begin working with the saw again.
- **Important.** Every time that you change the saw blade, check to see that it spins freely in the table insert (12) in both perpendicular and 45° angle settings.
- **Important.** The work to change and align the saw blade (7) must be carried out correctly.

8. Operation as metal saw

Important. Wear gloves (risk of injury) and suitable safety goggles.

- You can make crosscuts with and without miter in the angle ranges listed in section 7.) When working with metal, you can only make crosscuts due to risk of kick-back. In this case the drag guide (24) must be fixed with the locking screw (Figure 24).
- Before using the equipment, sweep any small metal chips away from the machine to protect yourself against injury. Always clamp the workpiece with the vertical clamping device (8) and the horizontal clamping device (21) (Figure 23).
- Press the ON/OFF switch (2). Wait until the saw blade reaches full speed before making a cut.
- Press the release lever (3). With the drag guide (24) fixed in place, use the handle (1) to move the machine head (4) downwards steadily, quickly and exerting slight pressure until the workpiece is completely cut through.
- When the cutting operation is completed, move the machine head (4) back to its upper (home) position and release the ON/OFF button (2).
- Let the saw blade run to a complete stop before removing the workpiece.

- **Important:** The integral resetting springs will automatically lift the machine head. Do not simply let go of the handle (1) after cutting but allow the machine head (4) to rise slowly, applying slight counterpressure as it does so.

9. Transport (Fig. 1-3)

- Retighten the locking grip (14) to secure the turntable (17) in place.
- Activate the release lever (3), press the machine head (4) downwards and secure with the fastening bolt (27). The saw is now locked in its bottom position.
- Fix the saw's drag function with the locking screw for the drag guide (25) in the rear position.
- Carry the machine on the fixed saw table (18).
- To set up the equipment again, proceed as described in section 6.2.

10. Replacing the power cable

If the power cable for this equipment is damaged, it must be replaced by the manufacturer or its after-sales service or similarly trained personnel to avoid danger.

11. Cleaning, maintenance and ordering of spare parts

Always pull out the mains power plug before starting any cleaning work.

11.1 Cleaning

- Keep all safety devices, air vents and the motor housing free of dirt and dust as far as possible. Wipe the equipment with a clean cloth or blow it down with compressed air at low pressure.
- We recommend that you clean the equipment immediately after you use it.
- Clean the appliance regularly with a damp cloth and some soft soap. Do not use cleaning agents or solvents; these may be aggressive to the plastic parts in the appliance. Ensure that no water can get into the interior of the equipment.

11.2 Carbon brushes

In case of excessive sparking, have the carbon brushes checked only by a qualified electrician. **Important.** The carbon brushes should not be replaced by anyone but a qualified electrician.



11.3 Servicing

There are no parts inside the equipment which require additional maintenance.

11.4 Ordering replacement parts:

Please provide the following information on all orders for spare parts:

- Model/type of the equipment
- Article number of the equipment
- ID number of the equipment
- Spare part number of the required spare part

For our latest prices and information please go to www.isc-gmbh.info

12. Disposal and recycling

The equipment is supplied in packaging to prevent it from being damaged in transit. The raw materials in this packaging can be reused or recycled.

The equipment and its accessories are made of various types of material, such as metal and plastic. Defective components must be disposed of as special waste. Ask your dealer or your local council.



- Ⓢ Never place any electric tools in your household refuse.
Seek advice on correct disposal from local waste authorities.



©
The reprinting or reproduction by any other means, in whole or in part,
of documentation and papers accompanying products is permitted only
with the express consent of ISC GmbH.

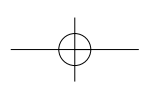
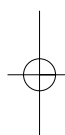
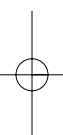



Ⓢ Technical changes subject to change



GUARANTEE CERTIFICATE

Dear Customer,

All of our products undergo strict quality checks to ensure that they reach you in perfect condition. In the unlikely event that your device develops a fault, please contact our service department at the address shown on this guarantee card. Of course, if you would prefer to call us then we are also happy to offer our assistance under the service number printed below. Please note the following terms under which guarantee claims can be made:

1. These guarantee terms cover additional guarantee rights and do not affect your statutory warranty rights. We do not charge you for this guarantee.
2. Our guarantee only covers problems caused by material or manufacturing defects, and it is restricted to the rectification of these defects or replacement of the device. Please note that our devices have not been designed for use in commercial, trade or industrial applications. Consequently, the guarantee is invalidated if the equipment is used in commercial, trade or industrial applications or for other equivalent activities. The following are also excluded from our guarantee: compensation for transport damage, damage caused by failure to comply with the installation/assembly instructions or damage caused by unprofessional installation, failure to comply with the operating instructions (e.g. connection to the wrong mains voltage or current type), misuse or inappropriate use (such as overloading of the device or use of non-approved tools or accessories), failure to comply with the maintenance and safety regulations, ingress of foreign bodies into the device (e.g. sand, stones or dust), effects of force or external influences (e.g. damage caused by the device being dropped) and normal wear resulting from proper operation of the device.

The guarantee is rendered null and void if any attempt is made to tamper with the device.
3. The guarantee is valid for a period of 2 years starting from the purchase date of the device. Guarantee claims should be submitted before the end of the guarantee period within two weeks of the defect being noticed. No guarantee claims will be accepted after the end of the guarantee period. The original guarantee period remains applicable to the device even if repairs are carried out or parts are replaced. In such cases, the work performed or parts fitted will not result in an extension of the guarantee period, and no new guarantee will become active for the work performed or parts fitted. This also applies when an on-site service is used.
4. In order to assert your guarantee claim, please send your defective device postage-free to the address shown below. Please enclose either the original or a copy of your sales receipt or another dated proof of purchase. Please keep your sales receipt in a safe place, as it is your proof of purchase. It would help us if you could describe the nature of the problem in as much detail as possible. If the defect is covered by our guarantee then your device will either be repaired immediately and returned to you, or we will send you a new device.

Of course, we are also happy offer a chargeable repair service for any defects which are not covered by the scope of this guarantee or for units which are no longer covered. To take advantage of this service, please send the device to our service address.

EINHELL AUSTRALIA PTY LTD
6/166 Wellington Street
Collingwood VIC 3066
Australia
Phone: 1300 922 271



EH 06/2010 (01)

