

Einhell®

7



Art.-Nr.: 34.153.10

I.-Nr.: 01017

BG-GC 80

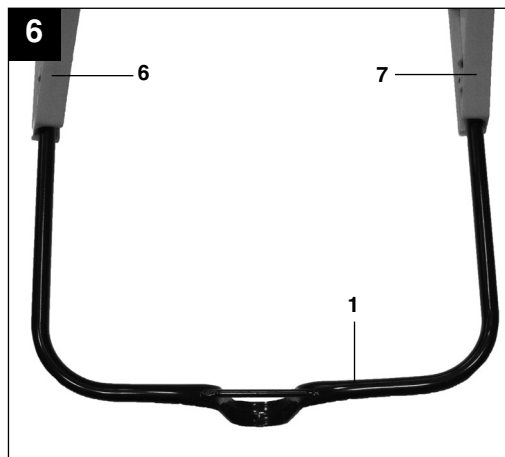
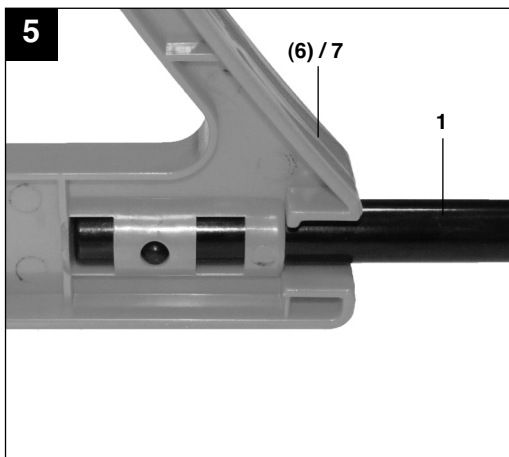
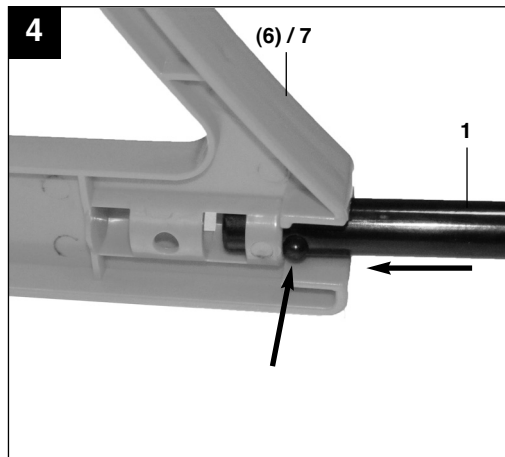
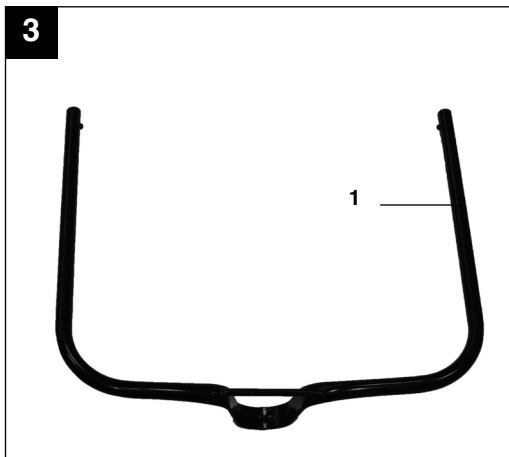
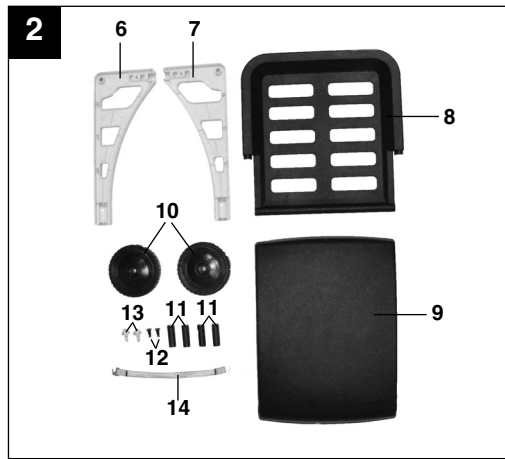
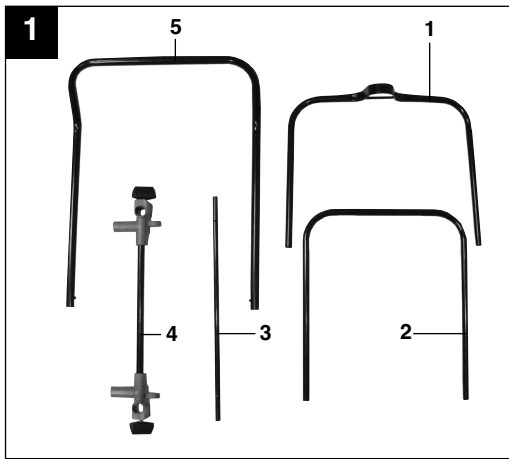

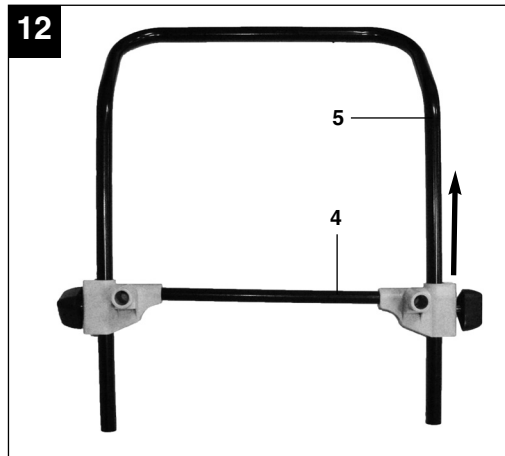
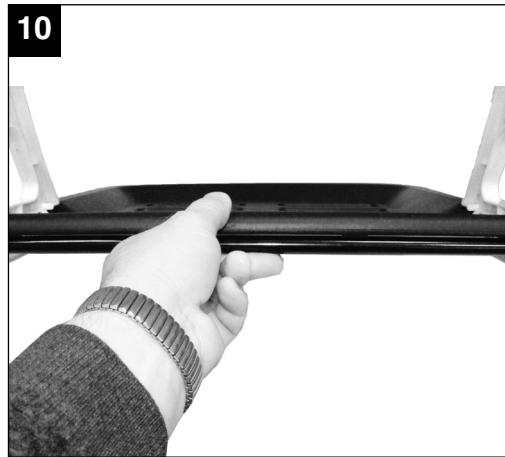
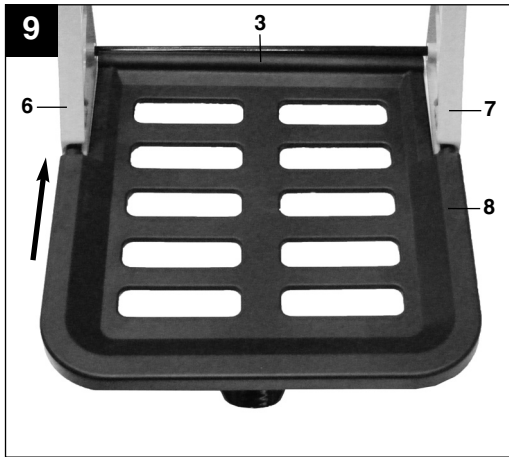
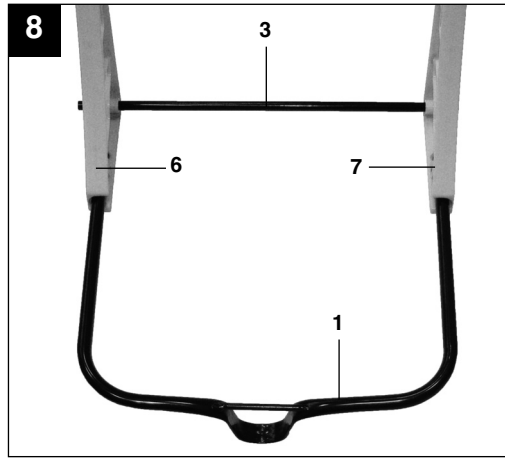
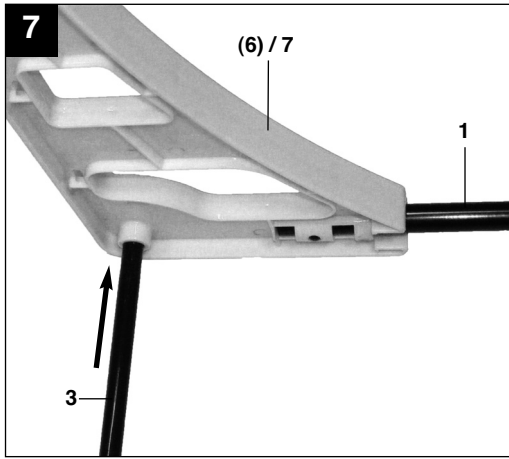

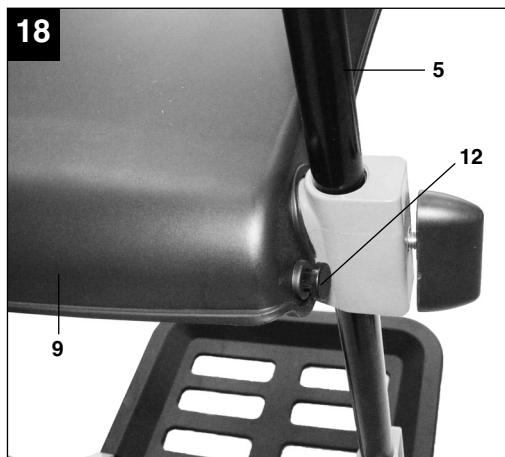
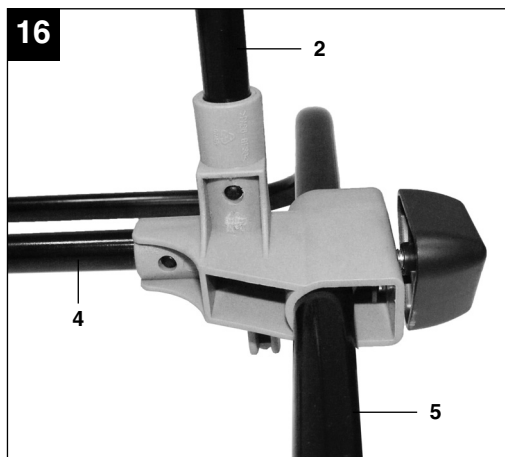
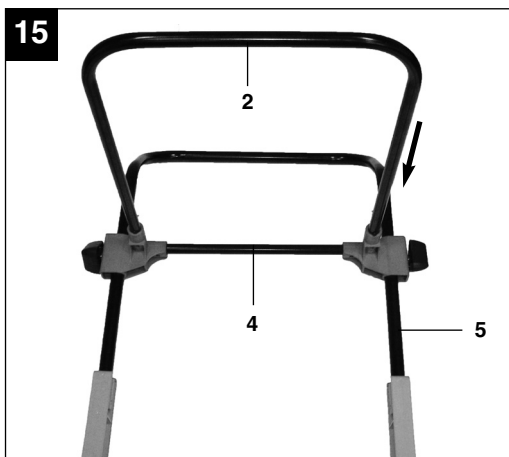
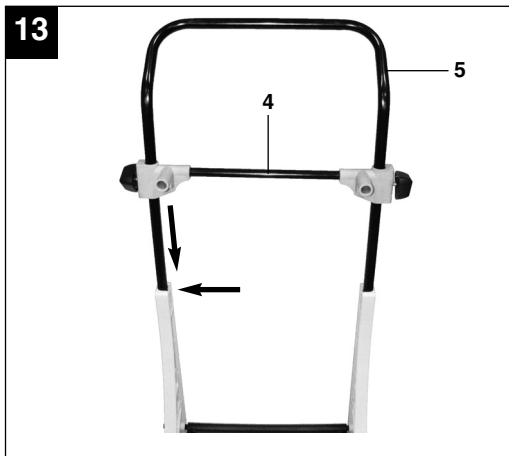

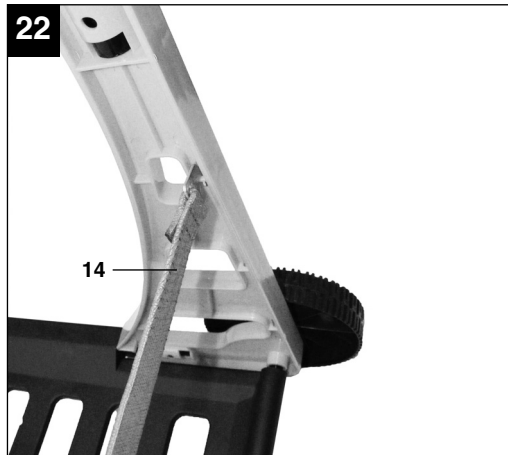
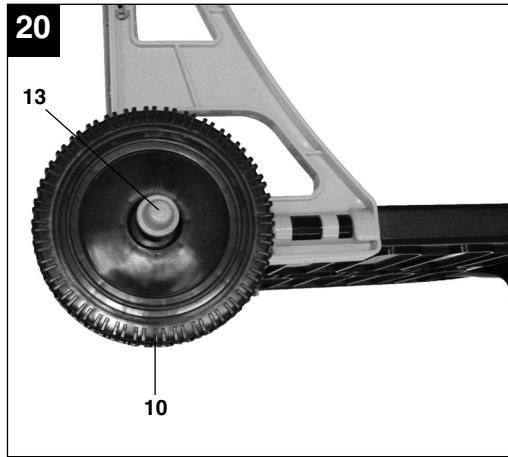
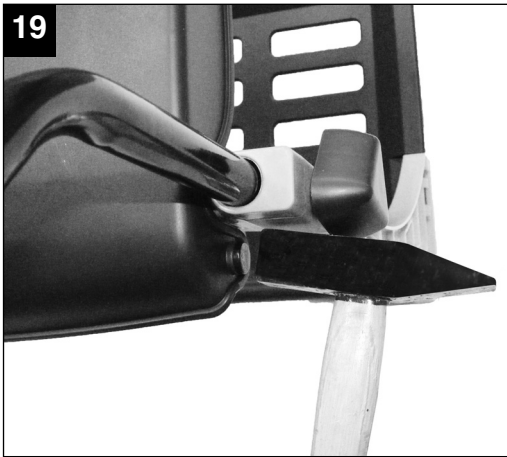



1 Service Hotline: 01 805 120 509 · www.isc-gmbh.info
(0,14 € / min., Festnetz T-Com) · Mo-Fr: 8:00-20:00 Uhr

2 Name: Retouren-Nr. iSC:

Straße / Nr.: Telefon:

PLZ Ort Mobil:

3 Welcher Fehler ist aufgetreten (genaue Angabe): Art.-Nr.: I.-Nr.:

Sehr geehrte Kundin, sehr geehrter Kunde,
bitte beschreiben Sie uns die von Ihnen festgestellte Fehlfunktion Ihres Gerätes als Grund Ihrer Beanstandung möglichst genau. Dadurch können wir für Sie Ihre Reklamation schneller bearbeiten und Ihnen schneller helfen. Eine zu ungenaue Beschreibung mit Begriffen wie „Gerät funktioniert nicht“ oder „Gerät defekt“ verzögert hingegen die Bearbeitung erheblich.

4 Garantie: JA NEIN Kaufbeleg-Nr. / Datum:

1 Service Hotline kontaktieren oder bei iSC-Webadresse anmelden - es wird Ihnen eine Retourennummer zugeteilt | **2** Ihre Anschrift eintragen | **3** Fehlerbeschreibung und Art.-Nr. und I.-Nr. angeben | **4** Garantiefall JA/NEIN ankreuzen sowie Kaufbeleg-Nr. und Datum angeben und eine Kopie des Kaufbeleges beilegen