

© GB **Operating Instructions**
Drag, Crosscut and Miter Saw

Einhell®

7

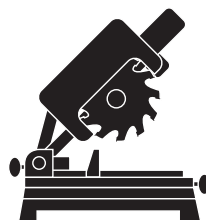

Art.-Nr.: 43.006.56

I.-Nr.: 01018

RT-SM 330 U



Ⓞ Read and follow the operating instructions and safety information before using for the first time.

1

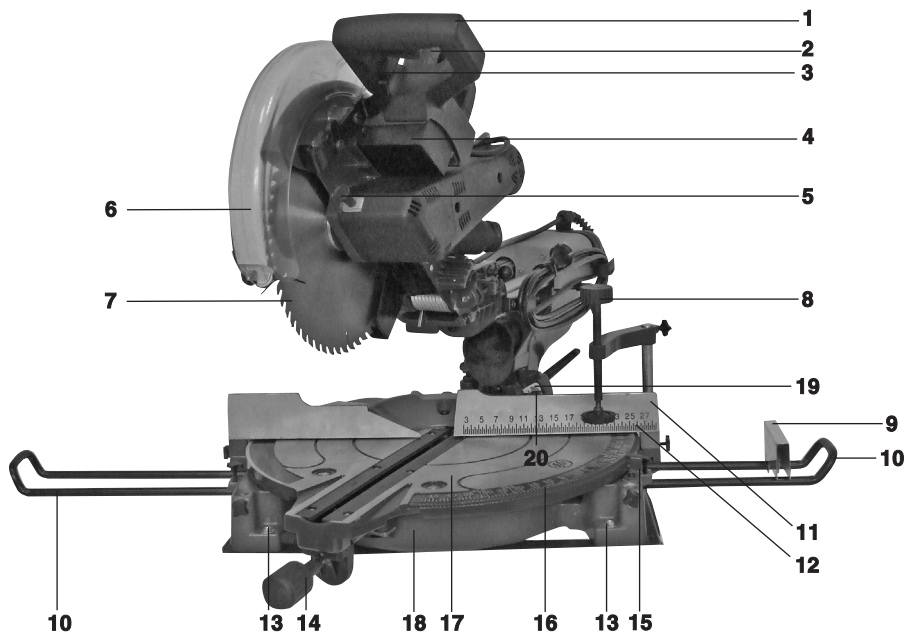

2

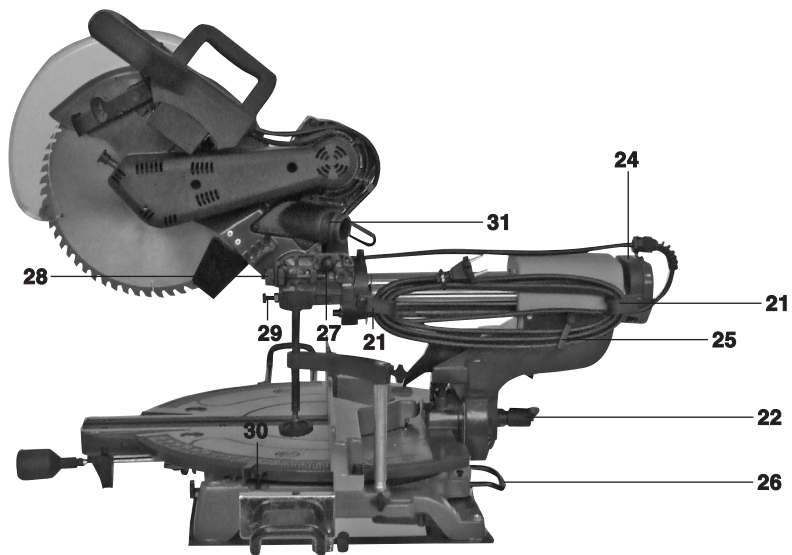

3

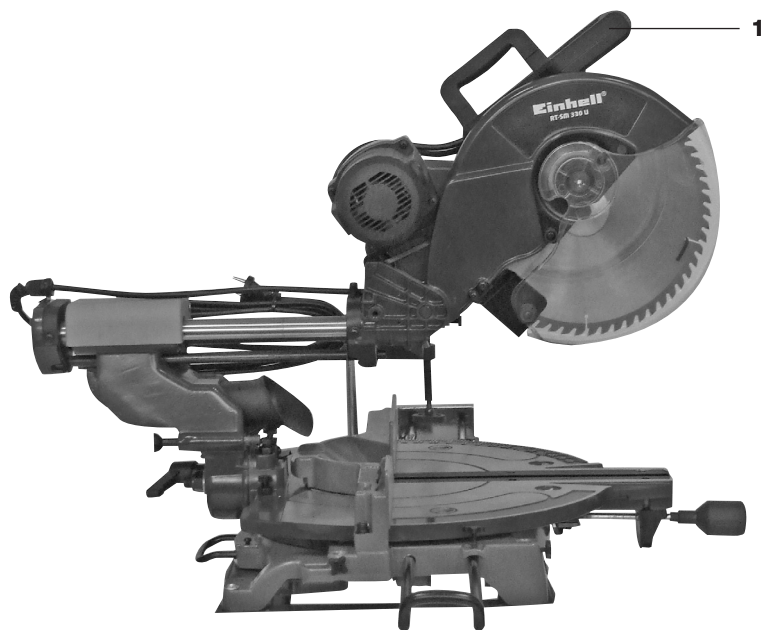

4

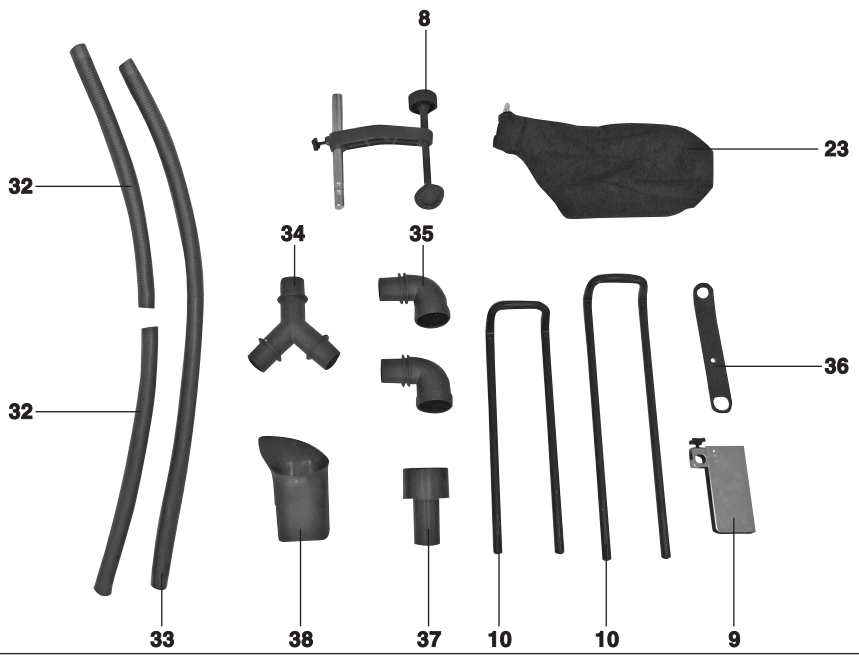

4

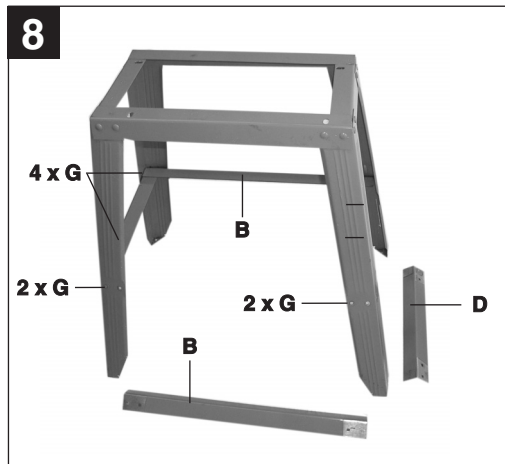
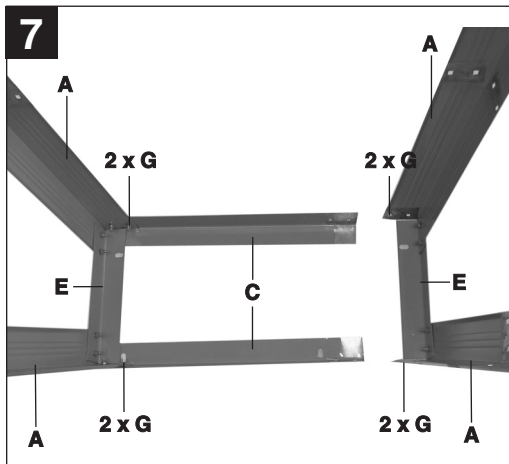
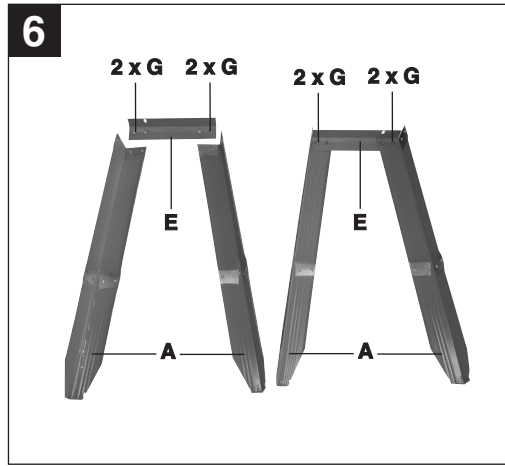
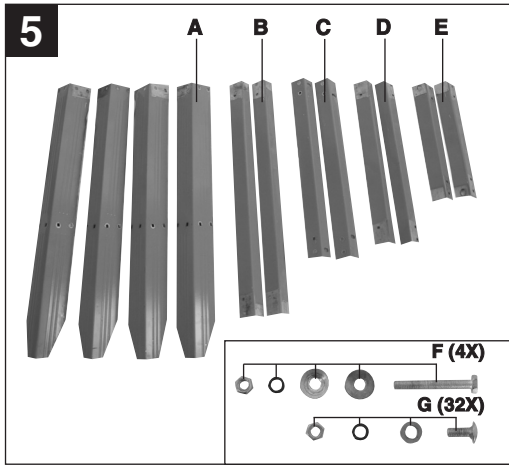

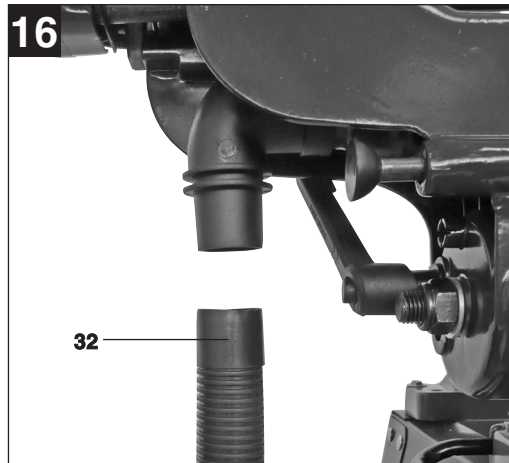
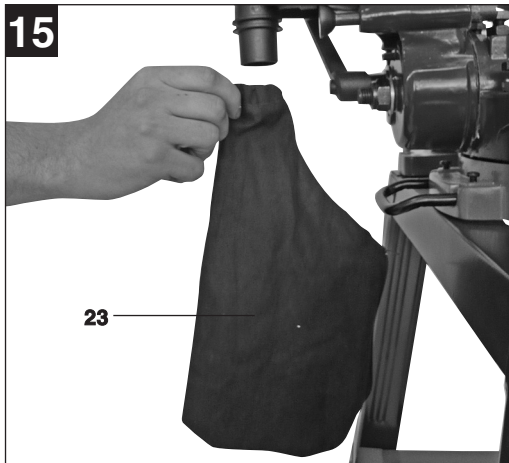
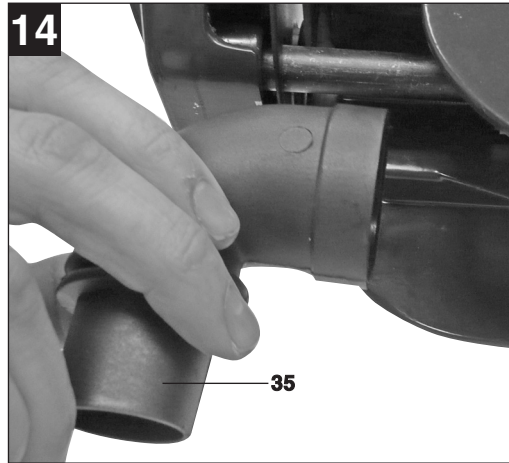
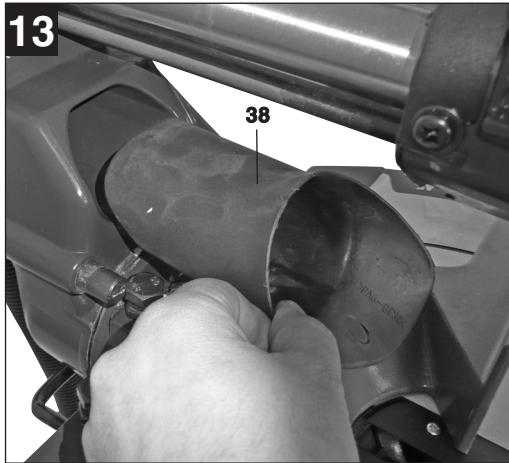
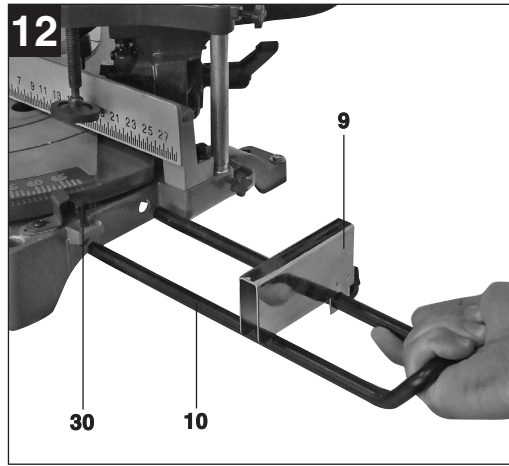
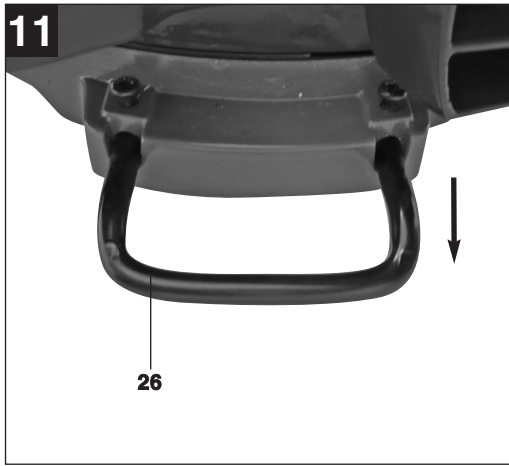

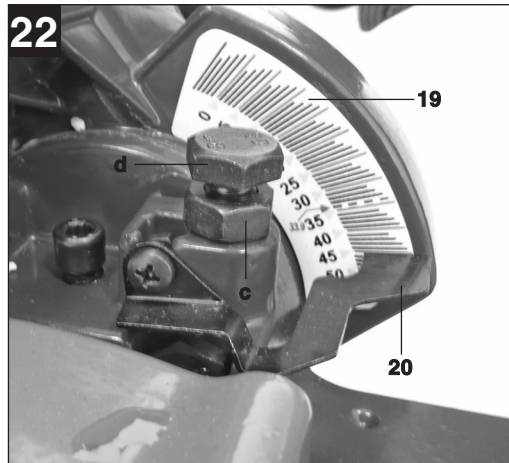
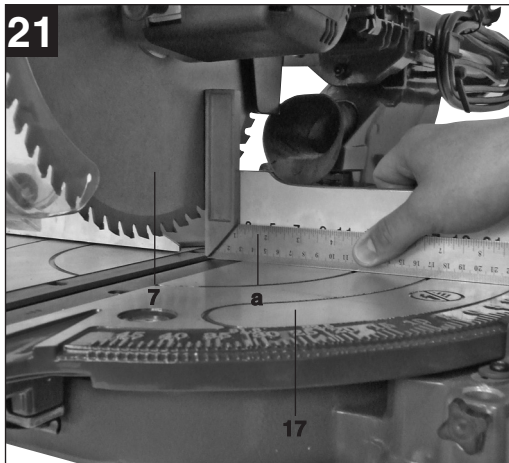
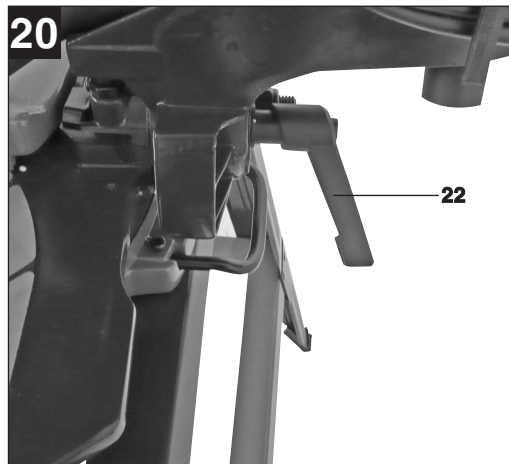
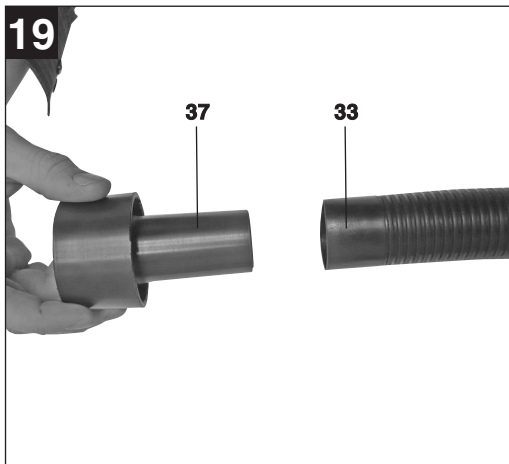
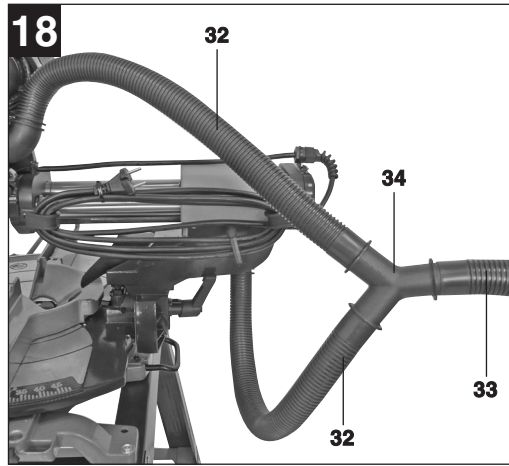
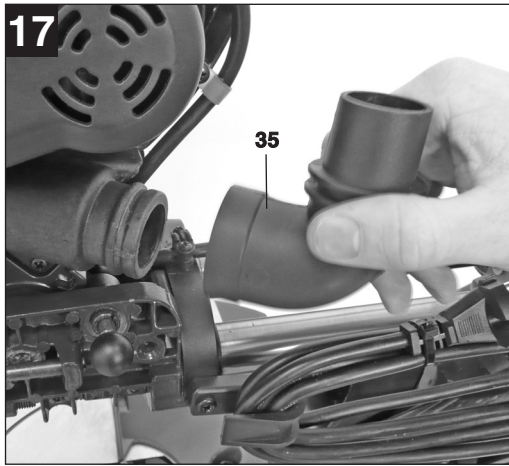

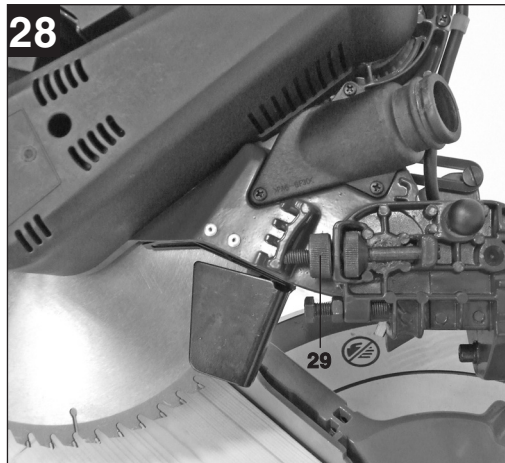
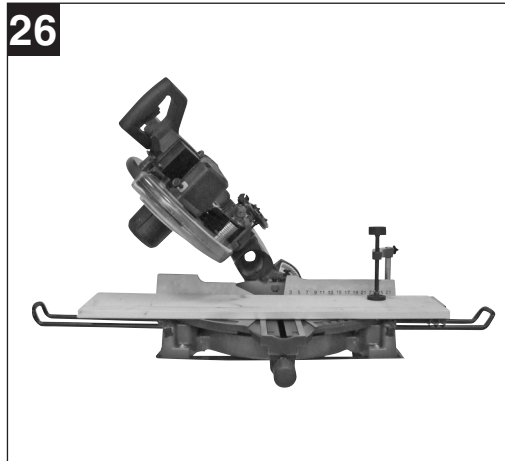
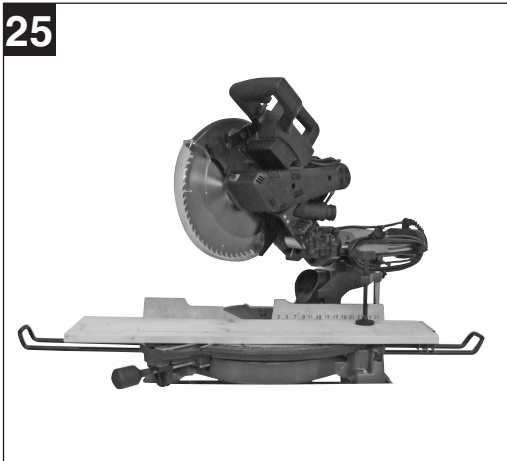
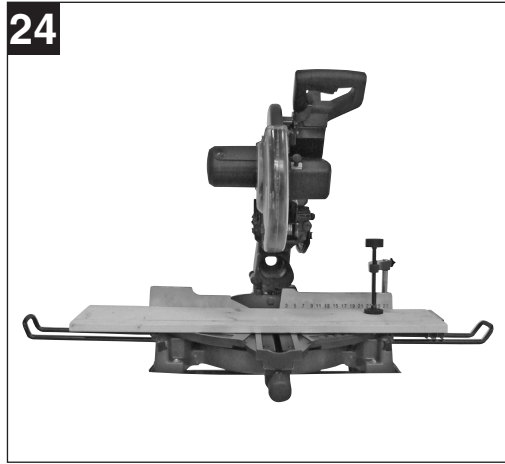
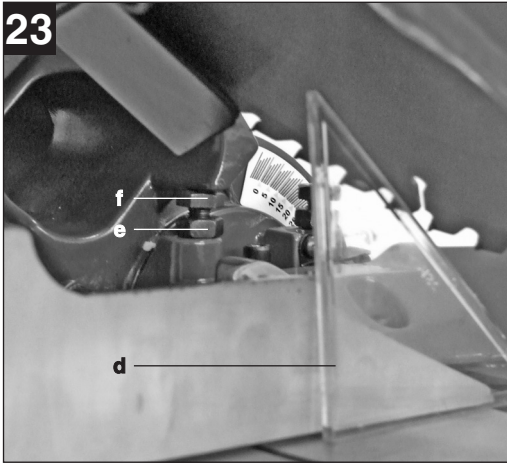

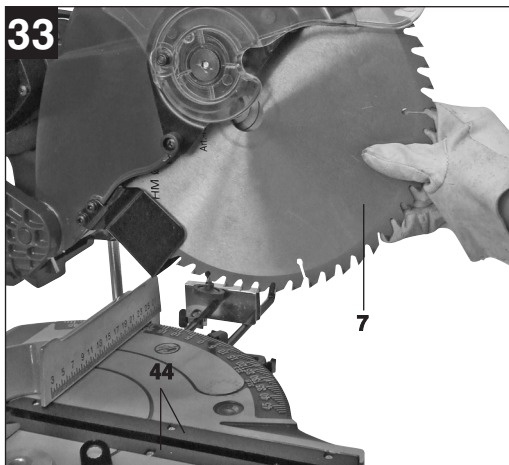
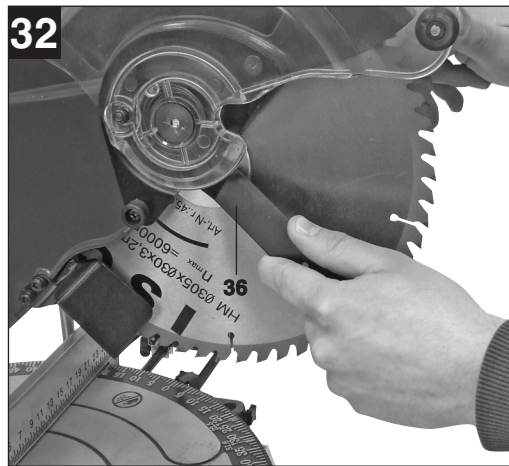
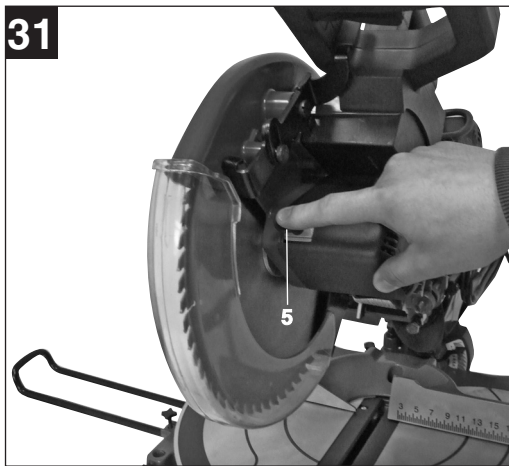
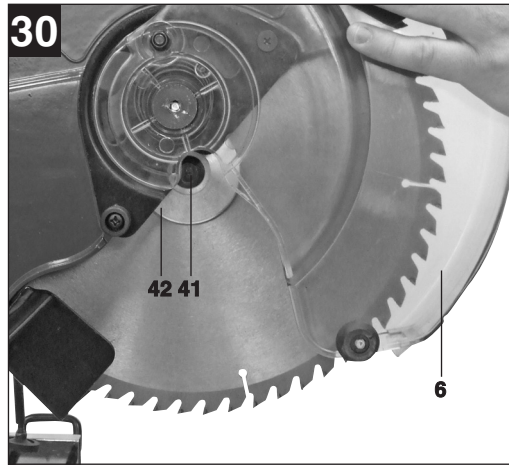
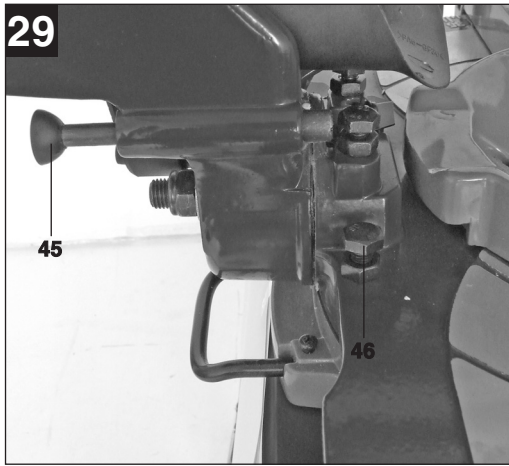

GB

Table of contents:

	Page
1. Safety regulations	11
2. Layout	11
3. Items supplied	11
4. Intended use	11-12
5. Technical data	12
6. Before starting the equipment	12-13
7. Operation	13-14
8. Replacing the power cable	15
9. Cleaning, maintenance and ordering of spare parts	15
10. Disposal and recycling	15

⚠ Important!

When using equipment, a few safety precautions must be observed to avoid injuries and damage. Please read the complete operating manual with due care. Keep this manual in a safe place, so that the information is available at all times. If you give the equipment to any other person, give them these operating instructions as well.

We accept no liability for damage or accidents which arise due to non-observance of these instructions and the safety information.

1. Safety information

Please refer to the booklet included in delivery for the safety instructions.

⚠ CAUTION!**Read all safety regulations and instructions.**

Any errors made in following the safety regulations and instructions may result in an electric shock, fire and/or serious injury.

Keep all safety regulations and instructions in a safe place for future use.

2. Layout**2.1 Drag, crosscut and miter saw (Fig. 1-4)**

1. Handle
2. ON/OFF switch
3. Release lever
4. Machine head
5. Saw shaft lock
6. Movable blade guard
7. Saw blade
8. Clamping device
9. Limit stop
10. Workpiece support
11. Stop rail
12. Scale
13. Fastening holes for table top installation
14. Locking grip
15. Pointer
16. Scale
17. Turntable
18. Fixed saw table
19. Scale
20. Pointer
21. Cable holder
22. Locking screw
23. Dust bag
24. Drag guide
25. Locking screw for drag guide

26. Tipping guard
27. Safety pin
28. Knurled screw for cutting depth limiter
29. Stop for cutting depth limiter
30. Locking screw for workpiece support
31. Extractor adapter
32. Extractor hose, short
33. Extractor hose, long
34. T-piece
35. Angle piece
36. Key for changing the saw blade
37. Reduction
38. Dust extraction nozzle

2.2 Base frame (Fig. 5)

- A Feet
- B Struts (long)
- C Top angle brackets (long)
- D Struts (short)
- E Top angle brackets (short)
- F Screw connector (machine / base frame)
- G Screw connector (base frame)

3. Items supplied (Fig. 1, 5)

- Operating Instructions
- Drag, crosscut and miter Saw
- Base frame

4. Proper use

The drag, circular crosscut and miter saw is designed to crosscut wood and plastic suitable for the machine's size. The saw is not designed for cutting firewood.

The machine is to be used only for its prescribed purpose. Any other use is deemed to be a case of misuse. The user / operator and not the manufacturer will be liable for any damage or injuries of any kind caused as a result of this.

Please note that our equipment has not been designed for use in commercial, trade or industrial applications. Our warranty will be voided if the machine is used in commercial, trade or industrial businesses or for equivalent purposes.

The machine is to be operated only with suitable saw blades. It is prohibited to use any type of cutting-off wheel.

To use the machine properly you must also observe the safety regulations, the assembly instructions and the operating instructions to be found in this manual.

GB

All persons who use and service the machine have to be acquainted with this manual and must be informed about its potential hazards.

It is also imperative to observe the accident prevention regulations in force in your area.

The same applies for the general rules of occupational health and safety.

The manufacturer shall not be liable for any changes made to the machine nor for any damage resulting from such changes.

Even when the machine is used as prescribed it is still impossible to eliminate certain residual risk factors. The following hazards may arise in connection with the machine's construction and design:

- Contact with the saw blade in the uncovered saw zone.
- Reaching into the running saw blade (cut injuries).
- Kick-back of workpieces and parts of workpieces.
- Saw blade fracturing.
- Catapulting of faulty carbide tips from the saw blade.
- Damage to hearing if essential ear-muffs are not worn.
- Harmful emissions of wood dust when the machine is used in closed rooms.

5. Technical data

Asynchronous motor	220 V~ 60 Hz
Output	1600 W
Operating mode	S1
Idle speed n_0	4200 min ⁻¹
Carbide-tipped saw blade	∅ 305 x ∅ 30 x 3,2 mm
Number of teeth	60
Tilting range	-45° / 0° / +45°
Mitre cuts	0° to 45° to the left
Sawing width at 90°	330 x 102 mm
Sawing width at 45°	230 x 102 mm
Sawing width at 2 x 45° (double mitre cuts)	230 x 65 mm
Weight	36,2 kg

Noise emission values

- The saw's noise is measured in accordance with DIN EN ISO 3744; 11/95, E DIN EN 31201; 6/93, ISO 7960 Annex A; 2/95. The machine may exceed 85 dB(A) at the workplace. In this case, noise protection measures need to be introduced for the user (ear-muffs).

12

Idle speed

Sound pressure level L_{pA}	95,9 dB(A)
Sound power level L_{WA}	108,9 dB(A)

„The quoted values are emission values and not necessarily reliable workplace values. Although there is a correlation between emission and immission levels it is impossible to draw any certain conclusions as to the need for additional precautions. Factors with a potential influence on the actual immission level at the workplace include the duration of impact, the type of room, and other sources of noise etc., e.g. the number of machines and other neighbouring operations. Reliable workplace values may also vary from country to country. With this information the user should at least be able to make a better assessment of the dangers and risks involved.“

Total vibration values (vector sum of three directions) determined in accordance with EN 61029.

Vibration emission value $a_{h1} = 2,630 \text{ m/s}^2$

6. Before starting the equipment

6.1 General

- The machine must be firmly mounted in working position, e.g. on a workbench, the base frame supplied with the machine, or similar.
- All the covers and safety devices have to be properly fitted before the machine is switched on.
- It must be possible for the saw blade to run freely.
- When working with wood that has been processed before, watch out for foreign bodies such as nails or screws etc.
- Before you actuate the On/Off switch, make sure that the saw blade is correctly fitted and that the machine's moving parts run smoothly.
- Before you connect the machine to the power supply, make sure the data on the rating plate is the same as that for your mains.

6.2 Assemble the saw (Fig. 1-3; 11; 12)

- To adjust the turntable (17), loosen the locking grip (14) by approx. 2 turns, which frees the turntable (17).
- Turn the turntable (17) and scale pointer (15) to the desired angular setting on the dial (16) and lock into place with the locking grip (14).
- To release the saw from its position at the bottom, pull the retaining pin (27) out of the motor mounting while pressing down lightly on the machine head (4).
- Swing the machine head (4) up until the release

lever (3) latches into place.

- The clamping device (8) can be fitted on the left or right of the fixed saw table (18).
- Undo the locking screws for the workpiece support (30).
- Guide the limit stop (9) over a holding bar (10) and install it on the fixed saw table (18), tightening the appropriate locking screw (30).
- Mount the second holding bar (10) on the opposite side of the saw and secure with the appropriate locking screw (30).
- When the locking screw (22) is loosened, you can tilt the machine head (4) to the left by up to 45°.
- If the machine is used without the base frame the tipping guard (26) must be pulled out. This prevents it tipping over to the rear.

6.3 Assemble the base frame and bolt the saw to the base frame (Fig. 5-10)

- First screw the 2 short upper angle brackets (E) (Please note: The upper angle brackets have oval holes (for fastening the saw), first bolt them loosely from the inside to the top of the feet (A). Then screw the 2 longer upper angle brackets (C) to the feet from the outside so that the oval holes coincide with the mounting holes on the saw.
- Place the base frame on the 4 feet (A) and loosely screw the 2 long (B) and 2 short (D) struts to the 4 feet.
- Align the base frame and tighten all the screws.
- Place the saw on the base frame so that the 4 oval holes on the base frame coincide with the mounting holes on the saw.
- Secure all 4 bolts on the base frame so that they are tight.

6.4 Fitting the dust extraction device (Fig. 13-19)

- Mount the dust extraction nozzle (38) in the outlet opening under the cutting arm.
- Mount the big end of the angle piece (35) on the back of the crosscut and miter saw at the outlet opening. The angle piece has to point to the side or down.
- On the angle piece you can either attach the dust bag (23) or a suction hose for drawing off the saw dust.
- Mount the second angle piece on the upper dust extraction socket (35) and plug on the suction hose (32).
- With the Y-piece (34) you can join together the upper and lower suction hose. Plug the hose with adaptor (37) on the outlet of the Y-piece. You can now connect a suitable dust extractor to the adaptor.

6.5 Final adjustment of the stop for crosscut 90° (Fig. 1-2, 20-22)

- Fasten the turntable (17) in 0° position.
- Undo the securing screw (22) and tilt the machine head (4) as far to the right as possible using the handle (1).
- Place the 90° angular stop (a) between the saw blade (7) and the turntable (17).
- Retighten the counter nut (c) to secure this setting.
- Finally check the position of the pointer (20) on the scale (19). If necessary undo the pointer (20) with a Phillips screwdriver, set it to the 0° position on the scale (19) and tighten the retaining screw again.
- **An angular stop is not supplied.**

6.6 Final adjustment of the stop for meter cut 45° (Fig. 1/2, 23)

- Fasten the turntable (17) in 0° position.
- Undo the securing screw (22) and tilt the machine head (4) to the right to an angle of 45° using the handle (1).
- Place the 45° stop angle (d) between the blade (7) and the turntable (17).
- Undo the counter nut (e) and adjust the adjustment screw (f) until the angle between the saw blade (7) and the turntable (17) is 90°.
- **An angular stop is not supplied.**

7. Operation

7.1 Crosscut 90° and turntable 0° (Fig. 1 – 3, 24)

For cutting widths up to 100 mm it is possible to fix the saw's drag function in its rear position with the fixing screw for drag guide (25). If the cutting width exceeds 100 mm you must ensure that the fixing screw for the drag guide (25) is undone and that the machine head (4) can be moved.

- Move the machine head (4) to its upper position.
- Use the handle (1) to push back the machine head (4) and fix it in this position if required (dependent on the cutting width).
- Place the piece of wood to be cut at the stop rail (11) and on the turntable (17).
- Lock the material with the clamping device (8) on the fixed saw bench (18) to prevent the material from moving during the cutting operation.
- Push down the release lever (3) to release the machine head (4).
- Press the ON/OFF switch (2) to start the motor.
- If the drag guide (24) is fixed: Move the machine head (4) downwards evenly and with gentle pressure using the handle (1) until the saw blade (7) has cut through the workpiece.

GB

- If the drag guide (24) is not fixed:
Pull the machine head (4) as far as possible forwards and then lower it evenly and with gently pressure using the handle (1). Now push the machine head (4) slowly and evenly right to the rear until the saw blade (7) has cut right through the workpiece.
- When the cutting operation is completed, move the machine head (4) back to its upper (home) position and release the ON/OFF button (2).

Important. The integral resetting springs will automatically lift the machine head. Do not simply let go of the handle (1) after cutting, but allow the machine head (4) to rise slowly, applying slight counterpressure as it does so.

7.2 Crosscut 90° and turntable 0° - 45° (Fig. 1 – 3, 25)

The crosscut saw can be used to make angular cuts of 0°- 45° to the left and 0 – 45° to the right relative to the stop rail.

- Release the turntable (17) by slackening the locking grip (14).
- Turn the turntable (17) and scale pointer (15) to the desired angular setting on the dial (16) and lock into place with the locking grip (14).
- Cut as described under section 7.1.

7.3 Miter cut 0°- 45° and turntable 0° (Fig. 1 – 3, 26)

The crosscut saw can be used to make miter cuts of 0° - 45° in relation to the work surface.

- Remove the clamping device (8) if necessary or fit it on the opposite side of the fixed saw bench (18).
- Move the machine head (4) to its upper position.
- Fasten the turntable (17) in 0° position.
- Undo the locking screw (22) and use the handle (1) to tilt the machine head (4) to the left until the pointer (20) points to the required angle on the scale (19).
- Retighten the locking screw (22) and make the cut as described in section 7.1.

7.4 Miter cut 0°- 45° and turntable 0° - 45° (Fig. 1 – 3, 27)

The crosscut saw can be used to make miter cuts of 0°- 45° to the left relative to the work surface and, at the same time, 0° - 45° to the left or 0° - 45° to the right of the stop rail (double miter cut).

- Remove the clamping device (8) if necessary or fit it on the opposite side of the fixed saw bench (18).
- Move the machine head (4) to its upper position.
- Release the turntable (17) by slackening the locking grip (14).

- Use the handle (1) to adjust the turntable (17) to the angle required (in this connection see also section 7.2).
- Retighten the locking grip (14) to secure the turntable in place.
- Undo the locking screw (22) and use the handle (1) to tilt the machine head (4) to the left until it coincides with the required angle value (in this connection see also section 7.3).
- Re-tighten the locking screw (22).
- Cut as described under section 7.1.

7.5 Limiting the cutting depth (Fig. 28)

- The cutting depth can be infinitely adjusted using the screw (29).
- Check the setting by completing a test cut.

7.6 Limiting miter cuts (Fig. 29)

- Slide the bolt (45) forwards
- The screw (46) can be infinitely adjusted and can then be used as a stop for the bolt (45).
- Check the setting by completing a test cut.

7.7 Changing the saw blade (Fig. 1, 30 – 33)

Remove the power plug!

- Swing the machine head (4) upwards and lock it in this position using the locking pin (27).
- Press the release lever (3) and swing up the saw blade guard (6) to the point where the recess in the saw blade guard (6) is above the flange bolt (41).
- Press the saw shaft lock (5) with one hand, while positioning the wrench (36) over the flange bolt (41) with the other.
- Firmly press on the saw shaft lock (5) and slowly rotate the flange bolt (41) in clockwise direction. The saw shaft lock (5) engages after no more than one rotation.
- Now, using a little more force, slacken the flange bolt (41) in the clockwise direction.
- Undo the flange bolt (41) and remove it and them take off the outer flange (42).
- Take the saw blade (7) off the inner flange and pull it out downwards.
- Carefully clean the flange bolt (41), outer flange (42) and inner flange.
- Fit and fasten the new saw blade (7) in reverse order.
- **Important.** The cutting angle of the teeth, in other words the direction of rotation of the saw blade (7) must coincide with the direction of the arrow on the housing.
- Check to make sure that all safety devices are properly mounted and in good working condition before you begin working with the saw again.
- **Important.** Every time that you change the saw

blade, check to see that it spins freely in the table insert (44) in both perpendicular and 45° angle settings.

- Important. The saw blade (7) must be changed and aligned correctly.

7.8 Transport (Fig. 1 – 3)

- Tighten the locking grip (14) to lock the turntable (17).
- Press the release lever (3), push the machine head (4) to the rear and lock it with the locking bolt (27). The saw is now locked in its lower position.
- Secure the drag function of the saw in its rear position using the fixing screw for the drag guide (25).
- Carry the machine using the fixed saw bench (18) or, if the saw is mounted on the base frame, using the appropriate trough handles on the base frame.
- Follow the instructions set out in point 6.2 to erect the machine again.

8. Replacing the power cable

If the power cable for this equipment is damaged, it must be replaced by the manufacturer or its after-sales service or similarly trained personnel to avoid danger.

9. Cleaning, maintenance and ordering of spare parts

Always pull out the mains power plug before starting any cleaning work.

9.1 Cleaning

- Keep all safety devices, air vents and the motor housing free of dirt and dust as far as possible. Wipe the equipment with a clean cloth or blow it with compressed air at low pressure.
- We recommend that you clean the device immediately each time you have finished using it.
- Clean the equipment regularly with a moist cloth and some soft soap. Do not use cleaning agents or solvents; these could attack the plastic parts of the equipment. Ensure that no water can seep into the device.

9.2 Carbon brushes

In case of excessive sparking, have the carbon brushes checked only by a qualified electrician. Important! The carbon brushes should not be replaced by anyone but a qualified electrician.

9.3 Maintenance

There are no parts inside the equipment which require additional maintenance.

9.4 Ordering replacement parts

Please quote the following data when ordering replacement parts:

- Type of machine
 - Article number of the machine
 - Identification number of the machine
 - Replacement part number of the part required
- For our latest prices and information please go to www.isc-gmbh.info

10. Disposal and recycling

The unit is supplied in packaging to prevent its being damaged in transit. This packaging is raw material and can therefore be reused or can be returned to the raw material system.

The unit and its accessories are made of various types of material, such as metal and plastic. Defective components must be disposed of as special waste. Ask your dealer or your local council.

DISTRIBUTOR & A/S CENTER in Korea :

Kubo-Tech, Inc.
D Block Room No. 35-310, Guro Machinery & Tools Shopping Center
604-1, Guro-dong, Guro-gu, Seoul 152-050 Korea
Tel : 02-2675-0942/0943 Fax : 02-2675-0944
e-Mail : smakorea@yahoo.co.kr

©

The reprinting or reproduction by any other means, in whole or in part, of documentation and papers accompanying products is permitted only with the express consent of ISC GmbH.

© Technical changes subject to change



Horizontal lines forming a writing area.

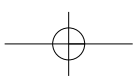

GUARANTEE CERTIFICATE

Dear Customer,

All of our products undergo strict quality checks to ensure that they reach you in perfect condition. In the unlikely event that your device develops a fault, please contact our service department at the address shown on this guarantee card. Of course, if you would prefer to call us then we are also happy to offer our assistance under the service number printed below. Please note the following terms under which guarantee claims can be made:

1. These guarantee terms cover additional guarantee rights and do not affect your statutory warranty rights. We do not charge you for this guarantee.
2. Our guarantee only covers problems caused by material or manufacturing defects, and it is restricted to the rectification of these defects or replacement of the device. Please note that our devices have not been designed for use in commercial, trade or industrial applications. Consequently, the guarantee is invalidated if the equipment is used in commercial, trade or industrial applications or for other equivalent activities. The following are also excluded from our guarantee: compensation for transport damage, damage caused by failure to comply with the installation/assembly instructions or damage caused by unprofessional installation, failure to comply with the operating instructions (e.g. connection to the wrong mains voltage or current type), misuse or inappropriate use (such as overloading of the device or use of non-approved tools or accessories), failure to comply with the maintenance and safety regulations, ingress of foreign bodies into the device (e.g. sand, stones or dust), effects of force or external influences (e.g. damage caused by the device being dropped) and normal wear resulting from proper operation of the device.

The guarantee is rendered null and void if any attempt is made to tamper with the device.

3. The guarantee is valid for a period of 2 years starting from the purchase date of the device. Guarantee claims should be submitted before the end of the guarantee period within two weeks of the defect being noticed. No guarantee claims will be accepted after the end of the guarantee period. The original guarantee period remains applicable to the device even if repairs are carried out or parts are replaced. In such cases, the work performed or parts fitted will not result in an extension of the guarantee period, and no new guarantee will become active for the work performed or parts fitted. This also applies when an on-site service is used.
4. In order to assert your guarantee claim, please send your defective device postage-free to the address shown below. Please enclose either the original or a copy of your sales receipt or another dated proof of purchase. Please keep your sales receipt in a safe place, as it is your proof of purchase. It would help us if you could describe the nature of the problem in as much detail as possible. If the defect is covered by our guarantee then your device will either be repaired immediately and returned to you, or we will send you a new device.

Of course, we are also happy offer a chargeable repair service for any defects which are not covered by the scope of this guarantee or for units which are no longer covered. To take advantage of this service, please send the device to our service address.