

GB

Operating Instructions Jigsaw

Einhell®

1

Art.-Nr.: 43.210.84

I.-Nr.: 11010

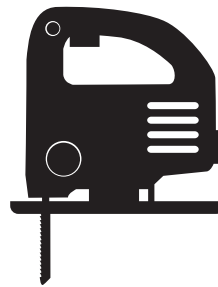

RT-JS **85**



“Caution - Read the operating instructions to reduce the risk of injury”



Wear ear-muffs.

The impact of noise can cause damage to hearing.



Wear a breathing mask.

Dust which is injurious to health can be generated when working on wood and other materials. Never use the device to work on any materials containing asbestos!



Wear safety goggles.

Sparks generated during working or splinters, chips and dust emitted by the device can cause loss of sight.

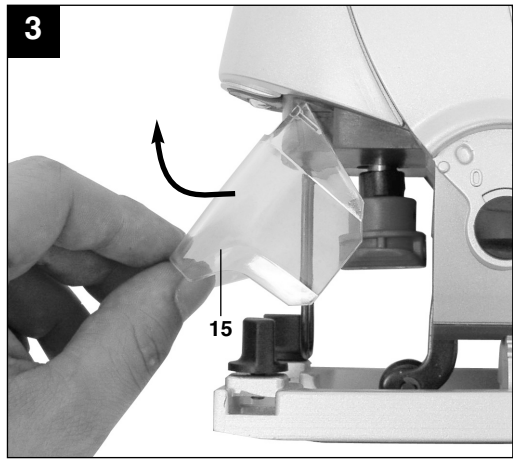
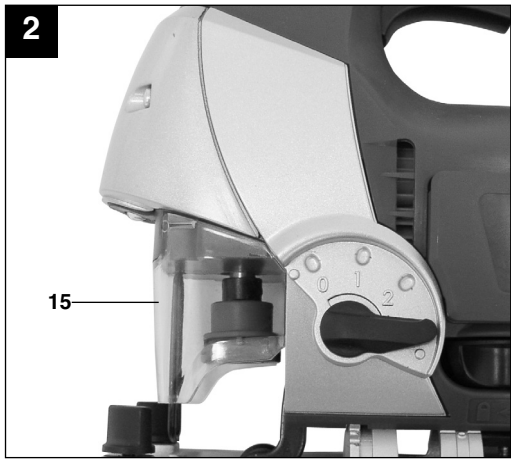
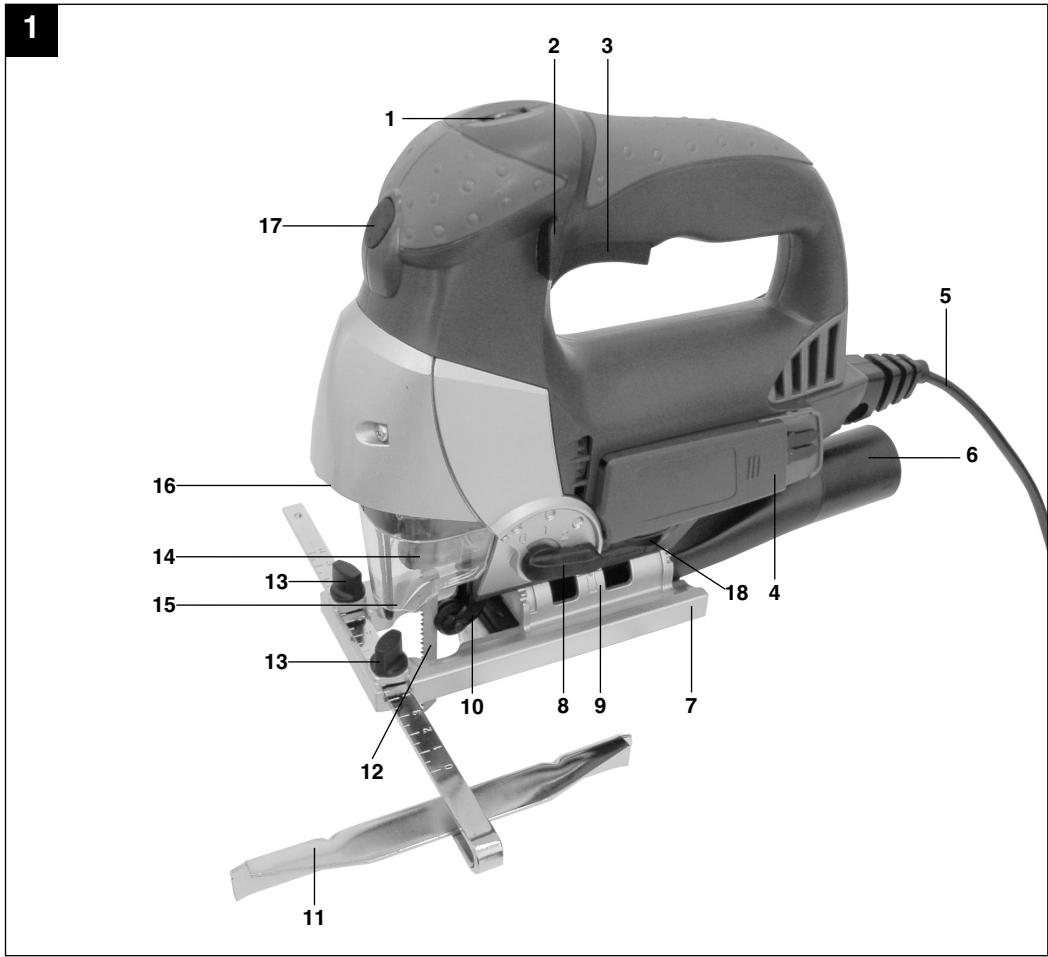

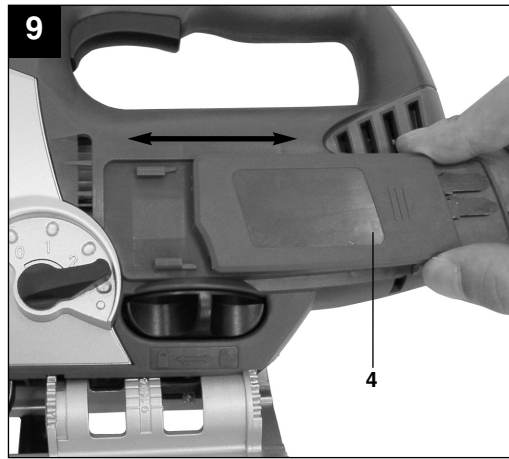
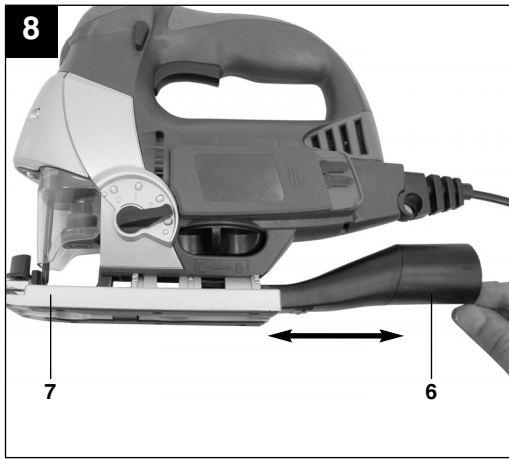
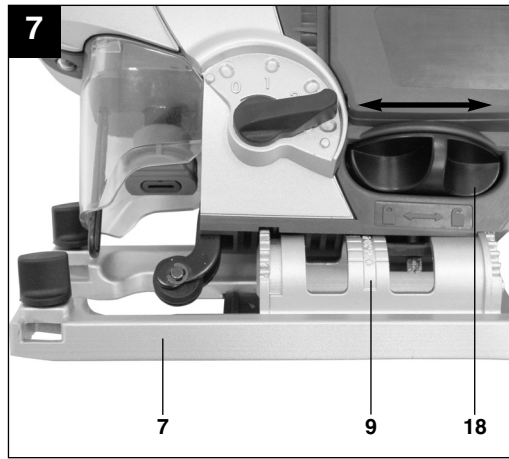
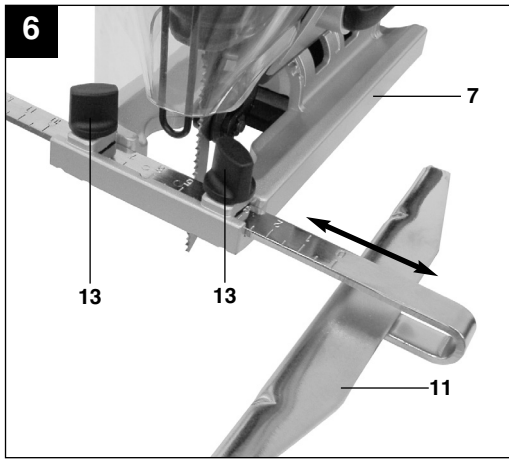
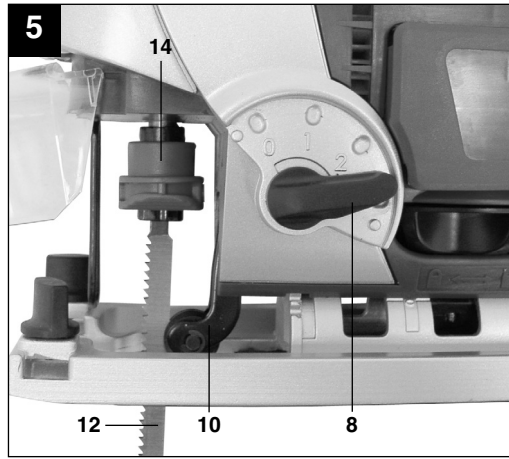
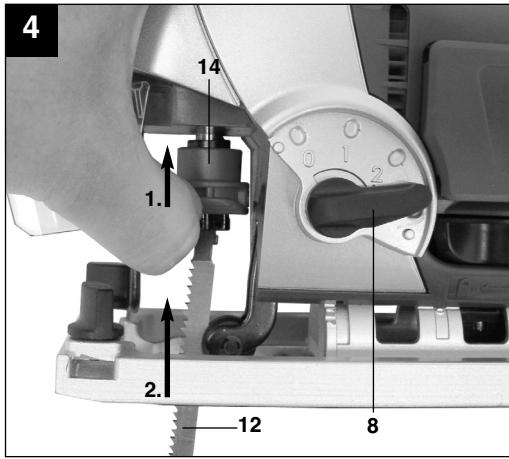

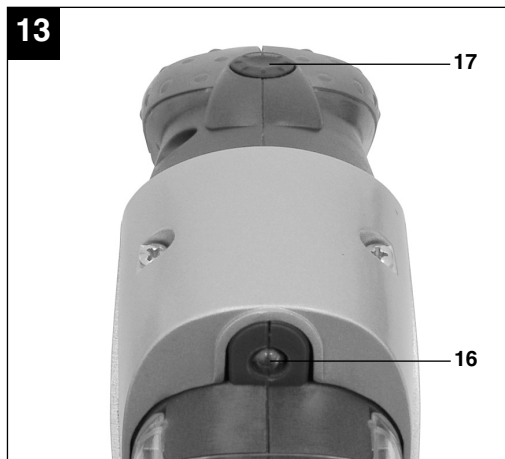
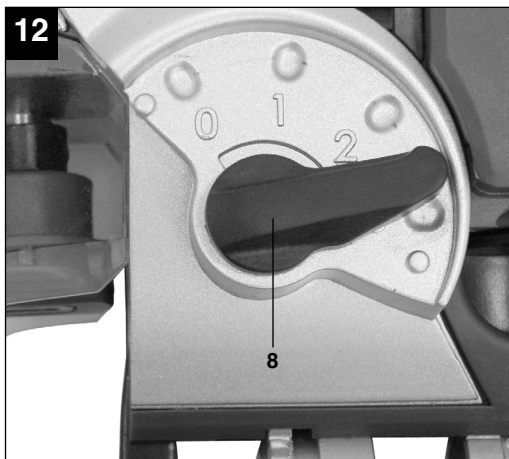
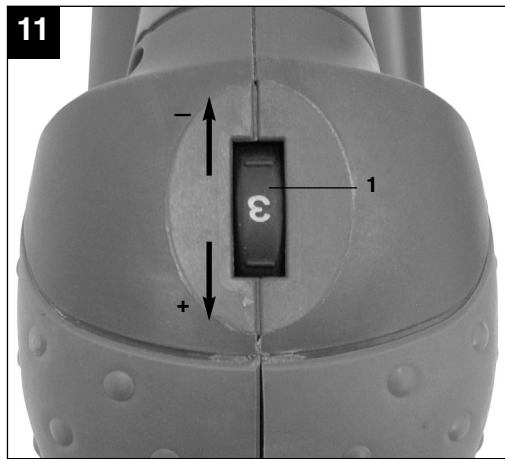
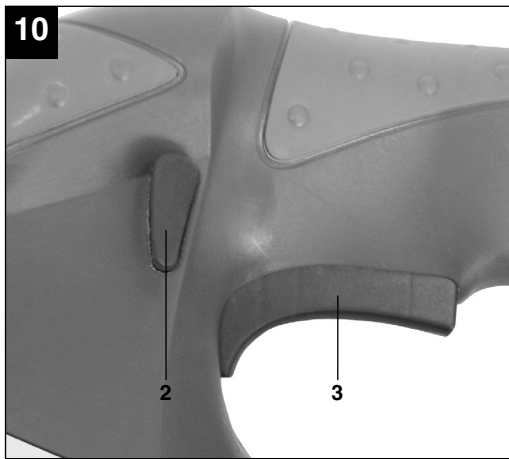

16

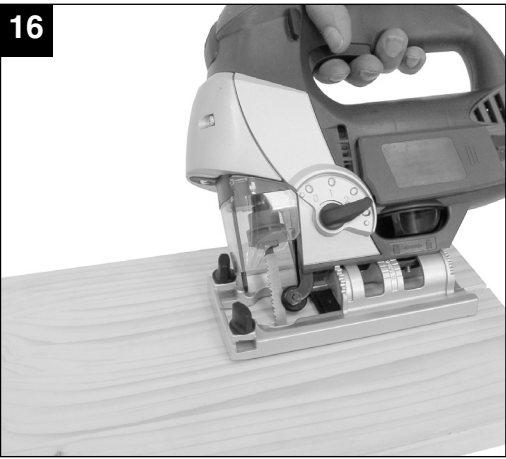

GB**⚠ Important!**

When using the equipment, a few safety precautions must be observed to avoid injuries and damage. Please read the complete operating instructions and safety regulations with due care. Keep this manual in a safe place, so that the information is available at all times. If you give the equipment to any other person, hand over these operating instructions and safety regulations as well. We cannot accept any liability for damage or accidents which arise due to a failure to follow these instructions and the safety instructions.

1. Safety information

Please refer to the booklet included in delivery for the safety instructions.

⚠ CAUTION!**Read all safety regulations and instructions.**

Any errors made in following the safety regulations and instructions may result in an electric shock, fire and/or serious injury.

Keep all safety regulations and instructions in a safe place for future use.

2. Layout (Fig. 1)

1. Knurled screw for speed control
2. Locking button
3. ON/OFF switch
4. Holder for saw blades
5. Power cable
6. Adapter for dust extraction system
7. Adjustable soleplate
8. Selector switch for pendulum action
9. Dial scale for soleplate
10. Guide roller
11. Parallel stop
12. Saw blade
13. Locking screws for parallel stop
14. Blade holder
15. Safety guard
16. LED lamp
17. ON/OFF switch for LED lamp
18. Locking screw for soleplate

3. Proper use

The jigsaw is designed for sawing wood, iron, non-ferrous metals and plastics using the appropriate saw blades.

The machine is to be used only for its prescribed purpose. Any other use is deemed to be a case of misuse. The user / operator and not the manufacturer will be liable for any damage or injuries of any kind caused as a result of this.

Please note that our equipment has not been designed for use in commercial, trade or industrial applications. Our warranty will be voided if the machine is used in commercial, trade or industrial businesses or for equivalent purposes.

4. Technical data

Mains voltage:	230 V~ 50 Hz
Power input:	750 W
Stroke speed:	800 – 3,000 min ⁻¹
Stroke height:	23 mm
Cutting depth, wood:	85 mm
Cutting depth, plastic:	12 mm
Cutting depth, iron:	8 mm
Miter cut:	up to 45° (left and right)
Protection class:	II / 
Weight:	2.5 kg

Sound and vibration

Sound and vibration values were measured in accordance with EN 60745.

L _{pA} sound pressure level	87,3 dB(A)
K _{pA} uncertainty	3 dB
L _{WA} sound power level	98,3 dB(A)
K _{WA} uncertainty	3 dB

Wear ear-muffs.

The impact of noise can cause damage to hearing.

Total vibration values (vector sum of three directions) determined in accordance with EN 60745.

Cutting woodVibration emission value $a_h = 5,573 \text{ m/s}^2$ K uncertainty = $1,5 \text{ m/s}^2$ **Cutting sheet metal**Vibration emission value $a_h = 7,136 \text{ m/s}^2$ K uncertainty = $1,5 \text{ m/s}^2$ **⚠ Important!**

The vibration value changes according to the area of application of the electric tool and may exceed the specified value in exceptional circumstances.

5. Before starting the equipment

Before you connect the equipment to the mains supply make sure that the data on the rating plate are identical to the mains data.

Always pull the power plug before making adjustments to the equipment.

5.1 Safety guard (Fig. 2-3/Item 15)

- The safety guard (15) protects the user from accidentally touching the saw blade (12) and nevertheless enables you a free view of the cutting area.
- The safety guard (15) must always be fitted and in position before starting any sawing work.
- The safety guard (15) can be pulled up as shown in Figure 3.

5.2 Changing the saw blade (Figs. 4-5/Item 12)**⚠ Important!**

- You can fit or replace saw blades without using any other tools.
- Pull the mains plug before you fit or replace a saw blade.
- Set the selector switch for pendulum action (8) to position 3.
- The teeth of the saw blade are very sharp!
- Pull up the safety guard (15) (see point 5.1).
- Press the blade holder (14) and insert the saw blade (12) into the blade holder (14) as far as the stop (Fig. 4). The teeth on the saw blade must be pointing forwards.
- Allow the blade holder (14) to slide back to starting position. The saw blade (12) must sit in the guide roller (10) (Figure 5).
- Check that the saw blade (12) is securely mounted in the blade holder.
- Follow the instructions above in reverse order to remove the saw blade.

5.3 Installing the parallel stop (Figure 6/Item 11)

- The parallel stop (11) enables you to saw parallel cuts.
- Undo the two locking screws (13) on the soleplate (7).
- Now slide the parallel stop (11) into the guides on the soleplate (7). You can fit the parallel stop (11) on either the left or right of the equipment.
- The guide strip must always face downwards. Set the required distance using the measurement scale on the parallel stop (11) and tighten the locking screws (13) again.

5.4 Setting the soleplate for miter cuts (Fig. 7)

- Undo the locking screw (18) on the soleplate.
- Pull the soleplate (7) slightly forward. The soleplate can now be swiveled a maximum 45° to the left and right.
- If the soleplate (7) is pushed back to the rear again it will only function in the locking positions at 0° , 15° , 30° and 45° , which are marked on the graduated scale for the soleplate (9). Move the soleplate into the required position and refasten the locking screw (18).
- However, the soleplate (7) is also easily set to another angle. To do so, slide the soleplate (7) forwards, set the desired angle and refasten the locking screw (18).

5.5 Adapter for dust extraction system (Figure 8/Item 6)

- Connect your jigsaw to a vacuum cleaner using the adaptor for dust extraction (6). This will provide excellent dust extraction on the workpiece. The benefits are that you will protect both the equipment and your own health. Your work area will also be cleaner and safer.
- Dust created when working may be dangerous. Refer to the section entitled "Safety instructions".
- Fit the adapter (6) as shown in Figure 8. The adapter (6) must audibly engage to ensure that it is secure in the soleplate (7). The adapter for chip extraction (6) cannot be used for miter cuts.
- Fit the vacuum tube of the vacuum cleaner onto the adaptor opening (6). Check that the connections are airtight.

5.6 Holder for saw blades (Fig. 9/Item 4)

There is a holder for saw blades on the jigsaw (4). This holder can be taken off the machine. To do this, slide the holder backwards. To secure the holder (4) place it in the appropriate guides and then slide the holder forwards.

GB

6. Operation

6.1 ON/OFF switch (Fig. 10/Item 3)

To switch on:

Press the ON/OFF (3) switch

To switch off:

Release the ON/OFF (3) switch

6.2 Locking button (Fig. 10/Item 2)

You can lock the ON/OFF switch (3) using the locking button (2) when the equipment is in operation. To lock it, press the ON/OFF switch (3) and slide the locking button (2) to the left or right. To switch off the equipment briefly hold down the ON/OFF switch (3).

6.3 Electric speed selector (Fig. 11/Item 1)

You can pre-select the required speed with the speed selector. Turn the speed selector in PLUS direction to increase the speed and turn the speed selector in MINUS direction to reduce the speed. The suitable stroke speed is dependent on the relevant material and working conditions.

General rules for cutting speeds for metal cutting work must be complied with here as well.

You can generally use a higher speed with fine saw blades whilst coarser saw blades require lower speeds.

Position 1-2 = low stroke speed (for steel)

Position 3-4 = medium stroke speed (for steel, soft metal, plastic)

Position 5-6 = high stroke speed (for softwood, hardwood, soft metal, plastic)

6.4 Setting the pendulum action (Fig. 12/Item 8)

- The strength of the pendulum action of the saw blade (12) can be adjusted using the selector switch for pendulum action (8).
- You can adjust the cutting speed, the cutting performance and the finish to the workpiece you wish to saw.

Set the selector switch for pendulum action (8) to one of the following positions:

Position 0: No pendulum action

Material: Rubber, ceramic, aluminium, steel

Please note: For fine and clean cuts, thin materials (e.g. sheet steel) and hard materials.

Position 1: Small pendulum action

Material: Plastic, wood, aluminium

Please note: For hard materials

Position 2: Medium pendulum action

Material: Wood

Position 3: Large pendulum action

Material: Wood

Please note: For soft materials and sawing along the grain

The best combination of speed and pendulum action depends on the material you wish to saw. We recommend you to make a trial cut on a waste piece in order to check the ideal settings.

6.5 LED lamp (Fig. 13/Item 16)

The LED lamp (16) can be used in poor lighting conditions to additionally illuminate the cutting position. Press the switch (17) to switch on. To switch off, press the switch (17) again.

6.6 Making cuts

- Ensure that the ON/OFF switch (3) is not depressed. Only then should you connect the mains plug to a suitable socket.
- Do not switch on the jigsaw until you have fitted a saw blade.
- Use only saw blades that are in perfect condition. Replace blunt, bent or cracked saw blades immediately.
- Place the saw foot flat on the workpiece you wish to saw. Switch on the jigsaw.
- Allow the saw blade to accelerate until it reaches full speed. Then slowly move the saw blade along the cutting line. Only exert gentle pressure on the saw blade as you do so.
- When cutting metal, apply a suitable coolant along the line you wish to cut.

6.7 Sawing out sections (Fig. 14)

Drill a 10 mm hole in the section you wish to saw out. Insert the saw blade into this hole and start to saw out the required section.

6.8 Making parallel cuts

- Mount the parallel stop and adjust as required (see section 5.3).
- Observe the instructions in section 6.6.
- Cut as shown in Figure 15.

6.9 Making miter cuts (Fig. 16)

- Set the angle on the soleplate (see section 5.4).
- Observe the instructions in section 6.6.
- Cut as shown in Figure 16.

7. Replacing the power cable

If the power cable for this equipment is damaged, it must be replaced by the manufacturer or its after-sales service or similarly trained personnel to avoid danger.

types of material, such as metal and plastic. Defective components must be disposed of as special waste. Ask your dealer or your local council.

8. Cleaning, maintenance and ordering of spare parts

Always pull out the mains power plug before starting any cleaning work.

8.1 Cleaning

- Keep all safety devices, air vents and the motor housing free of dirt and dust as far as possible. Wipe the equipment with a clean cloth or blow it with compressed air at low pressure.
- We recommend that you clean the device immediately each time you have finished using it.
- Clean the equipment regularly with a moist cloth and some soft soap. Do not use cleaning agents or solvents; these could attack the plastic parts of the equipment. Ensure that no water can seep into the device.

8.2 Carbon brushes

- In case of excessive sparking, have the carbon brushes checked only by a qualified electrician. Important! The carbon brushes should not be replaced by anyone but a qualified electrician.

8.3 Maintenance

- There are no parts inside the equipment which require additional maintenance.

8.4 Ordering replacement parts:

Please quote the following data when ordering replacement parts:

- Type of machine
- Article number of the machine
- Identification number of the machine
- Replacement part number of the part required

For our latest prices and information please go to www.einhell.com.au

9. Disposal and recycling

The unit is supplied in packaging to prevent its being damaged in transit. This packaging is raw material and can therefore be reused or can be returned to the raw material system.

The unit and its accessories are made of various

The guarantee provided in this Guarantee Certificate is given by Einhell Australia Pty Limited
ACN 134 632 858 of 6/166 Wellington Street, Collingwood, Victoria (Telephone number 1300 922 271)
(Einhell Express Guarantee).

GUARANTEE CERTIFICATE

Dear Customer,

All of our products undergo strict quality checks. In the unlikely event that your device develops a fault, please contact our service department at the address shown on this guarantee certificate. Of course, if you would prefer to call us then we are also happy to offer our assistance under the service number printed below. Please note the following terms under which claims under the Einhell Express Guarantee can be made:

1. The benefits conferred by the Einhell Express Guarantee are in addition to all rights and remedies which you may be entitled to under the Australian Consumer Law, and any other statutory rights you may have under other applicable laws. This Einhell Express Guarantee does not exclude, restrict or modify any such rights or remedies.

We do not charge you for the Einhell Express Guarantee.

2. Our goods come with guarantees that cannot be excluded under the Australian Consumer Law. You are entitled to a replacement or refund for a major failure and for compensation for any other reasonably foreseeable loss or damage. You are also entitled to have the goods repaired or replaced if the goods fail to be of acceptable quality and the failure does not amount to a major failure.
3. The Einhell Express Guarantee only covers problems caused by material or manufacturing defects, and our liability under the Einhell Express Guarantee is limited, at our discretion, to the rectification of these defects or replacement of the product. Please note that the product has not been designed for use in commercial, trade or industrial applications. Consequently, the Einhell Express Guarantee will not apply if the product is used in commercial, trade or industrial applications or for other equivalent activities.
4. The following are also excluded from the Einhell Express Guarantee: compensation for transport damage, damage caused by failure to comply with the installation/assembly instructions or damage caused by unprofessional installation, failure to comply with the operating instructions (e.g. connection to the wrong mains voltage or current type), misuse or inappropriate use (such as overloading of the product or use of non-approved tools or accessories), failure to comply with the maintenance and safety regulations, ingress of foreign bodies into the product (e.g. sand, stones or dust), effects of force or external influences (e.g. damage caused by the product being dropped) and normal wear resulting from proper operation of the product. The Einhell Express Guarantee will also not apply if any attempt is made to tamper with the product.
5. The Einhell Express Guarantee is valid for a period of 2 years starting from the purchase date of the product. Claims made under the Einhell Express Guarantee should be submitted before the end of this guarantee period and within two weeks of the defect being noticed. No claims under the Einhell Express Guarantee will be accepted if submitted after the end of this guarantee period. The original guarantee period remains applicable to the device even if repairs are carried out or parts are replaced. In such cases, the work performed or parts fitted will not result in an extension of the guarantee period for the Einhell Express Guarantee, and the Einhell Express Guarantee will not apply for the work performed or parts fitted. This also applies when an on-site service is used.
6. To make a claim under the Einhell Express Guarantee, please send the relevant product postage-free to the address shown below and enclose either the original or a copy of your sales receipt or another dated proof of purchase. It would help us if you could describe the nature of the problem in as much detail as possible. If the defect is covered by the Einhell Express Guarantee, your product will be repaired immediately and returned to you, or we will send you a new device (at our election).

Any costs incurred by you in making a claim under this Einhell Express Guarantee, unless specified otherwise in this guarantee certificate, must be borne by you.

Of course, we are also happy to offer a chargeable repair service for any defects which are not covered by the scope of the Einhell Express Guarantee or for products which are no longer covered by the Einhell Express Guarantee. To take advantage of this service, please send the product to our service address.

EINHELL AUSTRALIA PTY LTD
6/166 Wellington Street
Collingwood VIC 3066
Australia
Phone: 1300 922 271

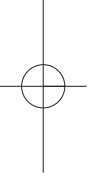
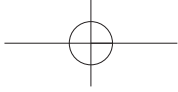

EH 04/2012 (02)

