

QUALCAST

LOVE YOUR
LAWN
THE HEART OF THE GARDEN

163cc Petrol Tiller

Original Operating
Instructions



DEPTH STOP



THROTTLE CONTROL



36CM WORKING WIDTH/
23CM WORKING DEPTH



TILTABLE GUIDANCE
WHEELS



4 TILLER BLADES
*penetrate the soil
automatically and smoothly*



AFTER SALES SUPPORT

UK / IRELAND HELPLINE NO 0151 6491500
REP. IRELAND HELPLINE NO 1890 946244
WEB SUPPORT www.einhell-uk.co.uk

MODEL NUMBER: HQ-MT 3336
HOMEBASE ARTICLE NUMBER: 318775



Contents

- 03. Safety guide
- 05. Assembly and Parts list
- 11. Getting Started
- 13. Operation
- 14. Trouble Shooting
- 16. Declaration of Conformity
- 17. Guarantee Certificate

1. Safety Information

General notes:

- Read the operating instructions carefully. Familiarize yourself with the operator controls and proper operation of the machine.
- Never allow children or other persons who are not familiar with the operating instructions to use the machine.
- Never work in the direct vicinity of persons - especially children or animals.
- Always keep in mind that the machine operator or user is responsible for accidents involving other persons and/or their property.

Preparations:

- Always wear sturdy, non-slip footwear and long trousers when using the machine. Never use the machine barefoot or in sandals.
- Thoroughly check the grounds on which the machine will be used and remove all objects that could be caught up by the machine and violently flung out.
- Warning! Petrol is highly flammable! Therefore:
- Only store petrol in containers designed to hold petroleum-based liquids.
- Only refuel out in the open and do not smoke during the refuelling process.
- Always refuel before starting the engine. Do not open fuel tank cap and do not refuel when the engine is running or when the engine is hot.
- If petrol has overflowed, do not under any circumstances attempt to start the engine. Instead, remove the machine from the affected area. Avoid starting the engine until the petrol fumes have completely evaporated.
- For safety reasons, the petrol tank and other tank closures must be replaced at regular intervals.
- Replace damaged exhaust silencers.
- Before using the machine, always visually examine the tools for excessive wear or damage. To prevent any imbalance, replace worn out or damaged parts and fastening bolts as a set only.

Handling

- Do not let the engine run in enclosed areas, as dangerous carbon monoxide gas can build up.
- Only use the machine in broad daylight or in well-lit conditions.
- Always maintain good footing on inclines.
- Only operate the machine at a walking pace.
- For machines with wheels: Always guide the machine across slopes, i.e. never straight up or straight down.
- Be particularly careful when you change direction on a slope.
- Be particularly careful when you turn the machine around or pull it toward yourself.
- Do not adjust or overclock the engine speed settings.
- Start the engine carefully in accordance with the manufacturer's instructions and ensure that your feet are far enough away from the tool(s).
- Never move your hands or feet toward or under any rotating parts.
- Never lift or carry a machine with the engine running.
- Always stop the engine.
 - Whenever you leave the machine;
 - Before refuelling;
 - Close the engine's throttle valve when the engine runs down.
- When you have finished working with the machine, close the petrol stopcock if it has one.
- For safety reasons the engine speed is not permitted to exceed the speed shown on the motor rating plate.
- Start the engine carefully in accordance with the operating instructions. Never attempt to touch any moving parts while the engine is running.

Maintenance and storage:

- Make sure that all nuts, bolts and screws are tightened securely at all times to ensure that the machine is in a safe working condition.
- Never store the machine (with petrol in the tank) inside a building in which petrol fumes could come into contact with open flames or sparks.
- Allow the engine to cool before you put the machine in an enclosed area.
- In order to avoid fire hazards, keep the engine and exhaust free from all vegetation matter and leaking grease (oil).
- For your own safety, replace worn or damaged parts without delay;
- If the tank needs to be emptied, ensure that it is done out in the open.

Screw fitting sizes

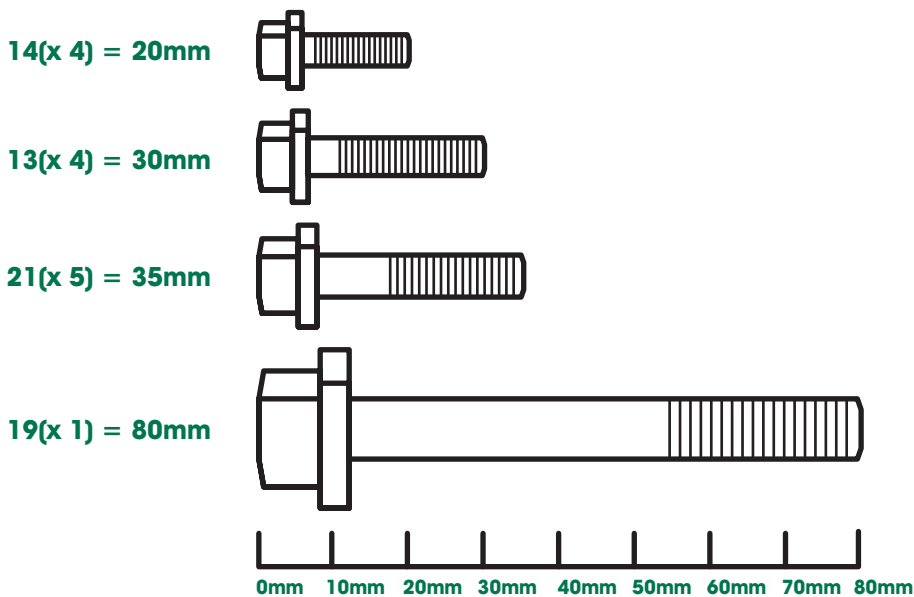

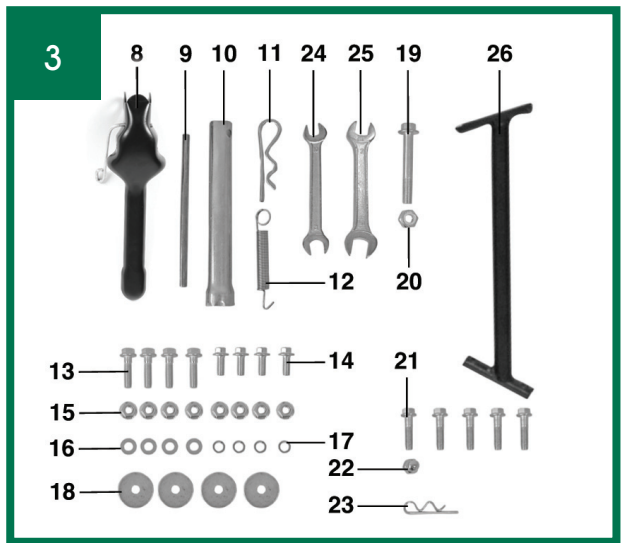
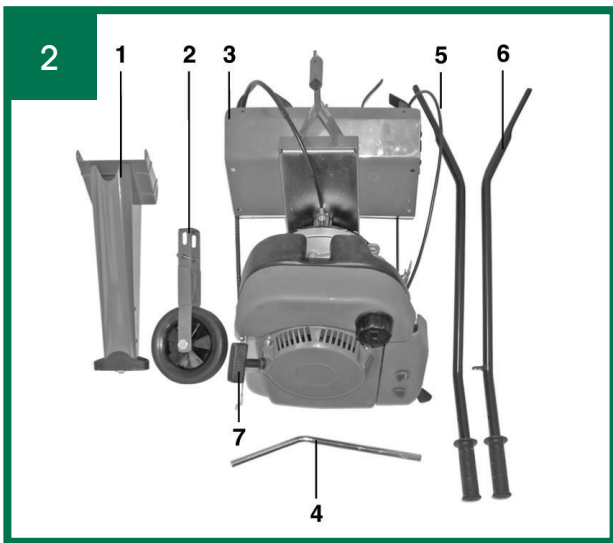
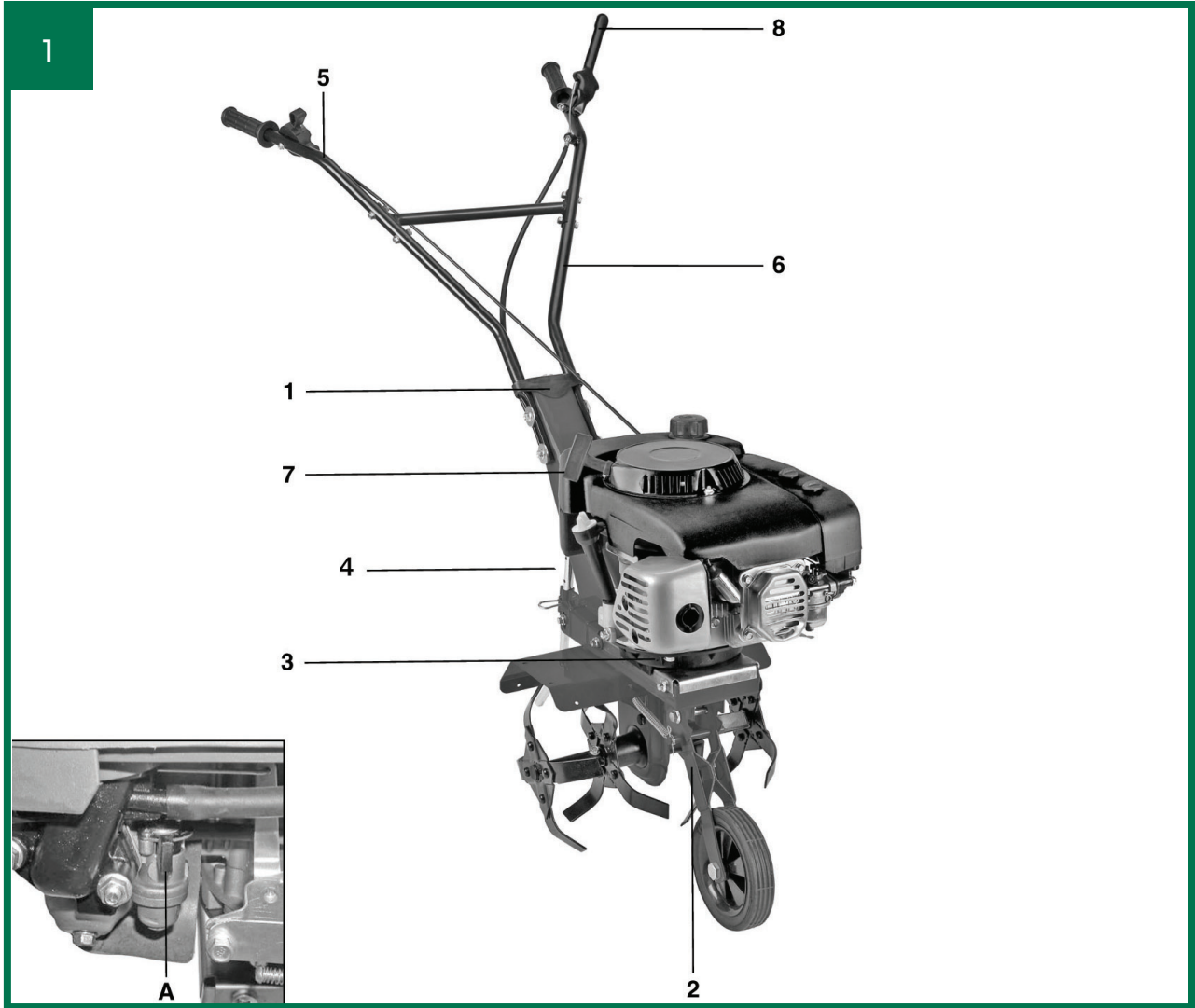

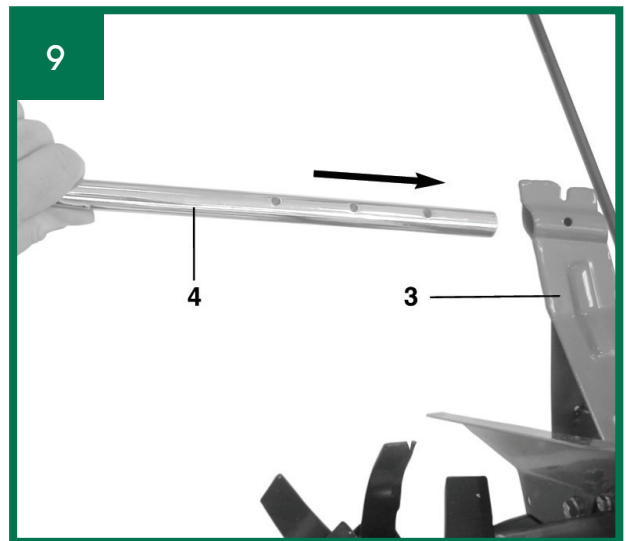
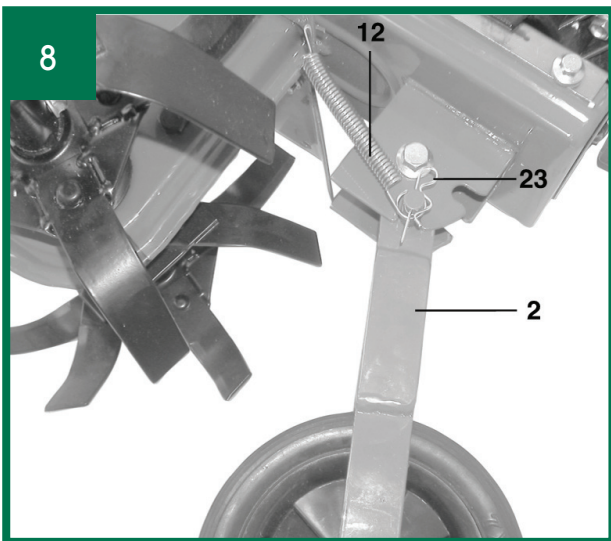
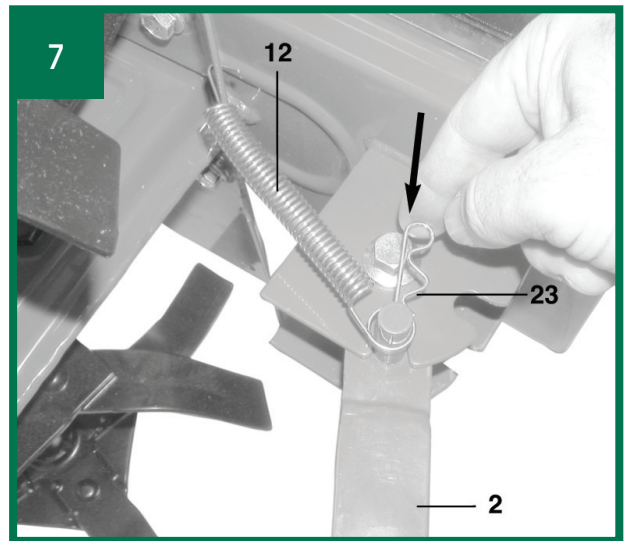
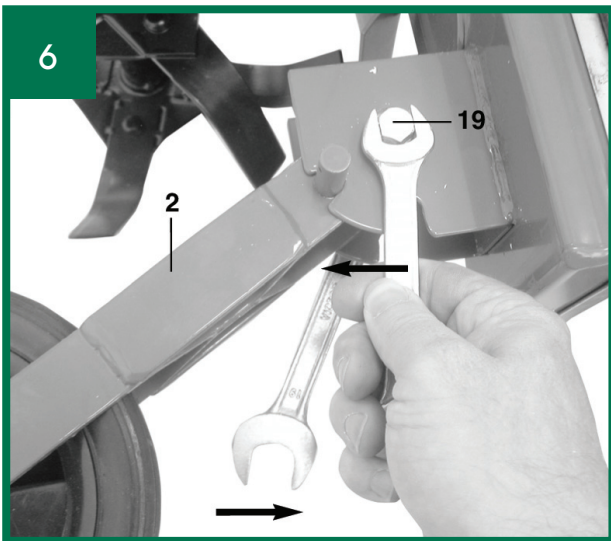
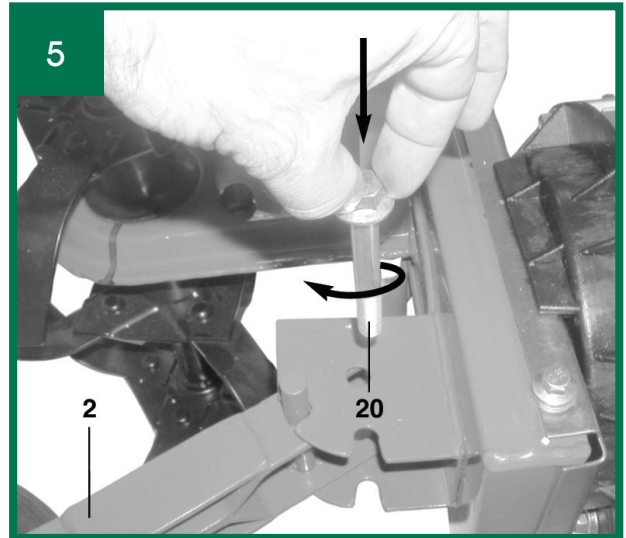
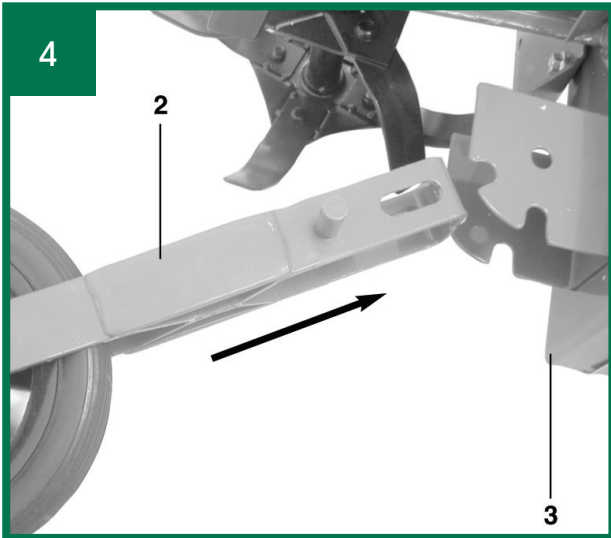

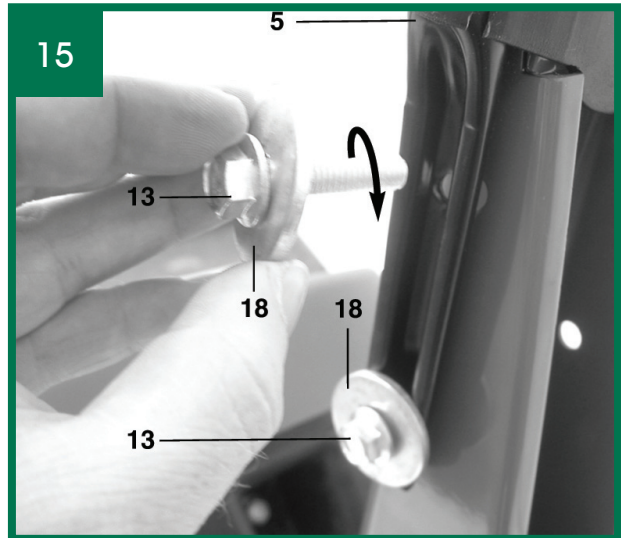
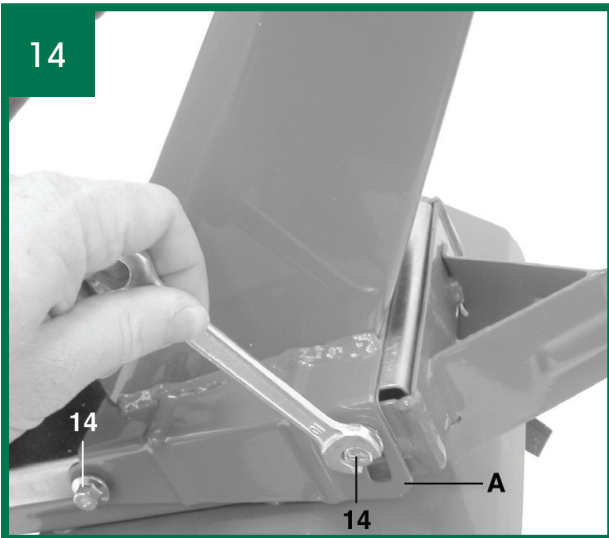
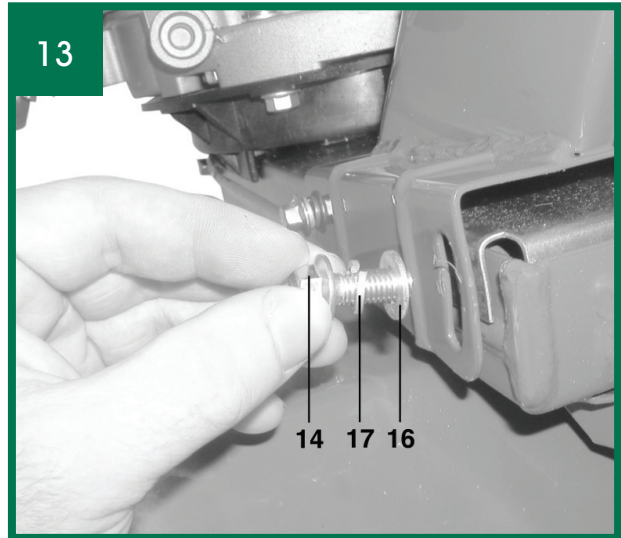
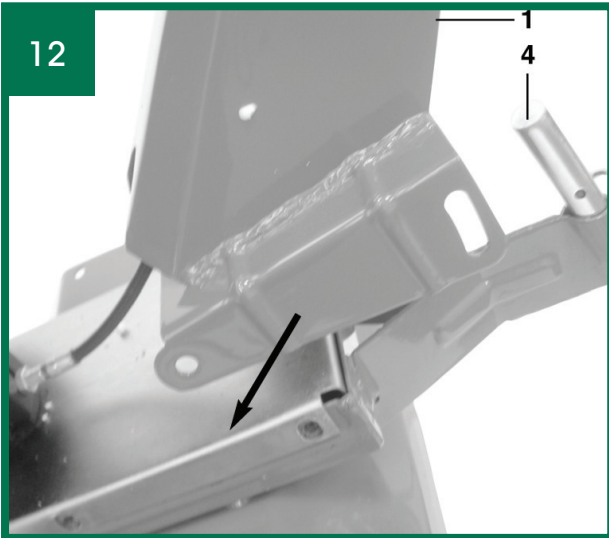
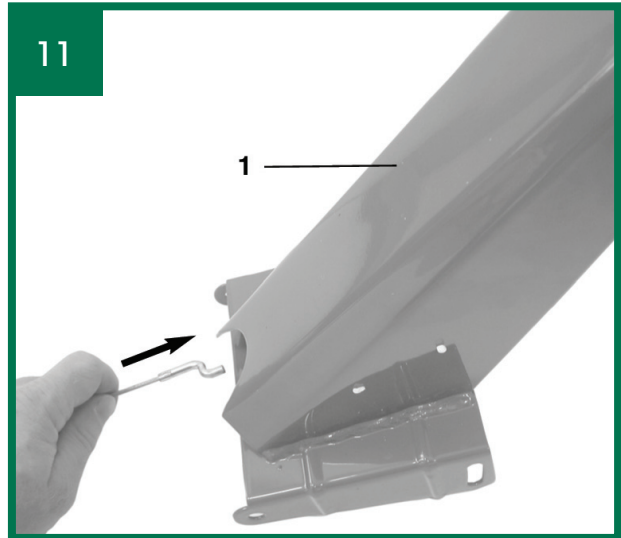
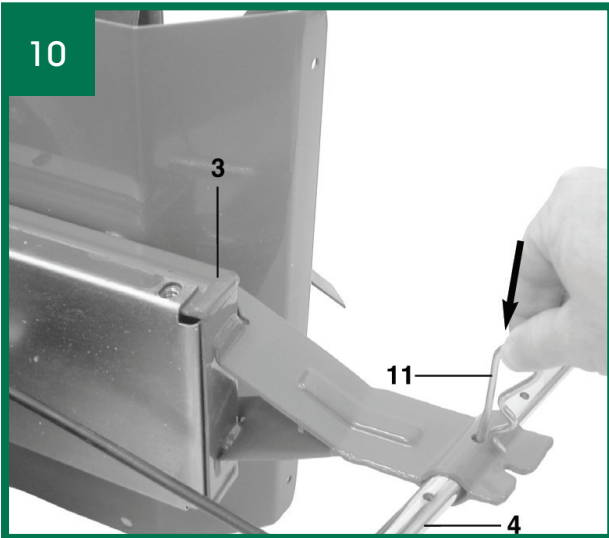

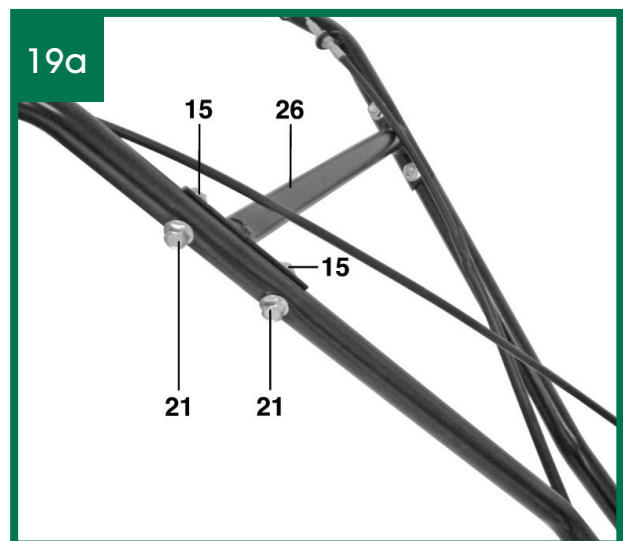
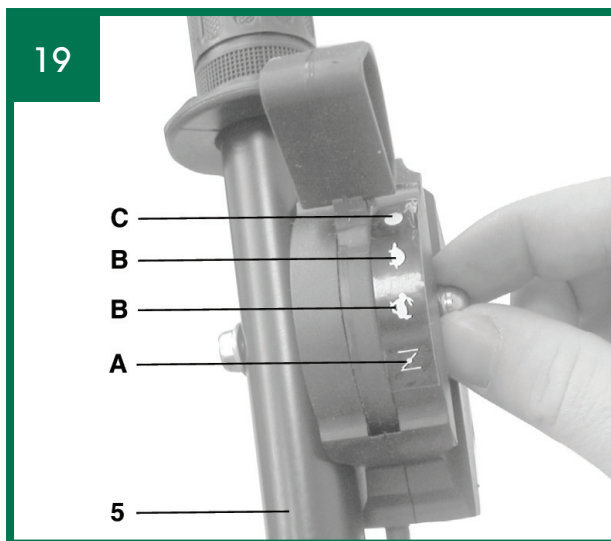
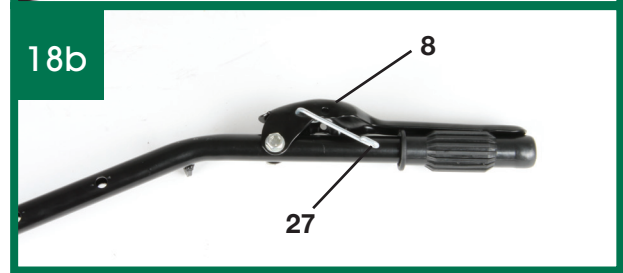
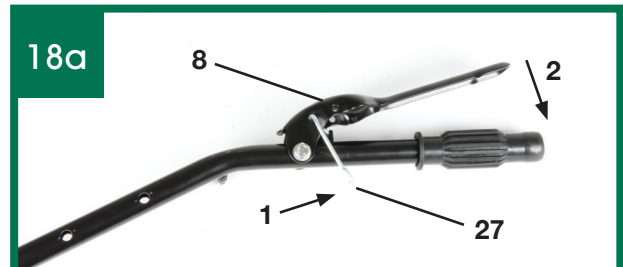
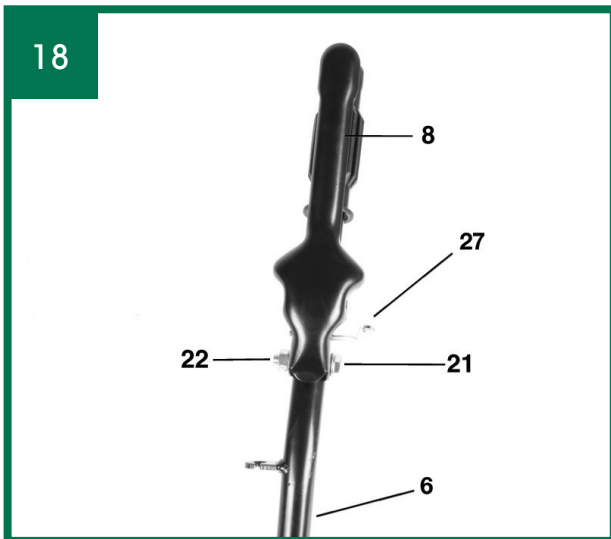
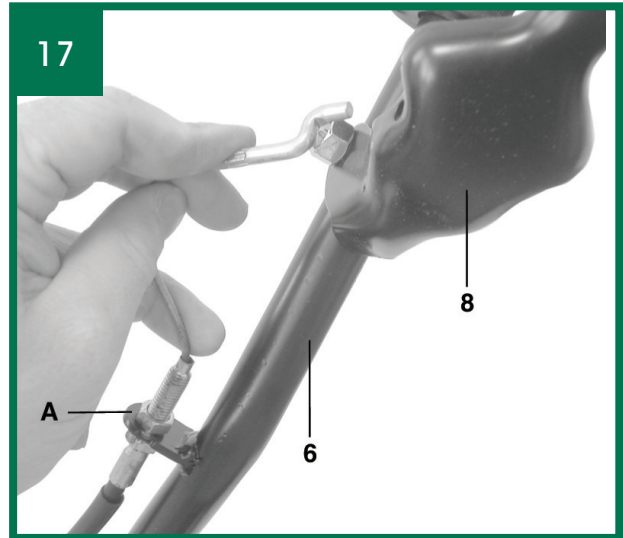
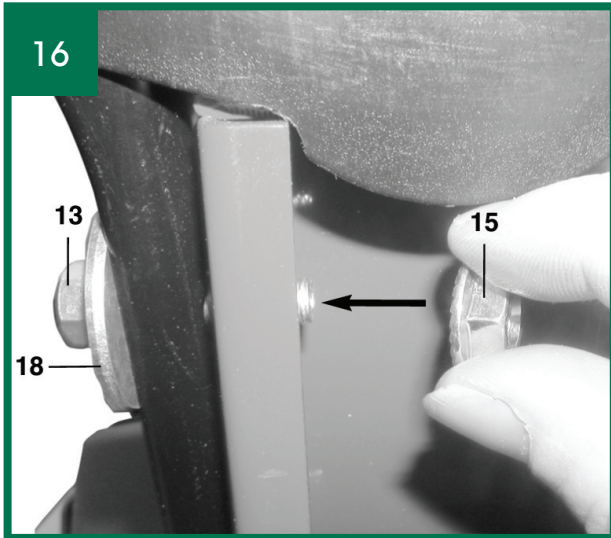

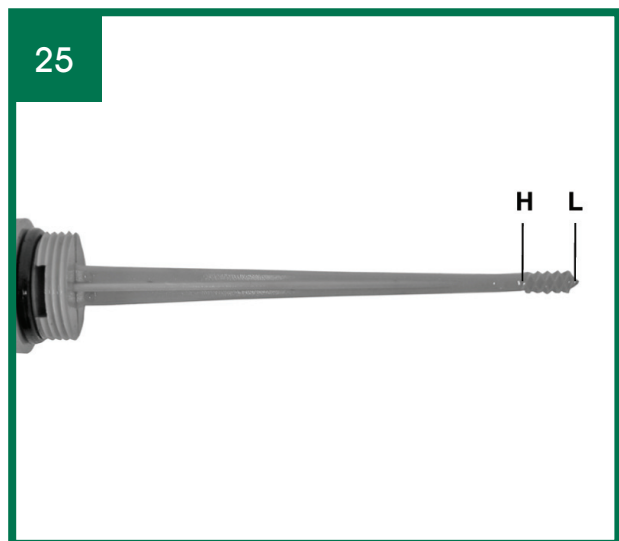
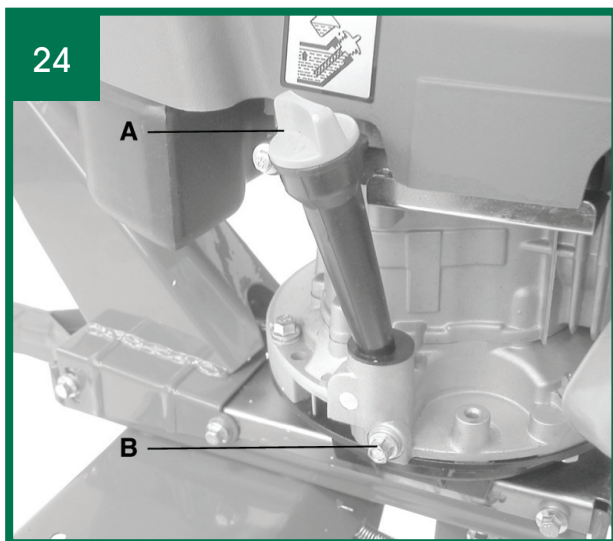
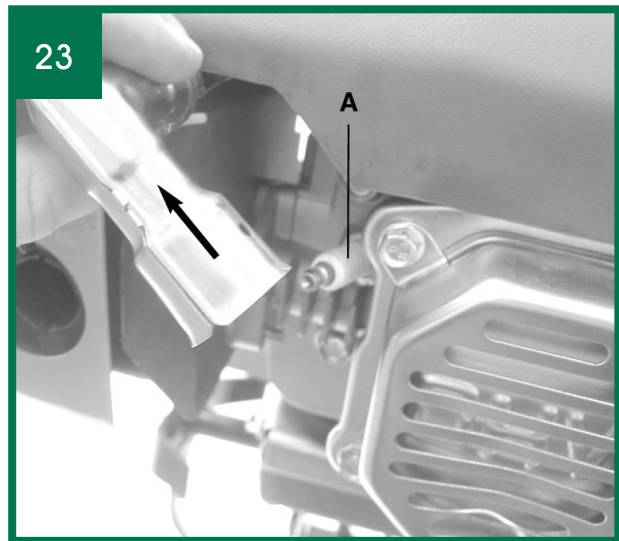
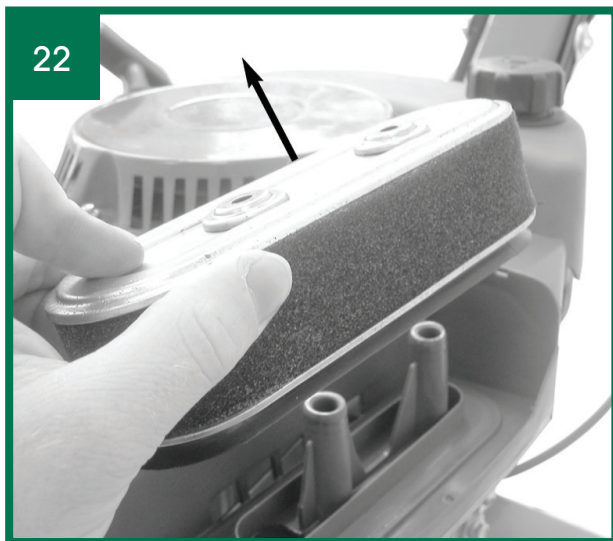
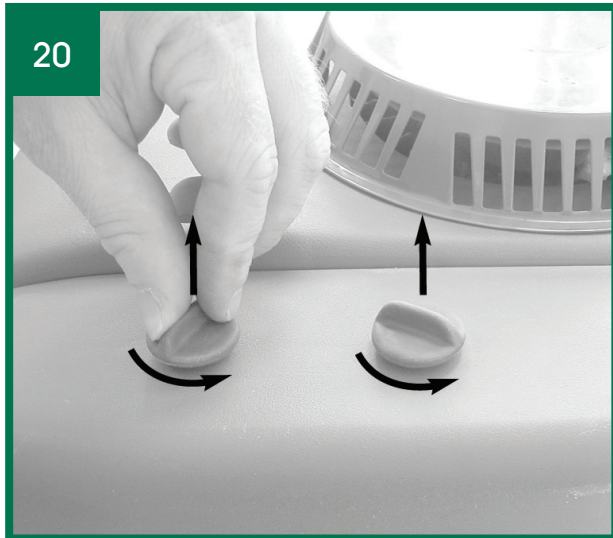

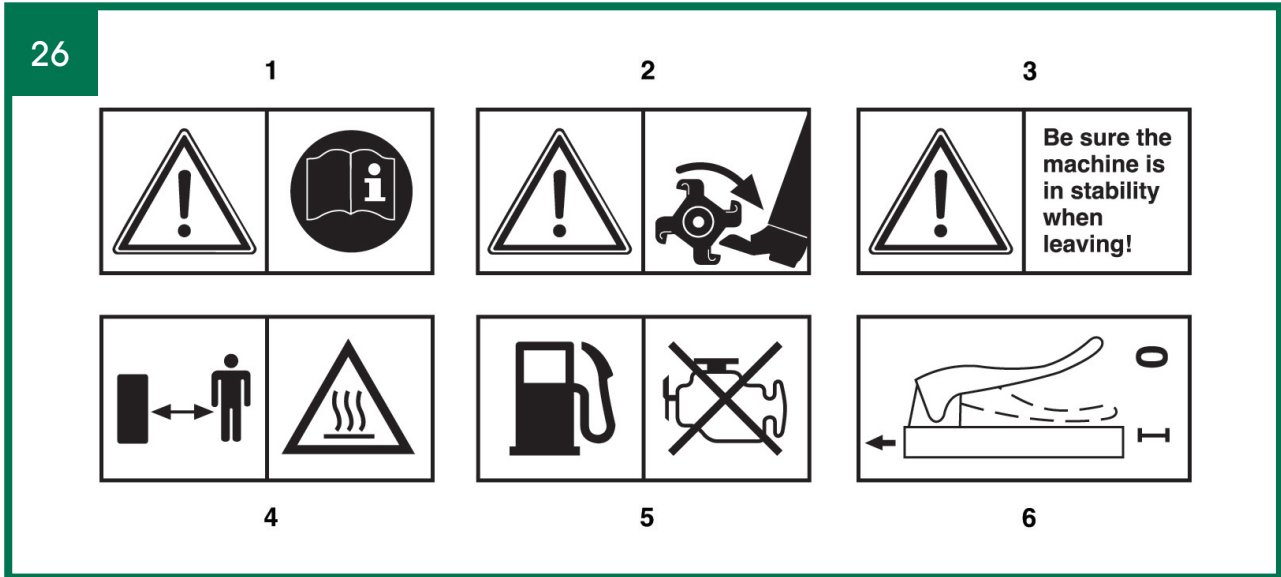

Important!

When using the equipment, a few safety precautions must be observed to avoid injuries and damage. Please read the complete operating manual with due care. Keep this manual in a safe place, so that the information is available at all times. If you give the equipment to any other person, give them these operating instructions as well.

We accept no liability for damage or accidents which arise due to non-observance of these instructions and the safety information.

1. Safety information

CAUTION!

Read all safety regulations and instructions.

Any errors made in following the safety regulations and instructions may result in an electric shock, fire and/or serious injury.

Keep all safety regulations and instructions in a safe place for future use.

Explanation of the symbols on the machine (Fig. 26):

- 1 Important! Read the operating instructions. Follow the warnings and safety instructions.
- 2 Important! Risk of injury from rotating parts. Keep your hands, feet and clothing away from these parts.
- 3 Always make sure that the machine is standing solidly whenever you leave it.
- 4 Important! Hot machine parts. Keep your distance.
- 5 Important! Switch off the engine before refueling.
- 6 Description of the clutch lever: 0 = tiller blade "Stop"; 1 = tiller blade "On/Run"

2. Layout (Fig. 1-3)

- 1 Holder for steering handle
- 2 Transport wheel with holder
- 3 Engine / gear unit
- 4 Depth stop
- 5 Steering handle – throttle lever
- 6 Steering handle – clutch handle
- 7 Hand pull starter
- 8 Clutch handle
- 9 Bar for spark plug wrench
- 10 Spark plug wrench
- 11 Safety split pin for depth stop
- 12 Resetting spring for transport wheel
- 13 Four screws size M6 x 30mm for fastening the steering handle
- 14 Four screws size M6 x 20mm for the steering handle holder
- 15 8 x nuts size M6
- 16 Four M6 washers
- 17 Four M6 spring washers
- 18 Four large M6 washers
- 19 Screw size M8 x 80mm
- 20 Nut size M8
- 21 5 x Screw size M6 x 35mm
- 22 Domed nut size M6
- 23 Safety split pin for resetting spring
- 24 Open-ended spanner size 10/12
- 25 Open-ended spanner size 13/15
- 26 Cross strut
- 27 Clutch Handle Lock

3. Proper use

The machine is designed for digging over beds and fields. Be sure to observe the restrictions in the safety instructions (Section.1 . Page 3).

The machine is to be used only for its prescribed purpose. Any other use is deemed to be a case of misuse. The user / operator and not the manufacturer will be liable for any damage or injuries of any kind caused as a result of this.

Please note that our equipment has not been designed for use in commercial, trade or industrial applications. Our warranty will be voided if the machine is used in commercial, trade or industrial businesses or for equivalent purposes.

4. Technical data

Engine:	4-stroke engine, 163 ccm
Engine rating:	3.3 kW / 4.5 hp
Engine working speed:	3600 rpm
Working width:	36 cm
Tiller blade diameter:	26 cm
Forward gear:	1
Starting system:	Hand pull starter
Fuel:	Regular unleaded petrol
Engine oil:	approx. 0.6 l (10W30)
Tank capacity:	approx. 2.2 l
Vibration ahv:	6.1 m/s ²
Weight:	34 kg
Spark plug:	F7 TC



5. Before starting the equipment

1. Place the engine/gear unit (3) on its left side (air filter / carburettor) and then assemble the petrol tiller as follows. (Use the spanners 24 & 25 to tighten / loosen the screws and nuts).
2. Insert the transport wheel holder in the mount on the drive unit (see Fig. 4).
3. Fasten the transport wheel holder with the help of the screw (19) and the nut (20) (see Fig. 5 and 6).
4. Tension the resetting spring between the engine unit and the transport wheel holder (2). To do so, first hang the hook of the spring (12) in the hole on the inside of the gear (3) unit in the hole provided. Then fit the eyelet on the spring onto the bolt notches on the transport wheel (2). Now insert the safety split pin (23) in the bolt hole provided on the transport wheel to secure the spring and ensure that it cannot slip off (Fig. 7-8).
5. Insert the depth stop (4) in the opening at the back of the gear unit (3) and fasten it with the safety split pin (11) at the working height you require (3 positions are available; when using for the first time we would recommend the middle position) (Fig. 9-10).
6. Stand the petrol tiller upright and feed the Bowden wire for the clutch through the lower opening in the holder for the steering handles (Fig. 11).
7. Fit the holder for the steering handles (1) to the engine unit (3) and fasten with the screws (14), the spring washer (17) and the washers (16) as shown in Fig. 12-14.
8. Then fit the steering handles through the openings on the holder for the steering handles (6) on the left hand side and (5) on the right hand side and fasten with the screws (13), large M6 washers (18) and nuts (15) as shown in Fig. 15-16.
9. Feed the clutch cable through the holder for the steering handles and fasten the Bowden wire adjuster to the eyelet provided on the steering handle by unscrewing the upper lock nut and inserting the thread on the adjuster through the eyelet. Then attach the Bowden wire to the clutch lever (see fig.17).
10. Fit the clutch lever to the left-hand steering handle and fasten the clutch lever to the steering handle with the screw (21) and the domed nut (22) (see Fig.18 / Fig.18b).
11. Adjust the cable to the right length with the help of the adjuster (see Fig. 17/A) as follows: When the clutch lever is pressed there must be sufficient tension in the V-belt for the star-type tiller blades to turn, whereas when the clutch lever is released the star-type tiller blades must not move. Then tighten the two nuts against each other. Ensure that the Clutch Handle Lock functions correctly, before starting the engine. You should not be able to operate the clutch Handle, until the Clutch Handle Lock is in the correct position. (Fig 18a = stopped. Fig. 18b = Blades will rotate).
12. To fit the throttle lever, first unscrew the screws on the throttle lever. Then attach the throttle lever to the right-hand steering handle (5) (Fig.19).
13. Fit the cross strut (26) using the screws (21) and nuts (15) as shown in Figure 19a.

Important! You must fill up with engine oil and fuel before you can start the engine.

- Check the fuel and engine oil levels and refill or top up if required.
- Make sure that the ignition cable is secured to the spark plug.
- Check the area immediately around the petrol tiller.

6. Operation

- Set the depth stop (4) to the desired depth and secure with the split pin.
- Swing the transport wheel up and make sure that the bolt is engaged in the notch in the mount at the front.
- Push the petrol fuel tap (Fig. 1/Item A) to the "ON" position. (Push the lever towards the engine).
- Push the starter lever down to the "Choke" position (Fig. 19/Item A). 
- Pull the start cable (7) gently until you feel resistance, then pull vigorously. If the engine does not start up immediately, repeat the above steps.
- Move the starter lever to the position in the middle (Fig. 19/Item B) = working position (Engine speed: fast()/slow()).
- Starter lever position (Fig. 19/Item C) = stop engine ('0').
- Depending on how tall you are you can adjust the complete holder for the steering handles to the top position. To do so, loosen the screws (Fig. 14/Item A), adjust the bracket and retighten the screws.
- To start the star-type tiller blades, rotate the clutch handle lock (27) counterclockwise and press the clutch handle (8) down and hold in this position (See Fig. 18 / Fig. 18b). Releasing the clutch handle brings the star type tiller blades to a stop (if they do not stop, readjust the clutch cable).
- If the engine is to be stopped for some time, then pull the fuel tap lever to the 'OFF' position (Lever pointing away from the engine). (Fig. 1/Item A).

7. Cleaning, maintenance, storage and ordering of spare parts

Pull off the spark plug boot (fig.23) before doing

any cleaning and maintenance work. Also pull the fuel tap lever to the 'OFF' position (Lever pointing away from the engine). (Fig.1/Item A).

7.1 Cleaning

- Keep all safety devices, air vents and the motor housing free of dirt and dust as much as possible. Wipe the equipment with a clean cloth or blow it with compressed air at low pressure..
- We recommend that you clean the device immediately each time you have finished using it.
- Clean the equipment regularly with a moist cloth and some soft soap. Do not use cleaning agents or solvents; these could attack the plastic parts of the equipment. Ensure that no water can seep into the device.

7.2 Maintenance

Please note: Switch off the unit immediately and contact the UK helpline 0151 649 1500

- In the event of unusual vibrations or noise.
- If the engine appears to be overloaded or misfires.

7.2.1 Air filter maintenance

- Check and clean the air filter before every use, and replace it if necessary.
- Undo the screw on the air filter cover (Fig. 20) and remove the cover (Fig. 21).
- Remove the filter element (Fig. 22).
- Do not use abrasive cleaning agents or petrol to clean the element.
- Clean the element by tapping it on a flat surface.
- Assemble in reverse order.

7.2.2 Spark plug maintenance

Check the spark plug for dirt and grime after 10 hours of operation and if necessary clean it with a copper wire brush. Thereafter service the spark plug after every 50 hours of operation.

- Pull off the spark plug boot (Fig. 23) with a twist.
- Remove the spark plug (Fig. 23/Item A with the supplied spark plug wrench and bar.
- Assemble in reverse order.

7.2.3 Changing the oil and checking the oil level (before using the machine)

The motor oil is best changed when the motor is at working temperature and the tiller is on a flat surface with the motor level.

- Use only engine oil (10W30).
- Take out the dip stick (Fig. 24 / Item A).
- Open the drain screw (Fig. 24 / Item B) and allow the warm oil to drain into a drip tray.
- Close the drain screw again when all the waste oil has been drained.
- Fill up with engine oil as far as the top mark on the dip stick (Fig. 25/H).
- Important: Do not screw the dip stick when you check the oil level, simply insert it as far as the thread (H = Max. / L = Min.).
- Dispose of the waste oil properly.

7.2.4 Adjusting the Bowden wires

In the working setting it should be possible to push the clutch lever up to the push bar without this requiring much effort. If the Bowden wire is too taut for this, it must be extended. To do this, undo the lock nut opposite the main cable, extend the screw connector and then tighten the lock nut again (see Fig. 17/A). If the star-type tiller blades no longer rotate then the screw connector will have to be shortened again (as described above).

7.2.5 Power cultivator gearing

The gear unit is driven by a V-belt. The gear unit can be repaired if this should become necessary. If repairs are necessary, please contact our UK customer service centre - 0151 649 1500.

7.3 Storage

Pull the fuel tap lever to the 'OFF' position (Lever pointing away from the engine). (Fig. 1/Item A) and empty the fuel tank before you decommission the unit for a lengthy period of time. Clean the unit.

7.4 Ordering spare parts

Please provide the following information on all orders for spare parts:

- Model/type of machine (HQ-MT 3336)
- Article number of the machine (34.302.79)
- ID number of the machine (11020)
- Number of the required spare part

For our latest spare part prices and availability please call 0151 649 1500 or visit www.einhell-uk.co.uk.

8. Disposal and recycling

The unit is supplied in packaging to prevent its being damaged in transit. This packaging is raw material and can therefore be reused or can be returned to the raw material system.

The unit and its accessories are made of various types of material, such as metal and plastic. Defective components must be disposed of as special waste. Ask your dealer or your local council.

9. Troubleshooting guide

Warning: Switch off the engine and pull off the ignition cable before making any checks or adjustments.

Warning: If, after making an adjustment or repair to the engine, you let it run for a few minutes, remember that the exhaust and other parts will get hot. Do not touch these parts as these may burn you.

FAULT	POSSIBLE CAUSES	REMEDY
The unit does not operate smoothly and vibrates intensively	<ul style="list-style-type: none"> - Bolts loose - Spark plug defective 	<ul style="list-style-type: none"> - Check bolts - Replace spark plug
The engine does not start	<ul style="list-style-type: none"> - Throttle lever in wrong position - Spark plug defective - Fuel tank empty - Petrol fuel tap closed 	<ul style="list-style-type: none"> - Check setting - Replace spark plug - Top up fuel - Open petrol fuel tap
Engine does not run smoothly	<ul style="list-style-type: none"> - Air filter dirty - Spark plug soiled or defective - lack of engine oil 	<ul style="list-style-type: none"> - Clean the air filter - Clean or replace the spark plug
Drive power falls	<ul style="list-style-type: none"> - Clutch play too large - V-belt loose 	<ul style="list-style-type: none"> - Adjust clutch cable - Contact customer service (0151 649 1500)
The engine will not start or dies after a short period of time	<ul style="list-style-type: none"> - Spark plug foul - No fuel - Fuel Tap 'OFF' 	<ul style="list-style-type: none"> - Clean or replace spark plug (electrode spacing 0.6 mm) - Top up fuel - Turn Fuel Tap 'ON' (pull away from engine)

Please adhere to the following maintenance periods in order to ensure a failure-free operation.

Important! Fill in engine oil and fuel before starting up the engine for the first time.

(4-STROKE)	Before each use	After an operating period of 20 hours	After an operating period of 50 hours	After an operating period of 100 hours	After an operating period of 300 hours
Check the engine oil	X				
Change the engine oil		for the first time then every 100 hours		X	
Check the air filter	X				Change the filter element if necessary
Clean the air filter			X		
Clean the petrol filter				X	
Visual inspection of the unit	X				
Clean the spark plug			Distance: 0.6mm, Replace if necessary		
Check and readjust the carburetor's throttle valve					X*
Clean the cylinder head					X*
Set the valve clearance					X*

Important: The positions marked with "X*" should only be carried out by a repair agent.



Declaration of Conformity

- | | |
|---|--|
| <ul style="list-style-type: none"> <input type="checkbox"/> erklårt folgende Konformität gemäß EU-Richtlinie und Normen für Artikel <input type="checkbox"/> explains the following conformity according to EU directives and norms for the following product <input type="checkbox"/> déclare la conformité suivante selon la directive CE et les normes concernant l'article <input type="checkbox"/> dichiara la seguente conformità secondo la direttiva UE e le norme per l'articolo <input type="checkbox"/> verklaart de volgende overeenstemming conform EU richtlijn en normen voor het product <input type="checkbox"/> declara la siguiente conformidad a tenor de la directiva y normas de la UE para el artículo <input type="checkbox"/> declara a seguinte conformidade, de acordo com a directiva CE e normas para o artigo <input type="checkbox"/> attesterer følgende overensstemmelse i medfør af EU-direktiv samt standarder for artikel <input type="checkbox"/> förklarar följande överensstämmelse enl. EU-direktiv och standarder för artikeln <input type="checkbox"/> vakuuttaa, että tuote täyttää EU-direktiivin ja standardien vaatimukset <input type="checkbox"/> tõendab toote vastavust EL direktiivile ja standarditele <input type="checkbox"/> vydává následující prohlášení o shodě podle směrnice EU a norem pro výrobek <input type="checkbox"/> potrjuje sledečo skladnost s smernico EU in standardi za izdelek <input type="checkbox"/> vydáva nasledujúce prehlásenie o zhode podľa smernice EÚ a noriem pre výrobok <input type="checkbox"/> a cikkekhez az EU-irányvonal és Normák szerint a következő konformitást jelenti ki | <ul style="list-style-type: none"> <input type="checkbox"/> deklaruje zgodność wymienionego poniżej artykułu z następującymi normami na podstawie dyrektywy WE. <input type="checkbox"/> декларира съответното съответствие съгласно Директива на ЕС и норми за артикул <input type="checkbox"/> paskaidro šādu atbilstību ES direktīvai un standartiem <input type="checkbox"/> aribūšina šį atitikimą EU reikalavimams ir prekės normoms <input type="checkbox"/> declară următoarea conformitate conform directivei UE și normelor pentru articolul <input type="checkbox"/> δηλώνει την ακόλουθη συμμόρφωση σύμφωνα με την Οδηγία ΕΚ και τα πρότυπα για το προϊόν <input type="checkbox"/> potvrđuje sljedeću usklađenost prema smjernicama EU i normama za artikl <input type="checkbox"/> potvrđuje sljedeću usklađenost prema smjernicama EU i normama za artikl <input type="checkbox"/> potvrđuje sledeću usklađenost prema smernicama EZ i normama za artikal <input type="checkbox"/> следующим удостоверяется, что следующие продукты соответствуют директивам и нормам ЕС <input type="checkbox"/> проголошує про зазначену нижче відповідність виробу директивам та стандартам ЄС на виріб <input type="checkbox"/> ja izjavuva slednata soobrznost согласно EY-direktivata i normite za artikli <input type="checkbox"/> Ürünü ile ilgili AB direktifleri ve normları gereğince aşağıda açıklanan uygunluğu belirtir <input type="checkbox"/> erklærer følgende samsvar i henhold til EU-direktivet og standarder for artikkel <input type="checkbox"/> Lýsir uppfyllingu EU-reglna og annarra staðla vöru |
|---|--|

Petrol Tiller HQ-MT 3336 (Qualcast)

- | | |
|---|--|
| <input type="checkbox"/> 2009/105/EC | <input checked="" type="checkbox"/> 2006/42/EC |
| <input type="checkbox"/> 2006/95/EC | <input type="checkbox"/> Annex IV
Notified Body:
Notified Body No.:
Reg. No.: |
| <input type="checkbox"/> 2006/28/EC | |
| <input type="checkbox"/> 2005/32/EC | |
| <input checked="" type="checkbox"/> 2004/108/EC | <input type="checkbox"/> 2000/14/EC_2005/88/EC |
| <input type="checkbox"/> 2004/22/EC | <input type="checkbox"/> Annex V |
| <input type="checkbox"/> 1999/5/EC | <input type="checkbox"/> Annex VI
Noise: measured L _{WA} = dB (A); guaranteed L _{WA} = dB (A)
P = kW; L/Ø = cm
Notified Body: |
| <input type="checkbox"/> 97/23/EC | |
| <input type="checkbox"/> 90/396/EC | <input checked="" type="checkbox"/> 2004/26/EC
Emission No.: eIRL*97/68SA*2004/26*0097*00 |
| <input type="checkbox"/> 89/686/EC_96/58/EC | |

Standard references: EN 709; EN ISO 14982

Landau/Isar, den 30.06.2010

Weichselgartner/General Manager

Frank/Product-Management

First CE: 10
Art.-No.: 34.302.79 I.-No.: 11020
Subject to change without notice

Archive-File/Record: 3430279-12-4155050-10
Documents registrar: Mayn Robert
Wiesenweg 22, D-94405 Landau/Isar

PRODUCT GUARANTEE

This product is guaranteed against manufacturing defects for a period of



This product is guaranteed for twenty four months from the date of original purchase. Any defects that arises due to faulty materials or workmanship will either be replaced, refunded or repaired free of charge where possible during this period by the dealer from whom you purchased the unit.

The guarantee is subject to the following provisions:

- The guarantee does not cover accidental damage, misuse, cabinet parts, knobs or consumable items.
- The product must be correctly installed and operated in accordance with the instructions contained in this manual.
- It must be used solely for domestic purpose.
- The guarantee will be rendered invalided if the product is re-sold or has been damaged by inexpert repair.
- Specifications are subject to change without notice.
- The manufacture disclaims any liability for the incidental or consequential damages.
- The guarantee is in addition to, and does not diminish your statutory or legal rights.

Guarantor: Home Retail Group
AVEBURY MILTON KEYNES, MK9 2NW

For technical support and assistance or requests for spare parts and accessories please contact 0151 649 1500 between the following hours:
Mon - Thursday 8.45am - 5.00pm Friday 8.45am - 3.15pm

Helpline No. UK 0151 649 1500 / IRE 189 094 6244

Notes

Notes



QUALCAST

AFTER SALES SUPPORT

UK / IRELAND HELPLINE NO 0151 6491500
REP. IRELAND HELPLINE NO 1890 946244
WEB SUPPORT www.einhell-uk.co.uk

MODEL NUMBER: HQ-MT 3336
HOMEBASE ARTICLE NUMBER: 318775