



User Manual

FERREX® ELECTRIC HEDGE TRIMMER F-EHS 694-1



Original instructions

Great care has gone into the manufacture of this product and it should therefore provide you with years of good service when used properly. In the event of product failure within its intended use over the course of the first 3 years after date of purchase, we will remedy the problem as quickly as possible once it has been brought to our attention. In the unlikely event of such an occurrence, or if you require any information about the product, please contact us via our helpline support services, details of which are to be found both in this manual and on the product itself.



PRODUCED IN CHINA FOR:

ALDI STORES LTD. PO BOX 26, ATHERSTONE
WARWICKSHIRE, CV9 2SH.

ALDI STORES (IRELAND) LTD.
PO BOX 726, NAAS, CO. KILDARE.
www.aldi.com

AFTER SALES SUPPORT 804020

GB 0044 151 649 1500 IE 0044 1890 946 244

www.einhell.co.uk

MODEL: F-EHS 694-1 03/2021

3
YEAR
WARRANTY



Contents

- Package contents**..... 3
- Components 6
- General information**..... 7
- Reading and storing the user manual 7
- Proper use..... 7
- Explanation of symbols 7
- Safety** 8
- Signal symbol/word definitions..... 8
- General power tool safety warnings 9
- First use**..... 15
- Checking the hedge trimmer and package contents..... 15
- Preparations 15
- Operation**..... 16
- Switching on and off 16
- Cutting 16
- Cleaning** 17
- Maintenance and care**..... 18
- Storage** 18
- Troubleshooting**..... 19
- Technical data** 20
- Residual risks** 21
- Disposal**..... 21
- Disposing of the packaging 21
- Disposing of the hedge trimmer 21
- Declaration of conformity** 22

Package contents

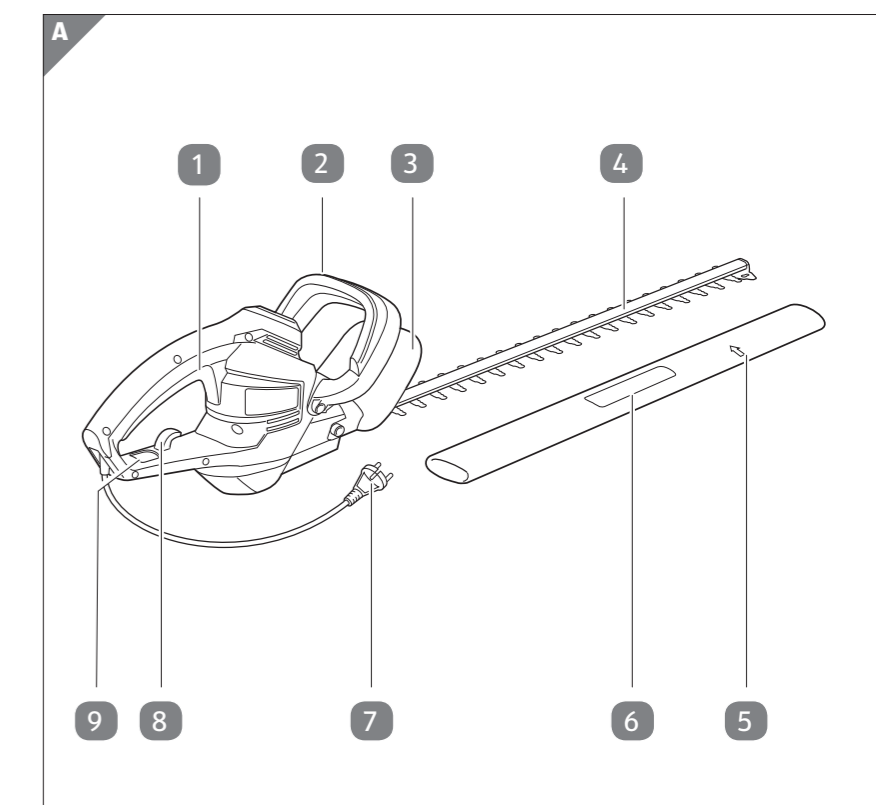

Package contents

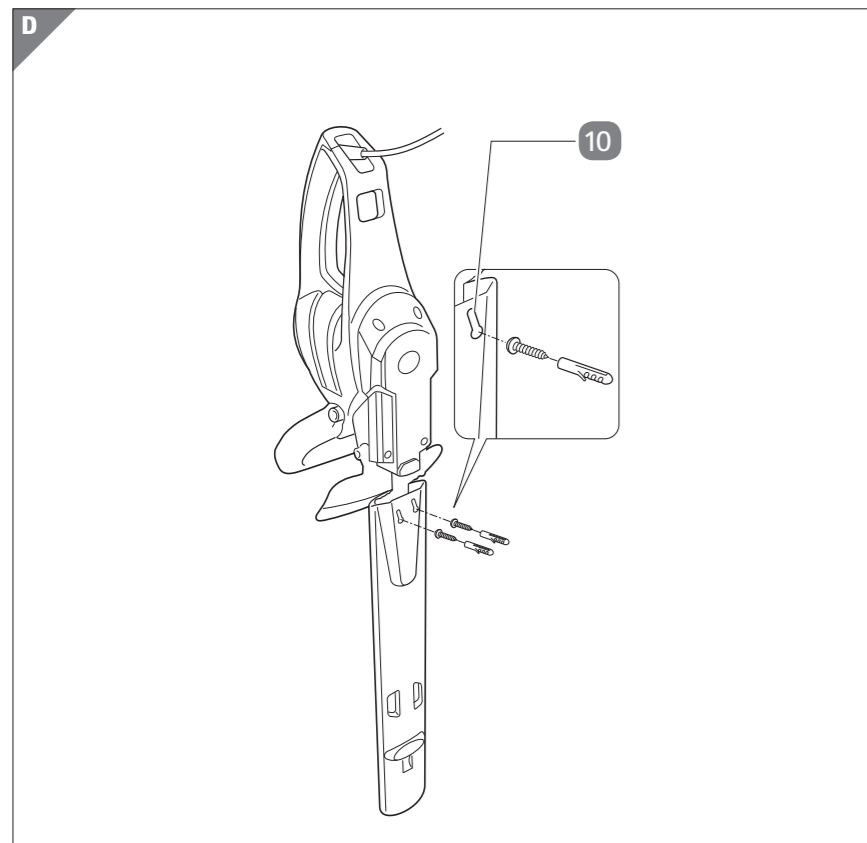
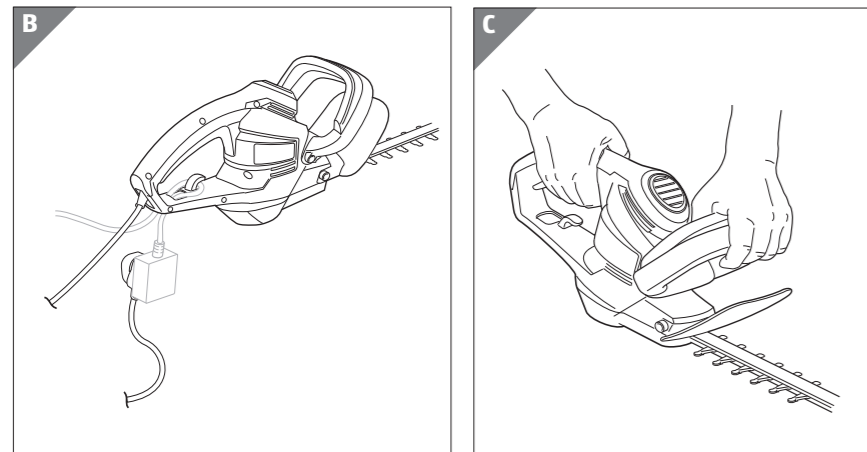

Package contents

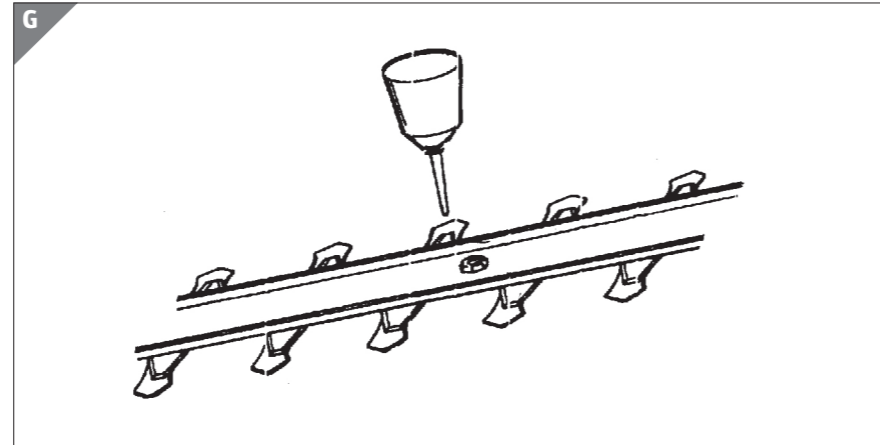
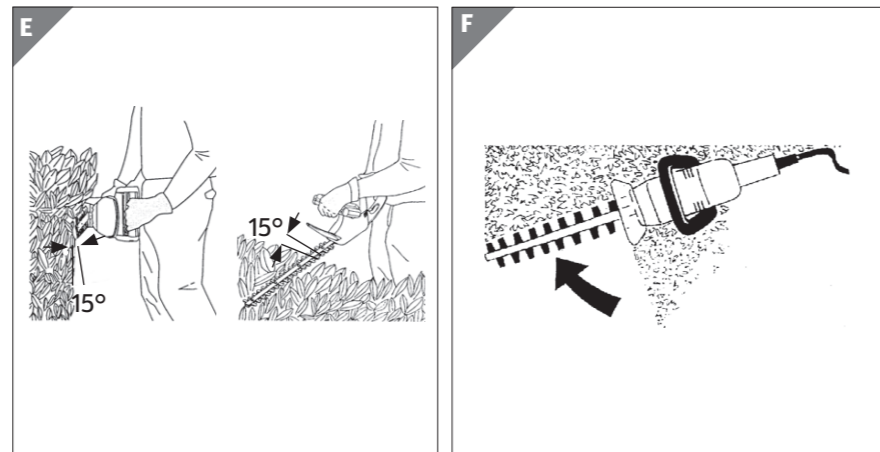

Package contents

Components

- 1 Handle with switch
- 2 Guide handle with switch
- 3 Transparent hand guard
- 4 Blade with double cutter
- 5 Locking mechanism for protective cap
- 6 Protective cap
- 7 Mains cord with mains plug
- 8 Cable strain relief
- 9 Cable feed-through
- 10 Bracket