

**Einhell®**

Ⓒ **Operating Instructions**  
**Petrol Water Pump**

**1**

**Art.-Nr.: 41.713.43**

**I.-Nr.: 11010**

**BG-PW 48**



Ⓢ Read and follow the operating instructions and safety information before using for the first time.

1

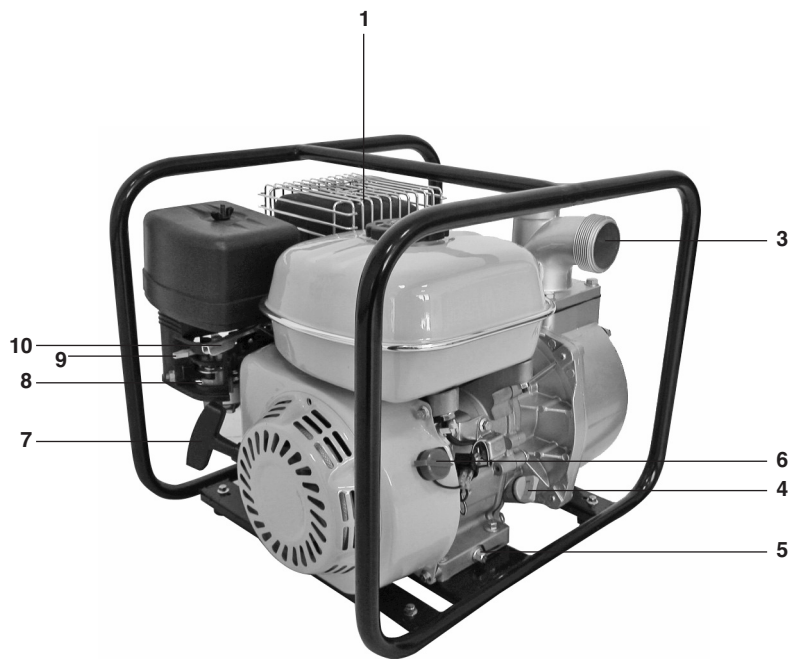

2

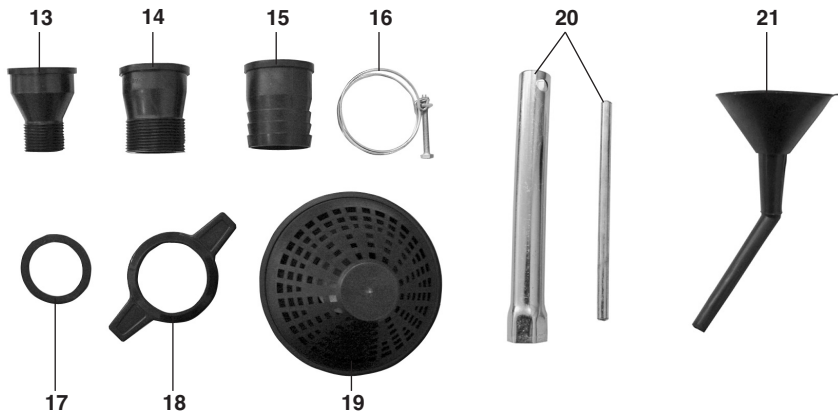

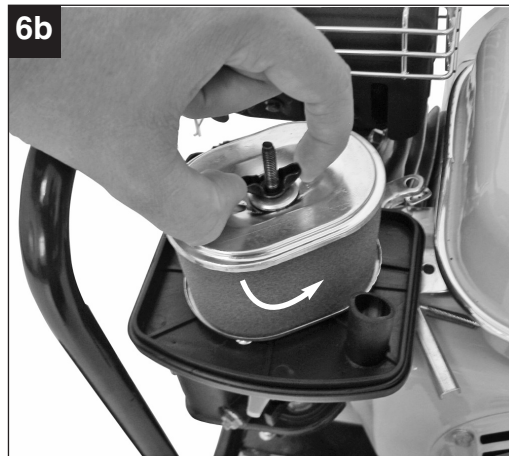
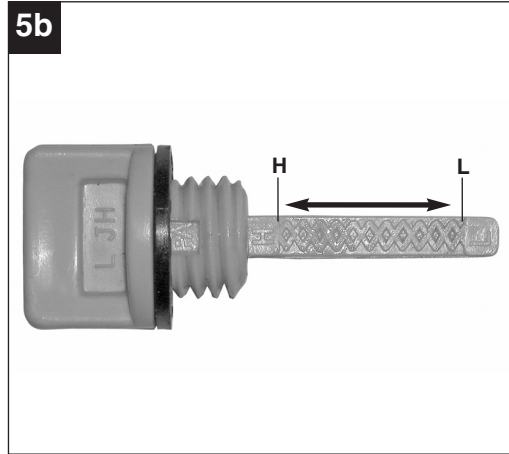
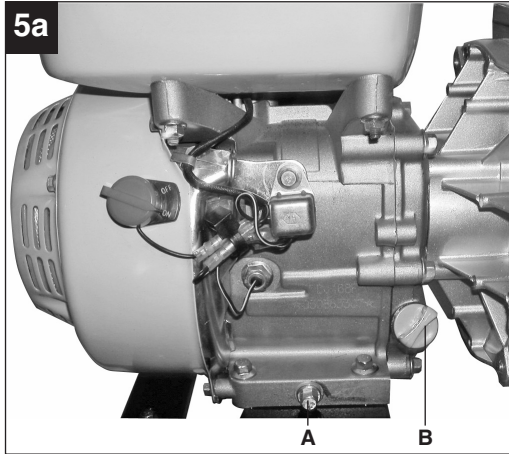
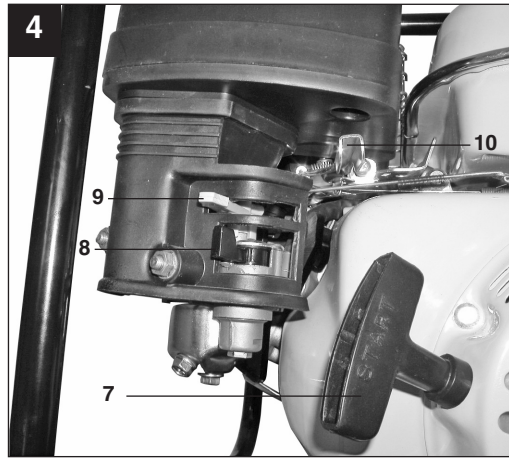
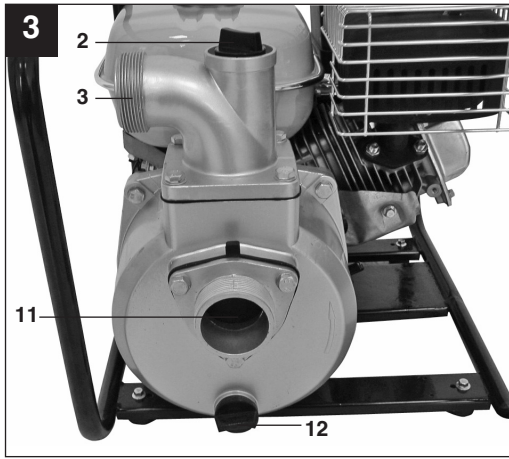

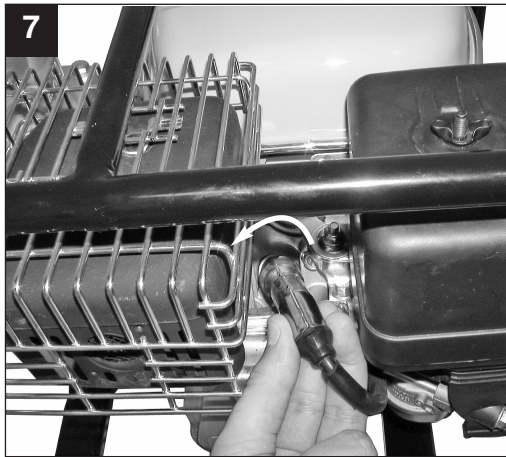

**GB**

## Table of contents

1. Safety regulations
2. Layout
3. Intended use
4. Technical data
5. Before putting the equipment into operation
6. Operation
7. Cleaning, maintenance, storage and ordering of spare parts
8. Disposal and recycling
9. Troubleshooting guide

**⚠ Important!**

When using equipment, a few safety precautions must be observed to avoid injuries and damage. Please read the complete operating manual with due care. Keep this manual in a safe place, so that the information is available at all times. If you give the equipment to any other person, give them these operating instructions as well. We accept no liability for damage or accidents which arise due to non-observance of these instructions and the safety information.

**1. Safety information**

Please refer to the booklet included in delivery for the safety instructions.

**⚠ CAUTION!****Read all safety regulations and instructions.**

Any errors made in following the safety regulations and instructions may result in an electric shock, fire and/or serious injury.

**Keep all safety regulations and instructions in a safe place for future use.**

**2. Layout (Fig. 1/4)**

- 1 Tank cover
- 2 Refilling nozzle with screw
- 3 Pressure connection
- 4 Oil filler plug
- 5 Oil drain plug
- 6 ON/OFF switch
- 7 Reversing starter
- 8 Petrol cock
- 9 Choke lever
- 10 Throttle control
- 11 Suction connection
- 12 Water emptying plug
- 13 2x Threaded connector 1" external thread
- 14 2x Threaded connector 1.25" external thread
- 15 2x Hose connector 2"
- 16 3x Hose clip
- 17 2x Seal
- 18 2x Union nut
- 19 Intake cage
- 20 Spark plug wrench
- 21 Oil filler funnel

**3. Proper use**

The machine is suitable for irrigating and watering landscaped areas, vegetable beds and gardens and for operating lawn sprinklers.

The water can be taken from ponds, streams, rainwater butts, rainwater cisterns and springs if an initial filter is fitted.

The maximum temperature of the fluid must not exceed +35°C if the machine is operated permanently.

Clean water (sweet water), rainwater and low concentrations of washing lye can be used as the transport medium. The machine must not be used to transport inflammable, gassing, explosive and aggressive fluids (such as petrol, acids, lyes, silo percolating juice, etc.) and fluids that contain abrasive substances (such as sand).

The machine is to be used only for its prescribed purpose. Any other use is deemed to be a case of misuse. The user / operator and not the manufacturer will be liable for any damage or injuries of any kind caused as a result of this.

Please note that our equipment has not been designed for use in commercial, trade or industrial applications. Our warranty will be voided if the machine is used in commercial, trade or industrial businesses or for equivalent purposes.

**GB**

#### 4. Technical data

Engine type:	4-stroke engine; air-cooled
Max. engine output:	4.8 kW / 6.5 bhp
Displacement:	196 cc
Idle speed of engine:	1500 rpm
Maximum engine speed:	3600 rpm
Fuel:	Regular unleaded petrol
Tank capacity:	3.6 l
Oil volume / type:	600 mL SAE#30
Spark plug:	L7TC
Max. intake head:	6 m
Max. pumping rate:	35000 l/h
Max. delivery head:	26 m
Max. pressure:	2.6 bar
Weight (with empty tank):	28 kg
Intake/Discharge connector:	2" hose connection 2" / 1.25" / 1" thread connector
$L_{WA}$ sound power level:	95 dB
$L_{pA}$ sound pressure level:	75 dB

#### 5. Before starting

As a basic principle, we recommend the use of a preliminary filter and a suction set with suction hose, suction strainer and non-return valve, in order to prevent long priming periods and unnecessary damage to the pump as a result of stones and solid foreign bodies.

##### 5.1 Preparing the machine

- Fill the engine with engine oil (see also point 7.2.1 Oil change).
- Fill the tank with petrol.
- Place the machine on a flat, firm surface.

#### 5.2 Connecting and routing the intake and discharge lines

- Connect the intake line to the intake connection (Figure 3 / Item 11) and the discharge line to the discharge connection (Figure 3 / Item 3).
- Position the intake line so that it rises from the water withdrawal point to the pump. It is essential that you do not route the intake line above the height of the pump. Air bubbles in the intake line will slow down and prevent the intake process.
- Install the intake and discharge lines in such a way that they do not exert any mechanical pressure on the pump.
- The intake valve should be low enough in the water to ensure that if the water level falls, the pump will not run dry.
- A leaking intake line will draw in air and therefore not draw in any water.
- Do not draw in any foreign bodies (sand, etc.). If necessary install an initial filter.

#### 6. Operation

The pump must be filled with the transport fluid at the filler neck (Figure 3 / Item 2) before the engine is started.

Note: We advise that you install a non-return valve in the intake line and fill it with water before you start the machine for the first time.

##### 6.1 Starting the engine

1. Set the On/Off switch (Figure 1 / Item 6) to "ON".
  2. Set the petrol cock (Figure 4 / Item 8) to the "ON" position.
  3. If the engine is cold, set the choke lever (Figure 4 / Item 9) to "Choke".
  4. Move the throttle lever (Figure 4 / Item 10) to the center position.
  5. Pull the starter cord (Figure 4 / Item 7) until the engine starts.
  6. When the engine has been running for approx. 30 seconds, move the choke lever to "Run".
- If the engine is warm, leave the choke lever in the "Run" position when starting.

Explanation of the positions of the throttle lever (Figure 4 / Item 10):

"Tortoise":  
Engine in idling

"Hare":  
Maximum delivery rate



## 6.2 Intake process

- During the priming process, the shut-off devices present in the pressure pipe (spray nozzles, valves etc.) must be completely open so that the air in the suction pipe can escape freely.
- Depending on the suction height and the air quantity in the suction pipe, the initial priming process can last for approx. 0.5 min. – 5 min. In the case of longer priming periods, top up again with water.
- If the pump is removed after use, it is essential that it is filled with water again the next time it is connected and started.

## 6.3 Stopping the engine

- Set the On/Off switch to "OFF".
- Close the petrol cock.

### Running-in period:

For the first 20 hours of operation, the motor must not be operated at full throttle for too long.

### Misfires, start-up difficulties:

Check whether

- fuel is flowing into the carburetor;
- the fuel filter is clean;
- the carburetor air valve is open;
- the air filter is clean;
- the spark plug is clean and the electrode gap is between 0.6 and 0.7mm.

## 7. Cleaning, maintenance, storage and ordering of spare parts

Disconnect the spark plug boot before doing any cleaning and maintenance work!

### 7.1 Cleaning

- Keep all safety devices, air vents and the motor housing free of dirt and dust as far as possible. Wipe the equipment with a clean cloth or blow it with compressed air at low pressure.
- We recommend that you clean the device immediately each time you have finished using it.
- Clean the equipment regularly with a moist cloth and some soft soap. Do not use cleaning agents or solvents; these could attack the plastic parts of the equipment. Ensure that no water can seep into the device.

## 7.2 Maintenance

In this connection, please also read the attached service information

### 7.2.1 Changing the oil

The engine oil is best changed when the engine is at working temperature

- Use only engine oil (10W40).
- Place the machine on a slightly inclined surface so that the oil drain plug is at the lower end (Figure 5a / Item A).
- Remove the oil filler screw (Figure 5a / Item B).
- Remove the oil drain plug and drain the warm engine oil into a suitable container.
- After all the oil has drained, screw in the oil drain plug and place the machine on a flat surface.
- Insert fresh engine oil up to the top mark on the oil dipstick (Figure 5b / Item H).

**Important.** Only inset the oil dipstick to check the oil level. Do not screw it in.

While the machine is working, the oil level must be between the two marks "L" and "H" (Figure 5b). Dispose of the waste oil properly.

### 7.2.2 Air filter

Clean the air filter at regular intervals, and replace it if necessary.

- Remove the screw from the air filter cover (Figure 6a)
- Remove the air filter cover.
- Remove the screw from the air filter element (Figure 6b)
- Remove the air filter element (Figure 6c).
- Clean the air filter by tapping it, blowing it out with compressed air or by washing it with soap suds. **Important.** Leave the air filter to dry before you refit it.
- Assemble in reverse order.

### 7.2.3 Spark plug

Clean the spark plug at regular intervals, and replace it if necessary. Set the electrode gap to 0.6 mm.

- Remove the spark plug boot by twisting it (Figure 7)
- Remove the spark plug using a spark plug wrench
- Clean the spark plug with a copper wire brush or fit a new one.
- Assemble in reverse order.

**GB**

### 7.3 Storage

- Rinse the pump thoroughly with water before lengthy periods of inactivity or winter storage.
- Close the petrol cock and allow the engine to run until it stops to empty the carburetor.
- Fill the tank fully to prevent rust formation.
- Remove the drain plug (Figure 3 / Item 12) and fully drain the pump housing.
- Store the machine in a dry place out of the reach of children.

### 7.4 Ordering replacement parts

Please quote the following data when ordering replacement parts:

- Type of machine
- Article number of the machine
- Identification number of the machine
- Replacement part number of the part required

For our latest prices and information please go to [www.isc-gmbh.info](http://www.isc-gmbh.info)

## 8. Disposal and recycling

The unit is supplied in packaging to prevent its being damaged in transit. This packaging is raw material and can therefore be reused or can be returned to the raw material system.

The unit and its accessories are made of various types of material, such as metal and plastic.

Defective components must be disposed of as special waste. Ask your dealer or your local council.

## 9. Troubleshooting

Fault	Cause	Remedy
Engine does not start	Spark plug fouled Air filter dirty No fuel in the tank Automatic oil cut-out has not responded	Clean or replace the spark plug Clean the air filter. Top up fuel. Check oil level, top up engine oil
Pump fails to prime	Intake valve not in the water No water in the pump chamber Air in the intake line Intake cage (intake valve) blocked Max. intake head exceeded	Place the intake valve in the water Fill the pump chamber with water through the filler neck Check the intake line for leaks and seal it if necessary. Clean intake cage Check intake head and reduce it if necessary
Insufficient pumping rate	Intake head too high Intake cage soiled Water level falling rapidly and intake line is out of the water- Pump performance reduced by deposits	Check intake head and reduce it if necessary Clean intake cage Place the intake line at a deeper level Clean pump

**Important.** The pump must not run dry.



# **GB** GUARANTEE CERTIFICATE

Dear Customer,

All of our products undergo strict quality checks to ensure that they reach you in perfect condition. In the unlikely event that your device develops a fault, please contact our service department at the address shown on this guarantee card. Of course, if you would prefer to call us then we are also happy to offer our assistance under the service number printed below. Please note the following terms under which guarantee claims can be made:

1. These guarantee terms cover additional guarantee rights and do not affect your statutory warranty rights. We do not charge you for this guarantee.
2. Our guarantee only covers problems caused by material or manufacturing defects, and it is restricted to the rectification of these defects or replacement of the device. Please note that our devices have not been designed for use in commercial, trade or industrial applications. Consequently, the guarantee is invalidated if the equipment is used in commercial, trade or industrial applications or for other equivalent activities. The following are also excluded from our guarantee: compensation for transport damage, damage caused by failure to comply with the installation/assembly instructions or damage caused by unprofessional installation, failure to comply with the operating instructions (e.g. connection to the wrong mains voltage or current type), misuse or inappropriate use (such as overloading of the device or use of non-approved tools or accessories), failure to comply with the maintenance and safety regulations, ingress of foreign bodies into the device (e.g. sand, stones or dust), effects of force or external influences (e.g. damage caused by the device being dropped) and normal wear resulting from proper operation of the device.

The guarantee is rendered null and void if any attempt is made to tamper with the device.

3. The guarantee is valid for a period of 2 years starting from the purchase date of the device. Guarantee claims should be submitted before the end of the guarantee period within two weeks of the defect being noticed. No guarantee claims will be accepted after the end of the guarantee period. The original guarantee period remains applicable to the device even if repairs are carried out or parts are replaced. In such cases, the work performed or parts fitted will not result in an extension of the guarantee period, and no new guarantee will become active for the work performed or parts fitted. This also applies when an on-site service is used.
4. In order to assert your guarantee claim, please send your defective device postage-free to the address shown below. Please enclose either the original or a copy of your sales receipt or another dated proof of purchase. Please keep your sales receipt in a safe place, as it is your proof of purchase. It would help us if you could describe the nature of the problem in as much detail as possible. If the defect is covered by our guarantee then your device will either be repaired immediately and returned to you, or we will send you a new device.

Of course, we are also happy offer a chargeable repair service for any defects which are not covered by the scope of this guarantee or for units which are no longer covered. To take advantage of this service, please send the device to our service address.

**EINHELL AUSTRALIA PTY LTD**  
6/166 Wellington Street  
Collingwood VIC 3066  
Australia  
Phone: 1300 922 271