

Original operating instructions  
**Cordless Drill**

 **bavaria**

**7**



**Art.-Nr.: 45.131.29**

**I.-Nr.: 11012**

**BCD 18 1h**

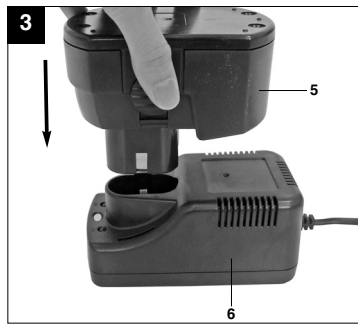
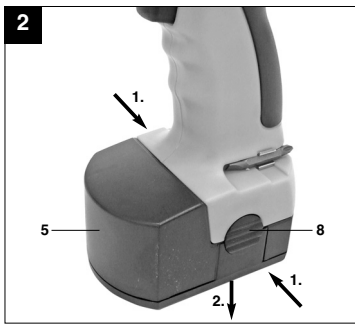

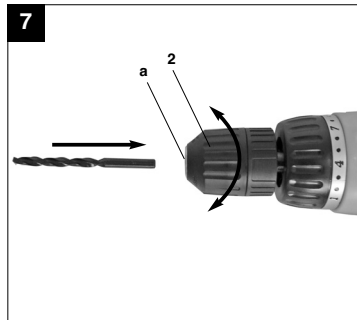
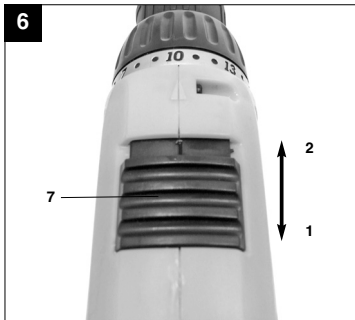
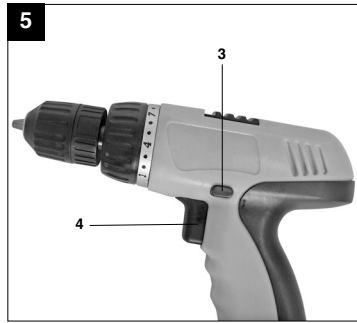

**⚠ Important!**

When using equipment, a few safety precautions must be observed to avoid injuries and damage. Please read the complete operating manual with due care. Keep this manual in a safe place, so that the information is available at all times. If you give the equipment to any other person, give them these operating instructions as well.  
We accept no liability for damage or accidents which arise due to non-observance of these instructions and the safety information.

**1. Safety information**

Please refer to the booklet included in delivery for the safety instructions.

**⚠ CAUTION!****Read all safety regulations and instructions.**

Any errors made in following the safety regulations and instructions may result in an electric shock, fire and/or serious injury.

**Keep all safety regulations and instructions in a safe place for future use.**

**2. Layout/ Items supplied (Fig. 1)****2.1 Layout**

1. Torque selector
2. Quick-change drill chuck
3. Changeover switch
4. ON/OFF switch
5. Battery pack
6. Battery charger
7. Selector switch for 1st/2nd gear
8. Pushlock button

**2.2 Items supplied**

- Open the packaging and take out the equipment with care.
- Remove the packaging material and any packaging and/or transportation braces (if available).
- Check to see if all items are supplied.
- Inspect the equipment and accessories for transport damage.
- If possible, please keep the packaging until the end of the guarantee period.

**IMPORTANT**

**The equipment and packaging material are not toys. Do not let children play with plastic bags, foils or small parts. There is a danger of swallowing or suffocating!**

- Cordless Drill
- Battery pack
- Battery charger
- Original operating instructions
- Safety instructions

**3. Proper use**

The cordless drill/screwdriver is designed for tightening and undoing screws, as well as for drilling in wood, metal and plastic.

The machine is to be used only for its prescribed purpose. Any other use is deemed to be a case of misuse. The user / operator and not the manufacturer will be liable for any damage or injuries of any kind caused as a result of this.

Please note that our equipment has not been designed for use in commercial, trade or industrial applications. Our warranty will be voided if the machine is used in commercial, trade or industrial businesses or for equivalent purposes.

**4. Technical data**

Voltage supply	18 V d.c.
Idling speed:	0-350/0-900 rpm
Torque settings:	19+1
Forward and reverse rotation	yes
Chuck clamping width	max. 10 mm
Battery charging voltage	18 V d.c.
Battery charging current	2.5 A
Mains voltage for charger	230 V ~ 50 Hz
Charging time:	max. 1 hours
Battery type:	NiCd
Weight	1.75 kg

**GB****Sound and vibration**

Sound and vibration values were measured in accordance with EN 60745.

$L_{pA}$ sound pressure level	60,5 dB(A)
$K_{pA}$ uncertainty	3 dB
$L_{WA}$ sound power level	71,5 dB(A)
$K_{WA}$ uncertainty	3 dB

**Wear ear-muffs.**

The impact of noise can cause damage to hearing.

Total vibration values (vector sum of three directions) determined in accordance with EN 60745.

**Drilling in concrete**

Vibration emission value  $a_{h1} \leq 2,5 \text{ m/s}^2$   
K uncertainty =  $1,5 \text{ m/s}^2$

**Screwing without hammer action**

Vibration emission value  $a_{h1} \leq 2,5 \text{ m/s}^2$   
K uncertainty =  $1,5 \text{ m/s}^2$

**Additional information for electric power tools****Warning!**

The specified vibration value was established in accordance with a standardized testing method. It may change according to how the electric equipment is used and may exceed the specified value in exceptional circumstances.

The specified vibration value can be used to compare the equipment with other electric power tools.

The specified vibration value can be used for initial assessment of a harmful effect.

**Keep the noise emissions and vibrations to a minimum.**

- Only use appliances which are in perfect working order.
- Service and clean the appliance regularly.
- Adapt your working style to suit the appliance.
- Do not overload the appliance.
- Have the appliance serviced whenever necessary.
- Switch the appliance off when it is not in use.
- Wear protective gloves.

**Residual risks**

**Even if you use this electric power tool in accordance with instructions, certain residual risks cannot be ruled out. The following hazards may arise in connection with the equipment's construction and layout:**

1. Lung damage if no suitable protective dust mask is used.
2. Damage to hearing if no suitable ear protection is used.
3. Health damage caused by hand-arm vibrations if the equipment is used over a prolonged period or is not properly guided and maintained.

**5. Before starting the equipment**

Be sure to read the following information before you use your cordless screwdriver for the first time:

1. Charge the battery pack only with the charger supplied.
2. Only ever use sharp drill bits and screwdriver bits which are suitable for the purpose and in faultless condition.
3. Always check for concealed electric cables and gas and water pipes when drilling and screwing in walls.

**6. Operation****6.1 Charging the LI battery pack (Fig. 2/3)**

1. Take the rechargeable battery pack out of the handle (Fig. 2), pressing the pushlock buttons at the side to do so.
2. Check that your mains voltage is the same as that marked on the rating plate of the battery charger. Plug the battery charger in the socket.
3. Insert the battery pack in the battery charger. The green LED will come on. Press the "SET" button to charge the battery pack. The red LED will come on to indicate that the battery pack is being charged. The green LED will come on to indicate that charging has been completed. The temperature of the battery pack may rise slightly during the charging operation. This is normal.

If the battery pack fails to become charged, please check

- whether there is voltage at the socket-outlet
- whether there is proper contact at the charging contacts on the charger.



If the battery still fails to become charged, please return

- the charger
  - the battery pack
- to our Customer Service Department.

To ensure that the battery pack provides long service, you should take care to recharge it promptly. You must recharge the battery pack when you notice that the power of the cordless screwdriver drops.

Never fully discharge the battery pack. This will cause it to develop a defect!

#### 6.2 Torque setting (Fig. 4 / Item 1)

The cordless screwdriver is fitted with a mechanical torque selector.

The torque for a specific size of screw is selected with the set-collar (1). The correct torque depends on several factors:

- on the type and hardness of material in question
- on the type and length screws used
- on the requirements needing to be met by the screwed joint.

The clutch disengages with a grating sound to indicate when the set torque is reached.

**Important! The tool must be at a standstill when you set the torque with the setting ring.**

#### 6.3 Drilling (Fig. 4 / Item 1)

For drilling purposes, move the set-collar to the last step „Drill“. In this setting the slip clutch is inactive. The maximum torque is available in drilling mode.

#### 6.4 Forward/Reverse switch (Fig. 5 / Item 3)

With the slide switch above the On/Off switch you can select the direction of rotation of the battery-powered drill/screwdriver and secure it against being switched on accidentally. You can choose between clockwise and anticlockwise rotation. To avoid causing damage to the gearing it is advisable to change the direction of rotation only when the tool is at a standstill. The On/Off switch is blocked when the slide switch is in centre position.

#### 6.5 On/Off switch (Fig. 5 / Item 4)

Infinitely variable speed control is possible with the On/Off switch. The further you press the switch, the higher the speed of the battery-powered drill/screwdriver.

#### 6.6 Changing over from 1st gear to 2nd gear (Fig. 6 / Item 7)

You can work at a higher or lower speed depending on the position of the selector switch. To avoid damaging the gear unit you should only change over gears when the tool has stopped.

#### 6.7 Changing the tool (Fig. 7)

**Important.** Set the changeover switch (3) to its centre position whenever you carry out any work (for example changing the tool, maintenance work, etc.) on the cordless screwdriver.

- Open the chuck (2). The chuck opening (a) must be large enough to hold the tool (drill bit or screwdriver bit).
- Select the suitable tool. Push the tool as far as possible into the chuck opening (a).
- Tighten the chuck (2) and then check that the tool is secure.

#### 6.8 Screwdriving

We recommend using self-centering screws (e.g. Torx screws, recessed head screws) designed for reliable working. Be sure to use a bit that matches the screw in shape and size. Set the torque, as described elsewhere in these operating instructions, to suit the size of screw.

### 7. Cleaning, maintenance and ordering of spare parts

Always pull out the mains power plug before starting any cleaning work.

#### 7.1 Cleaning

- Keep all safety devices, air vents and the motor housing free of dirt and dust as far as possible. Wipe the equipment with a clean cloth or blow it with compressed air at low pressure.
- We recommend that you clean the device immediately each time you have finished using it.
- Clean the equipment regularly with a moist cloth and some soft soap. Do not use cleaning agents or solvents; these could attack the plastic parts of the equipment. Ensure that no water can seep into the device.

#### 7.2 Maintenance

There are no parts inside the equipment which require additional maintenance.

**GB**

### 7.3 Ordering replacement parts

Please quote the following data when ordering replacement parts:

- Type of machine
- Article number of the machine
- Identification number of the machine
- Replacement part number of the part required

For our latest prices and information please call 1300 922 271

### 8. Disposal and recycling

The unit is supplied in packaging to prevent its being damaged in transit. This packaging is raw material and can therefore be reused or can be returned to the raw material system.

The unit and its accessories are made of various types of material, such as metal and plastic. Defective components must be disposed of as special waste. Ask your dealer or your local council.

### 9. Storage

Store the equipment and accessories out of children's reach in a dark and dry place at above freezing temperature. The ideal storage temperature is between 5 and 30 °C. Store the electric tool in its original packaging.

The guarantee provided in this Guarantee Certificate is given by Einhell Australia Pty Limited  
ACN 134 632 858 of 6/166 Wellington Street, Collingwood, Victoria (Telephone number 1300 922 271)  
(Einhell Express Guarantee).

## GUARANTEE CERTIFICATE

Dear Customer,

All of our products undergo strict quality checks. In the unlikely event that your device develops a fault, please contact our service department at the address shown on this guarantee certificate. Of course, if you would prefer to call us then we are also happy to offer our assistance under the service number printed below. Please note the following terms under which claims under the Einhell Express Guarantee can be made:

1. The benefits conferred by the Einhell Express Guarantee are in addition to all rights and remedies which you may be entitled to under the Australian Consumer Law, and any other statutory rights you may have under other applicable laws. This Einhell Express Guarantee does not exclude, restrict or modify any such rights or remedies.  
We do not charge you for the Einhell Express Guarantee.
2. Our goods come with guarantees that cannot be excluded under the Australian Consumer Law. You are entitled to a replacement or refund for a major failure and for compensation for any other reasonably foreseeable loss or damage. You are also entitled to have the goods repaired or replaced if the goods fail to be of acceptable quality and the failure does not amount to a major failure.
3. The Einhell Express Guarantee only covers problems caused by material or manufacturing defects, and our liability under the Einhell Express Guarantee is limited, at our discretion, to the rectification of these defects or replacement of the product. Please note that the product has not been designed for use in commercial, trade or industrial applications. Consequently, the Einhell Express Guarantee will not apply if the product is used in commercial, trade or industrial applications or for other equivalent activities.
4. The following are also excluded from the Einhell Express Guarantee: compensation for transport damage, damage caused by failure to comply with the installation/assembly instructions or damage caused by unprofessional installation, failure to comply with the operating instructions (e.g. connection to the wrong mains voltage or current type), misuse or inappropriate use (such as overloading of the product or use of non-approved tools or accessories), failure to comply with the maintenance and safety regulations, ingress of foreign bodies into the product (e.g. sand, stones or dust), effects of force or external influences (e.g. damage caused by the product being dropped) and normal wear resulting from proper operation of the product. The Einhell Express Guarantee will also not apply if any attempt is made to tamper with the product.
5. The Einhell Express Guarantee is valid for a period of 2 years starting from the purchase date of the product. Claims made under the Einhell Express Guarantee should be submitted before the end of this guarantee period and within two weeks of the defect being noticed. No claims under the Einhell Express Guarantee will be accepted if submitted after the end of this guarantee period. The original guarantee period remains applicable to the device even if repairs are carried out or parts are replaced. In such cases, the work performed or parts fitted will not result in an extension of the guarantee period for the Einhell Express Guarantee, and the Einhell Express Guarantee will not apply for the work performed or parts fitted. This also applies when an on-site service is used.
6. To make a claim under the Einhell Express Guarantee, please send the relevant product postage-free to the address shown below and enclose either the original or a copy of your sales receipt or another dated proof of purchase. It would help us if you could describe the nature of the problem in as much detail as possible. If the defect is covered by the Einhell Express Guarantee, your product will be repaired immediately and returned to you, or we will send you a new device (at our election).

Any costs incurred by you in making a claim under this Einhell Express Guarantee, unless specified otherwise in this guarantee certificate, must be borne by you.

Of course, we are also happy to offer a chargeable repair service for any defects which are not covered by the scope of the Einhell Express Guarantee or for products which are no longer covered by the Einhell Express Guarantee. To take advantage of this service, please send the product to our service address.

EINHELL AUSTRALIA PTY LTD  
6/166 Wellington Street  
Collingwood VIC 3066  
Australia  
Phone: 1300 922 271

EH 08/2012 (01)