

Original operating instructions  
Electric Router

**Einhell**<sup>®</sup>

7

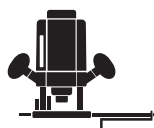

Art.-Nr.: 43.504.91

I.-Nr.: 01019

RT-RO **55**

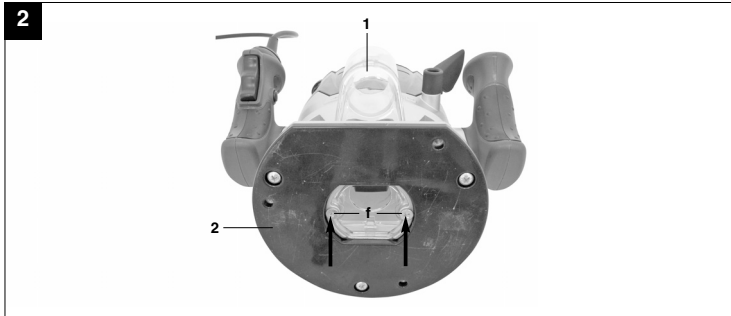
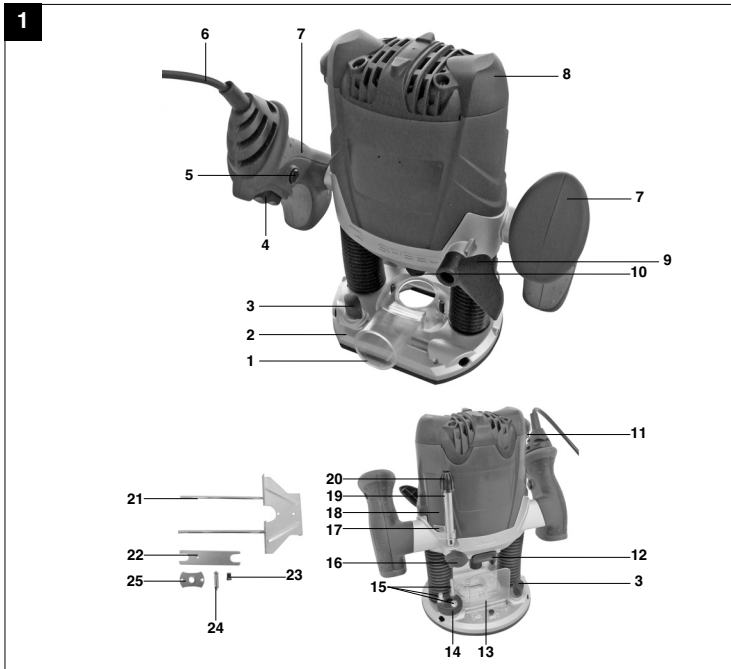

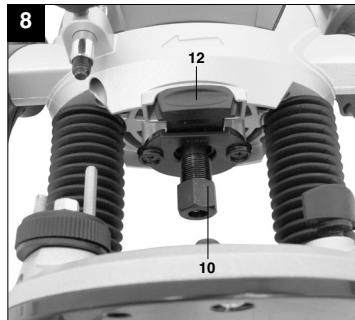
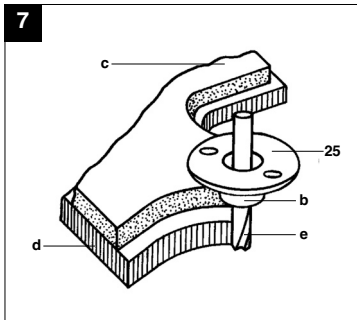
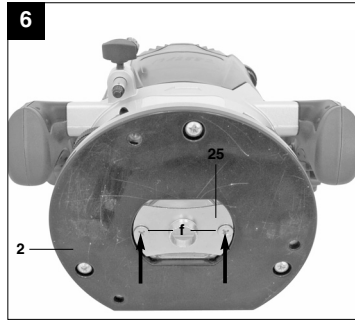
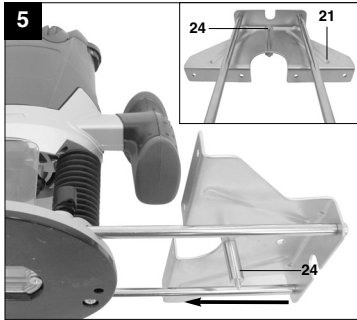
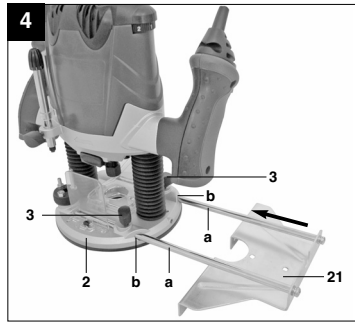
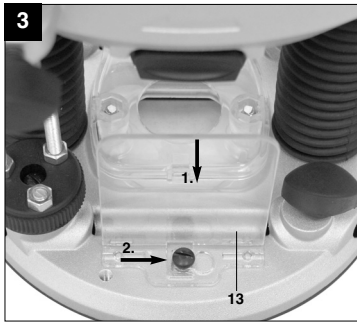

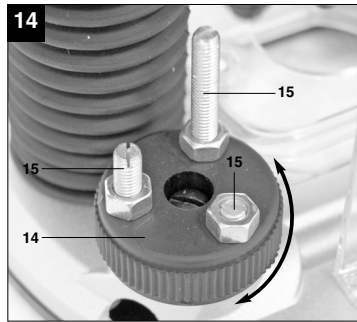
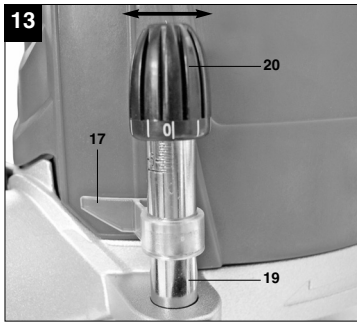
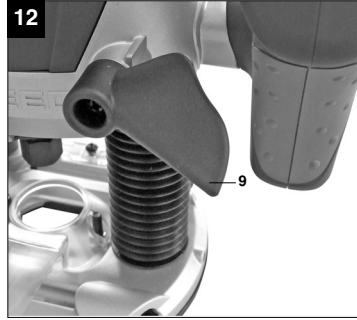
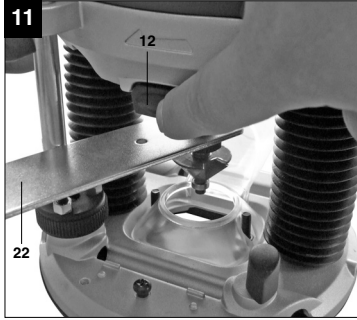
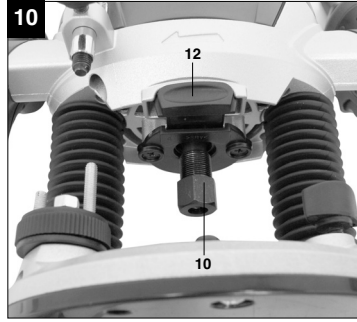
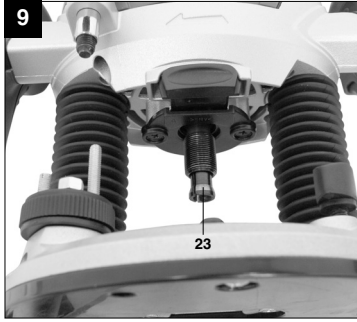

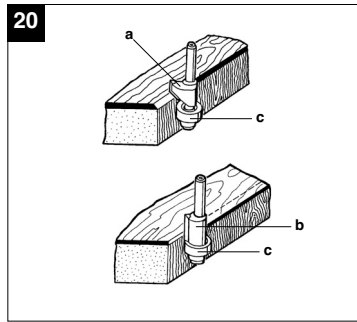
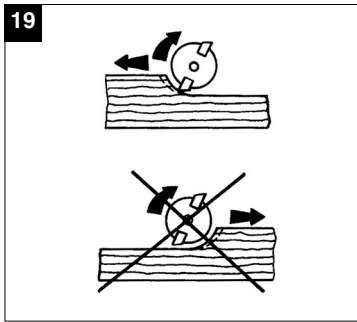
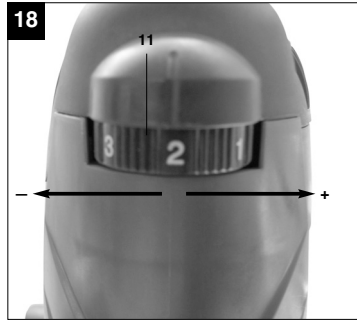
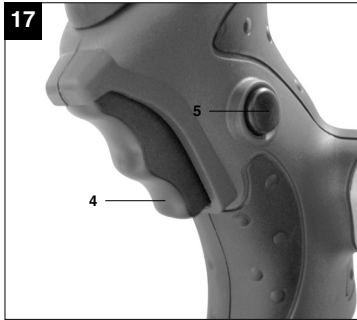
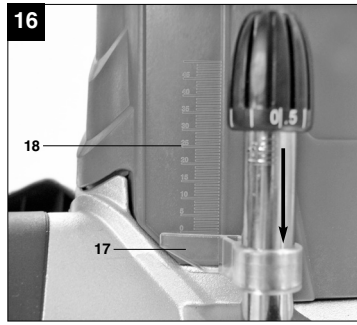
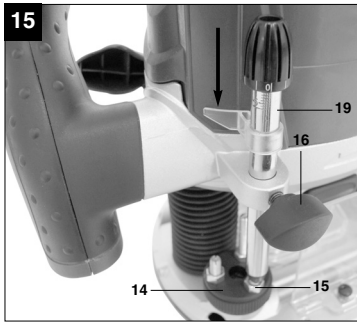

**GB**



"Caution - Read the operating instructions to reduce the risk of injury"



**Wear ear-muffs.**  
The impact of noise can cause damage to hearing.



**Wear a breathing mask.**  
Dust which is injurious to health can be generated when working on wood and other materials.  
Never use the device to work on any materials containing asbestos!



**Wear safety goggles.**  
Sparks generated during working or splinters, chips and dust emitted by the device can cause loss of sight.

**⚠ Important!**

When using equipment, a few safety precautions must be observed to avoid injuries and damage. Please read the complete operating manual with due care. Keep this manual in a safe place, so that the information is available at all times. If you give the equipment to any other person, give them these operating instructions as well.

We accept no liability for damage or accidents which arise due to non-observance of these instructions and the safety information.

**1. Safety information**

Please refer to the booklet included in delivery for the safety instructions.

**⚠ CAUTION!**

**Read all safety regulations and instructions.**

Any errors made in following the safety regulations and instructions may result in an electric shock, fire and/or serious injury.

**Keep all safety regulations and instructions in a safe place for future use.**

**2. Layout (Fig. 1)**

1. Extractor adapter
2. Routing shoe
3. Wing screw
4. ON/OFF switch
5. Safety lock-off
6. Power cable
7. Handle
8. Motor casing
9. Fixing handle
10. Clamp nut
11. Speed control
12. Spindle lock
13. Safety guard
14. Revolver end stop
15. End stop
16. Wing screw
17. Pointer
18. Scale
19. Depth stop
20. Fine adjuster
21. Parallel stop
22. Open-ended wrench
23. Clamp
24. Compass point
25. Guide sleeve

**3. Proper use**

The router is ideal for machining wood and plastic and also for cutting out knots, cutting grooves, removing recesses, copying curves and logos, etc. The router must not be used for machining metal, stone, etc.

The machine is to be used only for its prescribed purpose. Any other use is deemed to be a case of misuse. The user / operator and not the manufacturer will be liable for any damage or injuries of any kind caused as a result of this.

Please note that our equipment has not been designed for use in commercial, trade or industrial applications. Our warranty will be voided if the machine is used in commercial, trade or industrial businesses or for equivalent purposes.

**4. Technical data**

Mains voltage:	230 V ~ 50 Hz
Power input:	1200 W
Idling speed:	11,000 – 30,000 rpm
Stroke height:	55 mm (cutting depth)
Clamp	Ø 8 and Ø 6 mm
Max. for shaping router:	30 mm
Protection class:	II / □
Weight:	3.3 kg

**Sound and vibration**

Sound and vibration values were measured in accordance with EN 60745.

$L_{pA}$ sound pressure level	89.5 dB(A)
$K_{pA}$ uncertainty	3 dB
$L_{WA}$ sound power level	100.5 dB(A)
$K_{WA}$ uncertainty	3 dB

**Wear ear-muffs.**

The impact of noise can cause damage to hearing.

Total vibration values (vector sum of three directions) determined in accordance with EN 60745.

**Handles**

Vibration emission value  $a_h = 5.739 \text{ m/s}^2$   
K uncertainty = 1,5 m/s<sup>2</sup>

**GB****⚠ Important!**

The vibration value changes according to the area of application of the electric tool and may exceed the specified value in exceptional circumstances.

**Keep the noise emissions and vibrations to a minimum.**

- Only use appliances which are in perfect working order.
- Service and clean the appliance regularly.
- Adapt your working style to suit the appliance.
- Do not overload the appliance.
- Have the appliance serviced whenever necessary.
- Switch the appliance off when it is not in use.
- Wear protective gloves.

**5. Before starting the equipment**

Before you connect the equipment to the mains supply make sure that the data on the rating plate are identical to the mains data.

Always pull the power plug before making adjustments to the equipment.

All covers and safety devices have to be properly fitted before the machine is switched on.

**5.1 Extraction port assembly (Fig. 2/Item 1)****⚠ Important. For health and safety reasons it is imperative that you use a dust extractor.**

- Connect your router to the extraction port (1) of a vacuum cleaner or a dust extraction device. This will provide excellent dust extraction on the workpiece. The benefits are that you will protect both the equipment and your own health. Your work area will also be cleaner and safer.
- Dust created when working may be dangerous. Refer to the section entitled "Safety instructions".
- The vacuum cleaner you use for the extraction work must be suitable for the workpiece material. Use a special vacuum cleaner if you are handling harmful materials.
- Secure the extraction port (1) to the routing shoe (2) using the two countersunk screws (f).
- The extraction port can be connected to extractor units (vacuum cleaners) with a suction hose.
- The internal diameter of the suction port is 36 mm. Now fit a suction hose of the appropriate size to the suction port.

**5.2 Safety guard port assembly (Fig. 3/Item 13)**

Fit the safety guard (13) as shown in Fig. 3.

**5.3 Parallel stop assembly (Fig. 4/Item 21)**

- Push the guide shafts (a) of the parallel stop (21) into the holes (b) on the routing shoe (2).
- Set the parallel stop (21) to the required dimension and secure it in place with the wing screws (3).

**5.4 Compass point assembly (Fig. 5/Item 24)**

- You can cut circular areas using the compass point (24).
- Secure the compass point (24) to the parallel stop (21) as shown in the figure. Now fit the parallel stop (21) with the compass point (24) to the router. The assembly work is to be carried out as described in point 5.3, but the parallel stop (21) must be fitted at an angle of 180° so that the compass point (24) points downwards (Fig. 5).
- Set the required radius between the compass point (24) and cutter.
- Position the compass point (24) in the center of the circle you wish to route.

**5.5 Guide sleeve assembly (Fig. 6-7/Item 25)**

- Secure the guide sleeve (25) to the routing shoe (2) using the two countersunk screws (f).
- The guide sleeve (25) is guided along the template (c) using the guide ring (b).
- The workpiece (d) must be larger by the difference of "external edge of guide ring" and "external edge of router" (e) to obtain a precise copy.

**5.6 Fitting / Removing the cutting tool (Fig. 8-11)****⚠ Important. Pull out the power plug first.**

**⚠ Important. After working with the router, the cutting tool will remain very hot for a relatively long time.**

**⚠ Important. Cutters are very sharp. Wear protective gloves at all times when handling cutting tools.**

- Cutters with a shaft diameter of 6 mm and 8 mm may be fitted to this router. Most cutters are available in both sizes.
- You can use cutters made of the following materials:
  - **HSS** – Suitable for machining softwood
  - **TCT** – Suitable for machining hardwood, particle board, plastic and aluminum.
- Select the appropriate cutting tool for the job in hand.
- **When using the cutters for the first time:** Remove the plastic packaging from the cutter heads.



- Clean the nut, clamp and shaft of the cutter before fitting it.
- Press the spindle lock (12) and allow the spindle to engage by turning it at the same time.
- Undo the clamp nut (10) using the open-ended spanner (22).
- If necessary take the cutter you wish to remove out of the clamp (23).
- Select the appropriate cutting tool for the job in hand.
- Select the appropriate clamp for the cutter (23).
- Now fit the clamp (23) and nut (10) into the cutting spindle.
- Guide the cutter shaft into the clamp.
- Press and hold the spindle lock (12).
- Tighten the clamp nut (10) using the open-ended spanner (22).
- The cutter must be inserted at least 20 mm into the clamp (23).
- Before you start the electric router, check to ensure that the cutting tool is secure and runs smoothly.

### 5.7 Adjusting the end stops (Fig. 14/Item 15)

The height of the end stops (15) can be adjusted as required. To do this, undo the lock nut on the end stop (15) and turn it to the required stop height using a screwdriver.

**⚠ Important. Remove the setting and assembly tools before starting the machine**

## 6. Operation

- Never use a low quality or damaged cutter. Use only cutting tools with a shaft diameter of 6 mm or 8 mm. The cutters must also be designed for the appropriate idling speed.
- Secure the workpiece so that it cannot be thrown through the air as you work on it. Use clamps or a vise.
- Always guide the power cable away from the back of the tool.
- Never cut over metal parts, screws, nails etc.

### 6.1 ON/OFF switch (Fig. 17/Item 4)

Press the safety lock-off (5) and then press the ON/OFF switch (4) to switch on the machine.

Release the ON/OFF switch (4) to switch off the machine.

### 6.2 Speed control (Fig. 18 – Item 11)

The best speed depends on the material and the diameter of the cutter. Select a speed between 11,000 and 30,000 rpm using the speed control switch (11). You can choose from 6 different switch positions. The speeds in the various switch positions are as follows:

Switch position 1: approx. 11,000 rpm (minimum speed)

Switch position 2: approx. 16,000 rpm

Switch position 3: approx. 21,000 rpm

Switch position 4: approx. 25,000 rpm

Switch position 5: approx. 29,000 rpm

Switch position 6: approx. 30,000 rpm (maximum speed)

To increase the speed:

Move the speed control switch (11) in the plus direction.

To reduce the speed:

Move the speed control switch (11) in the minus direction.

### 6.3 Adjusting the routing depth (Fig. 12 – 16)

- Place the machine on the workpiece.
- Undo the wing screw (16) and fixing handle (9).
- Slowly move the machine downwards until the cutter makes contact with the workpiece.
- Tighten the fixing handle (9).
- Set the fine adjuster (20) to 0 as shown in Fig. 13.
- Adjust the revolver end stop (14) so that the depth stop (19) is above the end stop (15) set to the lowest height.
- Lower the depth stop (19) until it touches the end stop (15). Then tighten the wing screw (16).
- Set the pointer (17) to the zero point on the scale (18).
- Undo the wing screw (16). Push the depth stop (19) upwards until the pointer (17) points at the required cutting depth on the scale (18). Tighten the wing screw again.
- Test the setting by completing a test cut on a waste piece.
- Now you can carry out the final adjustment of the cutting depth. To do this turn the fine adjuster (20) to the required dimension.

Turn the fine adjuster (20) counter-clockwise: greater cutting depth

Turn the fine adjuster (20) clockwise: lower cutting depth

**GB**

Turning the fine adjuster (20) through one division corresponds to a change of cutting depth of 0.1 mm, one whole turn corresponds to 1 mm.

#### 6.4 Routing

- To avoid damage to the router, make sure there are no foreign objects attached to the workpiece.
- Connect the mains plug to a suitable socket.
- Hold the tool using both of its handles (7).
- Place the router on the workpiece.
- Set the cutting depth as described in point 6.3.
- Select the speed as described in point 6.2 and switch the machine on (see point 6.1).
- Test the machine settings using a piece of waste.
- Operate the tool at full speed. Only then should you lower the router to its working height and lock the machine with the locking grip (9).

**Cutting direction:** The cutting tool turns clockwise. To avoid accidents you must always cut against the direction in which the tool turns (Fig. 19).

**Feed speed:** It is very important to machine the workpiece at the correct feed speed. We recommend that before you machine the actual workpiece, you carry out several trial cuts on a waste piece of the same type. This will enable you to find the best working speed for the workpiece very easily.

#### Feed speed too low:

The cutter could heat up excessively. If you are cutting inflammable material such as wood, the workpiece could ignite.

#### Feed speed too high:

The cutter could be damaged. Cutting quality: Rough and uneven.

**Allow the cutter to come to a complete standstill before removing the workpiece or putting down the router.**

#### 6.5 Routing in stages

Depending on the hardness of the material you wish to cut and the cutting depth, it may be a good idea to proceed in stages.

- Adjust the end stops as described in point 5.7.
- If you wish to route in several stages, turn the end stop revolver (14) after you have set the cutting depth as described in point 6.3 so that the depth stop (19) is over the highest end stop (15).
- Now route in this setting. After completing the first routing operation, adjust the end stop revolver (14) so that the depth stop (19) is above middle end stop (15). Now complete a routing

operation in this setting as well.

- Now set the lowest end stop (15) and finish the routing.

#### 6.6 Routing circles with the compass point (24)

Proceed as follows to route circles around a centre point:

- Fit and adjust the compass point (24) as described in point 5.4.
- Place the compass point (24) on the centre point of the circle you wish to route and apply pressure to it.
- Complete the routing operation as described in point 6.4.

#### 6.7 Routing with the parallel stop (21)

Proceed as follows to route along a straight outer edge of a workpiece:

- Fit the parallel stop (24) as described in point 5.3.
- Guide the parallel stop (24) along the outer edge of the workpiece.
- Complete the routing operation as described in point 6.4.

#### 6.8 Free-hand routing

The router can also be operated without any guide rods. You can use it for freehand routing for creative work such as the production of logos.

- Use a very flat cutter setting for this purpose.
- Check the direction in which the cutter is turning as you machine the workpiece (Fig. 19).

#### 6.9 Shape and edge cutting (Fig. 20)

- Special cutters with a guide ring may be used for cutting shapes (a) and edges (b).
- Fit the cutter.
- Carefully guide the machine on to the workpiece.
- Guide the guide journal or ball bearing (c) along the workpiece with gentle pressure.

#### ⚠ Important:

**For deep cuts, carry out the work in several steps according to the material in question.**

**Hold the router in two hands when carrying out all cutting work.**

## 7. Replacing the power cable

If the power cable for this equipment is damaged, it must be replaced by the manufacturer or its after-sales service or similarly trained personnel to avoid danger.

## 8. Cleaning, maintenance and ordering of spare parts

Always pull out the mains power plug before starting any cleaning work.

### 8.1 Cleaning

- Keep all safety devices, air vents and the motor housing free of dirt and dust as far as possible. Wipe the equipment with a clean cloth or blow it with compressed air at low pressure.
- We recommend that you clean the device immediately each time you have finished using it.
- Clean the equipment regularly with a moist cloth and some soft soap. Do not use cleaning agents or solvents; these could attack the plastic parts of the equipment. Ensure that no water can seep into the device.

### 8.2 Carbon brushes

In case of excessive sparking, have the carbon brushes checked only by a qualified electrician. Important! The carbon brushes should not be replaced by anyone but a qualified electrician.

### 8.3 Maintenance

There are no parts inside the equipment which require additional maintenance.

### 8.4 Ordering replacement parts

Please quote the following data when ordering replacement parts:

- Type of machine
- Article number of the machine
- Identification number of the machine
- Replacement part number of the part required

For our latest prices and information please go to [www.isc-gmbh.info](http://www.isc-gmbh.info)

## 9. Disposal and recycling

The unit is supplied in packaging to prevent its being damaged in transit. This packaging is raw material and can therefore be reused or can be returned to the raw material system.

The unit and its accessories are made of various types of material, such as metal and plastic. Defective components must be disposed of as special waste. Ask your dealer or your local council.



The reprinting or reproduction by any other means, in whole or in part, of documentation and papers accompanying products is permitted only with the express consent of ISC GmbH.

Technical changes subject to change

# **GUARANTEE CERTIFICATE**

## Dear Customer,

All of our products undergo strict quality checks to ensure that they reach you in perfect condition. In the unlikely event that your device develops a fault, please contact our service department at the address shown on this guarantee card. Of course, if you would prefer to call us then we are also happy to offer our assistance under the service number printed below. Please note the following terms under which guarantee claims can be made:

1. These guarantee terms cover additional guarantee rights and do not affect your statutory warranty rights. We do not charge you for this guarantee.
2. Our guarantee only covers problems caused by material or manufacturing defects, and it is restricted to the rectification of these defects or replacement of the device. Please note that our devices have not been designed for use in commercial, trade or industrial applications. Consequently, the guarantee is invalidated if the equipment is used in commercial, trade or industrial applications or for other equivalent activities. The following are also excluded from our guarantee: compensation for transport damage, damage caused by failure to comply with the installation/assembly instructions or damage caused by unprofessional installation, failure to comply with the operating instructions (e.g. connection to the wrong mains voltage or current type), misuse or inappropriate use (such as overloading of the device or use of non-approved tools or accessories), failure to comply with the maintenance and safety regulations, ingress of foreign bodies into the device (e.g. sand, stones or dust), effects of force or external influences (e.g. damage caused by the device being dropped) and normal wear resulting from proper operation of the device. This applies in particular to rechargeable batteries for which we nevertheless issue a guarantee period of 12 months.  
  
The guarantee is rendered null and void if any attempt is made to tamper with the device.
3. The guarantee is valid for a period of 2 years starting from the purchase date of the device. Guarantee claims should be submitted before the end of the guarantee period within two weeks of the defect being noticed. No guarantee claims will be accepted after the end of the guarantee period. The original guarantee period remains applicable to the device even if repairs are carried out or parts are replaced. In such cases, the work performed or parts fitted will not result in an extension of the guarantee period, and no new guarantee will become active for the work performed or parts fitted. This also applies when an on-site service is used.
4. In order to assert your guarantee claim, please send your defective device postage-free to the address shown below. Please enclose either the original or a copy of your sales receipt or another dated proof of purchase. Please keep your sales receipt in a safe place, as it is your proof of purchase. It would help us if you could describe the nature of the problem in as much detail as possible. If the defect is covered by our guarantee then your device will either be repaired immediately and returned to you, or we will send you a new device.

Of course, we are also happy offer a chargeable repair service for any defects which are not covered by the scope of this guarantee or for units which are no longer covered. To take advantage of this service, please send the device to our service address.

Poweron Imports Limited  
17 Lorian Place  
East Tamaki  
Manukau City 2161  
Auckland  
Telephone (09) 2746950