

Universal Mitre Saw UKS 355

Art.-No.: **45.031.10**

Bar code: **4006825455052**

Sales unit: **1 pc**

The UKS 355 can be used for fast, tidy and precise separation of iron, aluminium, brass or wood. Due to the carbide tipped saw blade cooling or greasing is not necessary. Furthermore there are scarcely no sparking formation because of the slow idle speed. Due to the spindle lock an easy change of cutting discs is guaranteed. The saw is equipped with a vice, tiltable from 0° to 45° for safe clamping of the work pieces. The long-life motor offers a high torque at a low speed.

Features:

- Transparent view guard (1)
- Carbide tipped saw blade (2)
- Machine vice (3)

Technical data:

- Mains: 230 V ~ 50 Hz
- Power: 2300 watts
- Idle speed n_0 : 1300 min^{-1}
- Carbide tipped saw blade: \varnothing 355 mm x \varnothing 30 mm
- Number of teeth: 72
- Mitre cut: 0° - 45°
- Cutting capacity at 90°:
 - round: \varnothing 120 mm
 - rectangular: 100 x 190 mm
 - quadratic: 100 x 100 mm
 - angular: 95 x 95 mm
- Cutting capacity at 45°:
 - round: \varnothing 80 mm
 - rectangular: 105 x 80 mm
 - quadratic: 80 x 80 mm
 - angular: 60 x 60 mm
- Weight: 27 kg
- Packing dimensions: 600 x 395 x 465 mm

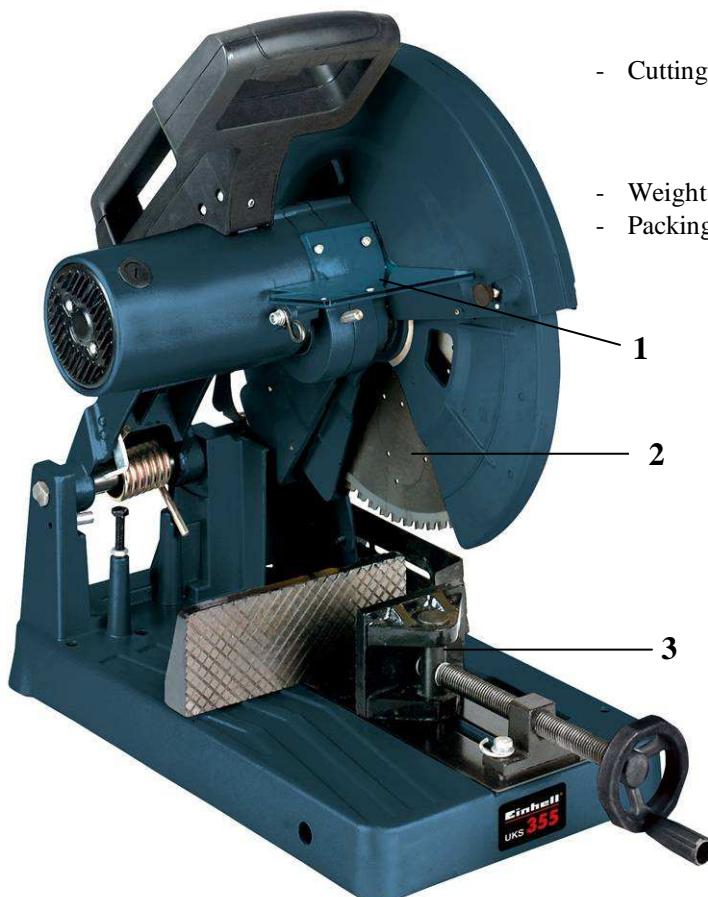

As special accessory available:

Saw blade
 \varnothing 355 x \varnothing 30 x 2,7 mm

Art.-No.: **43.111.16**
Bar code: **4006825515916**

Abbildungen können nicht im Serien-Lieferumfang enthaltenes Zubehör darstellen / Illustrations can contain accessories, which are not included in standard extent of delivery.

Abbildungen ähnlich, produktionsbedingte Abweichung vorbehalten / Illustration similar (in design), production-wise modifications reserved
File: S:\shared-pool\Product-Documentation\T-Produktbeschreibung\60\Originale_Englisch_PA04\4503110_01015.doc

Erstelldatum / create date: 11.08.2005 9:35

Aktualisiert / up dated: 08.02.2006