



SHZ 500-2 Electric Hoist

Art.-No. 22.555.15

- The start button is equipped with an emergency-cut-off button. This device guarantees a safe cut-off.
- The start button is designed in insulation class II (safety insulated).
- A forcibly actuated end switch assures that the hoist will safely be cut-off (roll up and roll off).
- Also in case of a defect on the pressure spring (i. e. rupture of the wire) stopping of the load is assured.
- The brake will be activated in case of power failure in the motor.
- The non-twisting steel rope prevents twisting of the loads during the lifting motion.
- The load hook with additional safety latch: This added latch prevents an unintended loosening of the load suspension device.
- The overload protection prevents the motor from overheating.

Features

- Fastening with 2 double clamps (1)
- Motor with thermal cut-off (2)
- Control switch with emergency button (3)
- 12 m steel wire rope (non-twisting, Ø 4.2 mm) (4)
- Deflection pulley with payload hook (5)
- Automatic load brake

Technical Data

- Payload: 250 kg without pulley
500 kg with pulley
- Lifting height: 11.5 m without pulley
5.7 m with pulley
- Mains: 230 V ~ 50 Hz
- Power: 900 W S3 25 %
- Rope speed: without pulley: 8 m/min
with pulley: 4 m/min
- Net weight: 17.2 kg
- Gross weight: 17.6 kg
- Packing dimensions: 400 x 155 x 245 mm
- Bar code: 4006825 555714
- Sales unit: 2 pcs

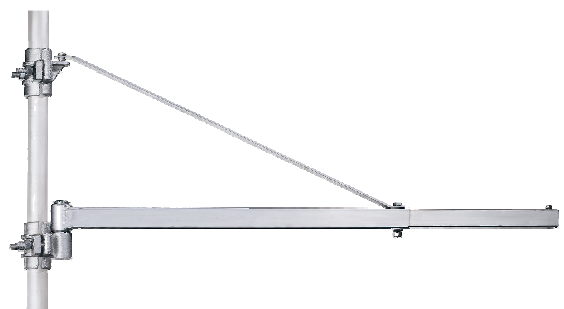
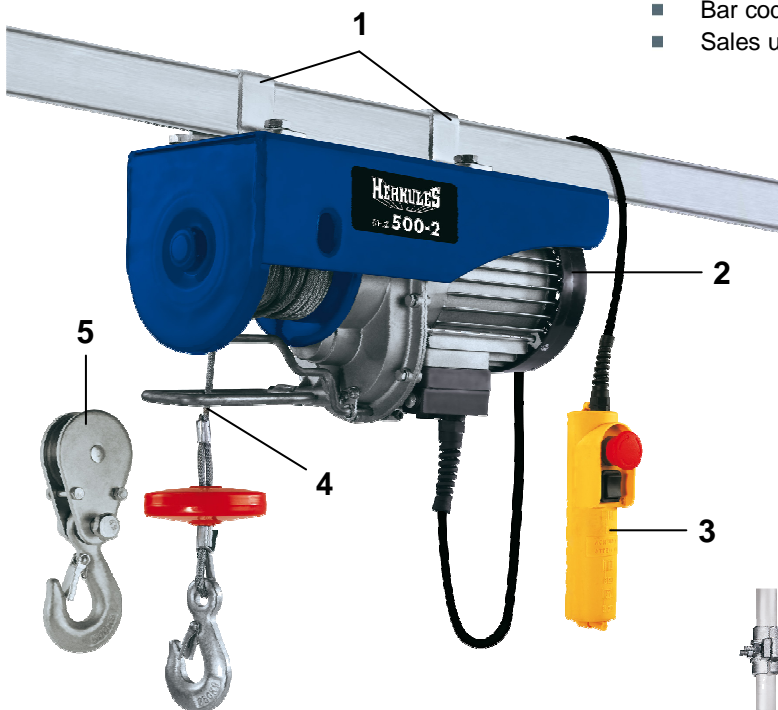

As special accessory available:

Hoist lever arm GT-SA 1200 Art.-No.: 22.553.98
Bar code: 4006825 540017