

GARDENLINE®

Garden Spreader

Operating Instructions - User Guide

After Sales Support

Now you have purchased a Gardenline® product you can rest assured in the knowledge that as well as your 3 year parts and labour guarantee you have the added peace of mind of dedicated helplines and web support.

AFTER SALES SUPPORT

  0151 649 1500  www.einhell.co.uk
 1890 946 244

MODEL: GLS 12



Contents

- 1 Welcome
- 2 Parts List
- 3 Instructions
- 4 Other useful information
- 5 Warranty Card

Welcome

1

Congratulations!

You have made an excellent choice with the purchase of this quality Gardenline® product.

By doing so you now have the assurance and peace of mind which comes from purchasing a product that has been manufactured to the highest standards of performance and safety, supported by the high quality standards of ALDI.

We want you to be completely satisfied with your purchase so this Gardenline® product is backed by a comprehensive manufacturer's 3 year warranty and an outstanding after sales service through our dedicated Helpline.

We hope you will enjoy using your purchase for many years to come.

If you require technical support or in the unlikely event that your purchase is faulty please telephone our Helpline for immediate assistance. Faulty product claims made within the 3 year warranty period will be repaired or replaced free of charge provided that you have satisfactory proof of purchase (keep your till receipt safe!). This does not affect your statutory rights. However, be aware that the warranty will become null and void if the product is found to have been deliberately damaged, misused or disassembled.

2



3



Layout (see Fig. 1)

- 1 Push bar
- 2 Adjustment lever for setting the spreading volume
- 3 Spreader tank
- 4 Wheel
- 5 Foot
- 6 Push bar

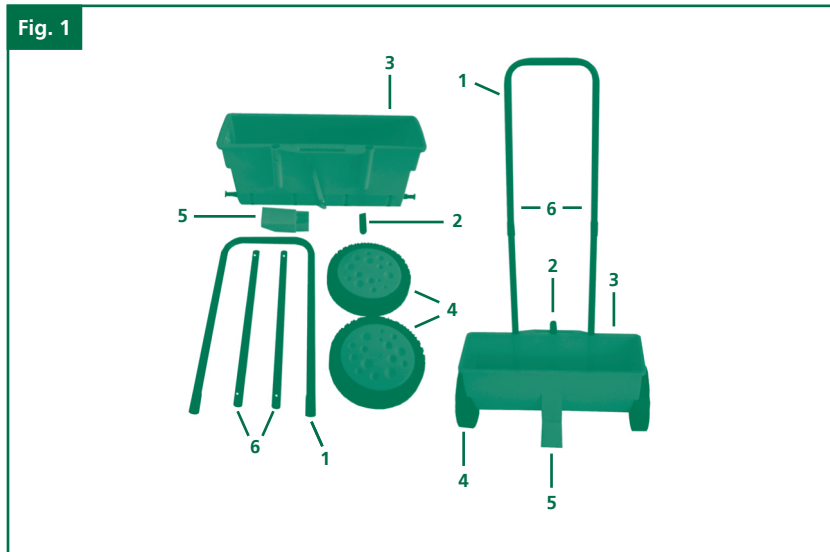

Assembly

- Push bar
 - Fit the push rods into the spreader tank (Fig. 2).
 - Fit the push bar on to the push rods (Fig. 3).
- Adjustment lever
 - Fit the adjustment lever grip (Fig.1/ Item 2) to the adjustment lever (Fig. 4/ Item A).

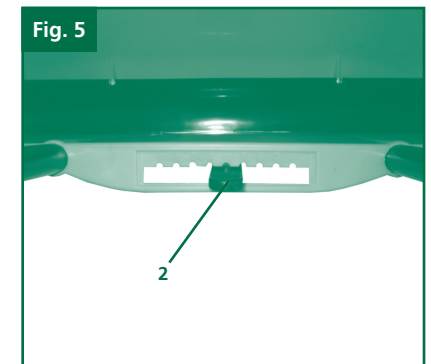
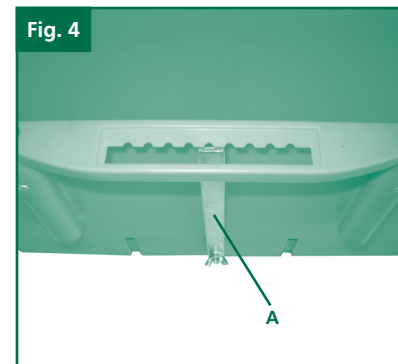
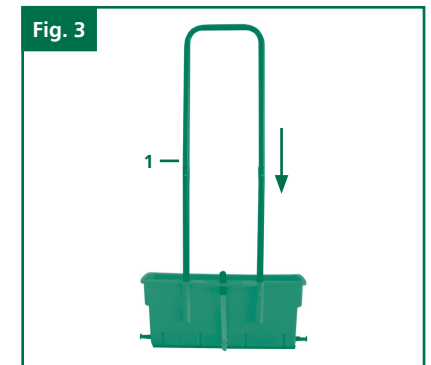
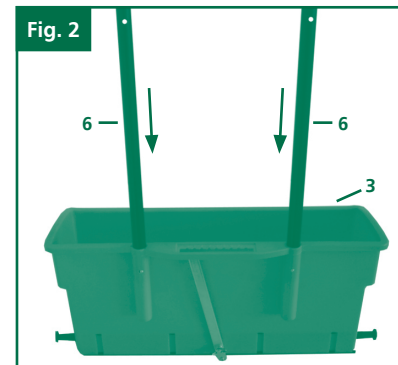

Assembly - continued

- **Foot**
 - Remove the screw (Fig. 6 / Item B).
 - Insert the foot (Fig. 7 / Item 5) and secure it.
- **Wheels**
 - Take the wheel caps off the wheels (Fig. 8).
 - Remove the screws (Fig. 9 / Item E) (on both sides).
 - Attach the wheels (Fig. 10 / Item D) and secure them.
 - Fit the wheel caps.

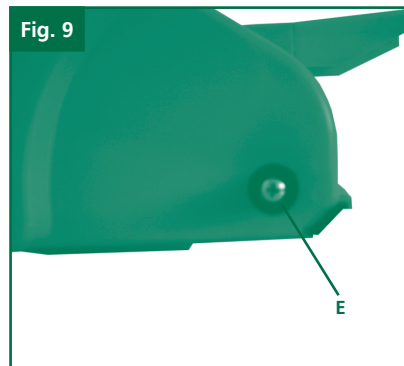
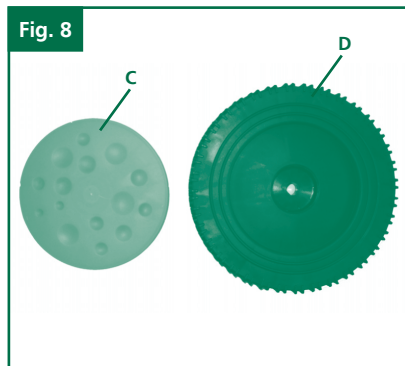
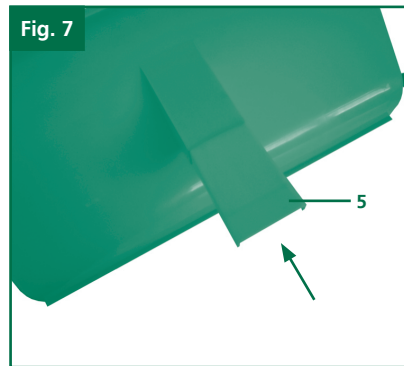
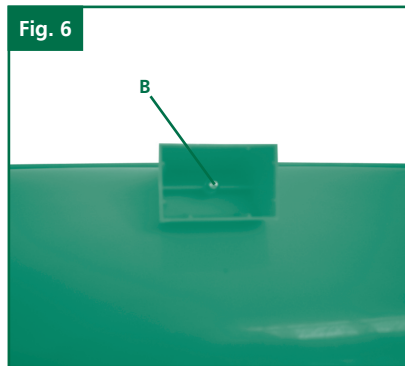

Operation

- **Insert spreader material**

IMPORTANT!
Before inserting the material, always set the adjustment lever (Fig. 5 / Item 2) to "0".

- **Recommended spreader settings**
 - Select the setting to suit the types of fertilizer or sand and salt.

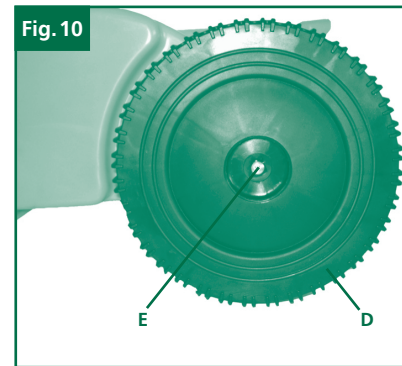

Other useful information

Re-ordering replacement parts

Please quote the following data when ordering replacement parts:

- Type of machine (GLS 12)
- Article number of the machine (34.152.37)
- Identification number of the machine (11012)
- Replacement part number of the part required

For our latest prices and information please go to www.einhell.co.uk



Garden Spreader

IMPORTANT!
KEEP THIS FORM SAFE: Only complete and return this form to the address below in the unlikely event of a warranty claim, if you are requested by the manufacturer to return the item for replacement. Then please complete this form and send it together with your receipt (proof of purchase) to the address below.

Your details:

Name _____

Address _____

 _____ Email _____

Date of purchase* _____

*We recommend you keep the receipt with this warranty card

Location of purchase _____

Description of malfunction:

Return your completed warranty card to:

Einhell UK Ltd
Unit 5 Morpeth Wharf
Twelve Quays
Wirral
CH41 1LF
England

www.einhell.co.uk/warranty

AFTER SALES SUPPORT

  0151 649 1500
 1890 946 244  www.einhell.co.uk

MODEL: GLS 12

Monday to Thursday 8:45am - 5pm,
Friday 8:45am - 3pm. Calls cost 10p
per minute from a landline, calls from
mobiles may vary.

3
YEAR WARRANTY

