

Original operating instructions
Electric Tiller



7



Art.-Nr.: 34.310.13

I.-Nr.: 11020

EBH **750**

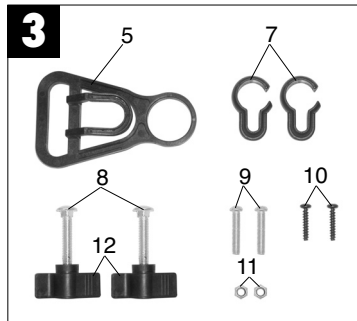
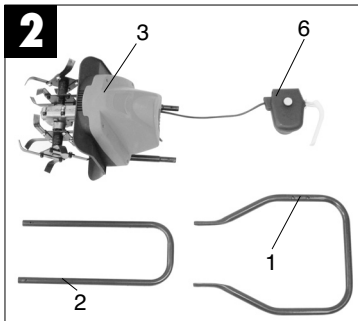
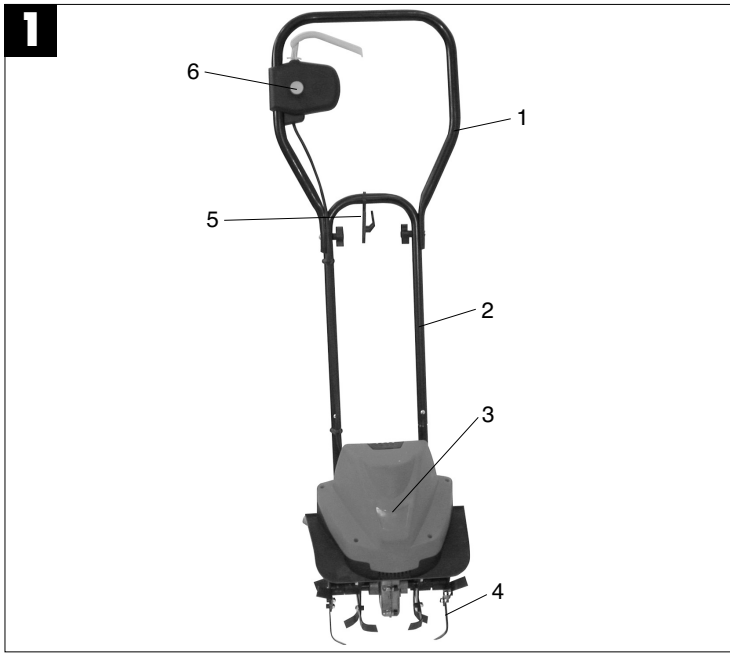

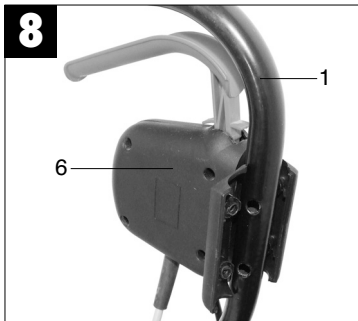
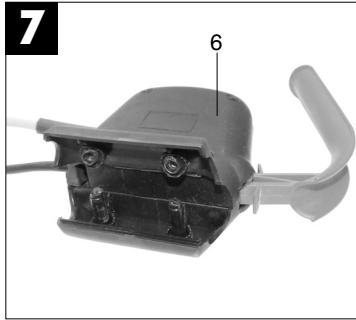
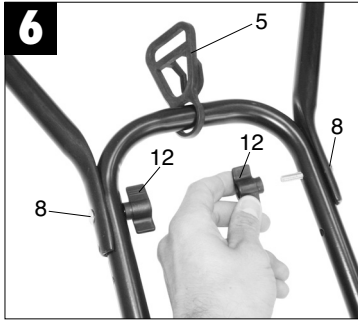
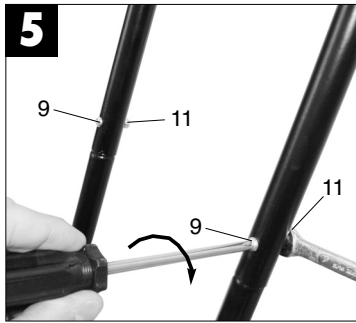
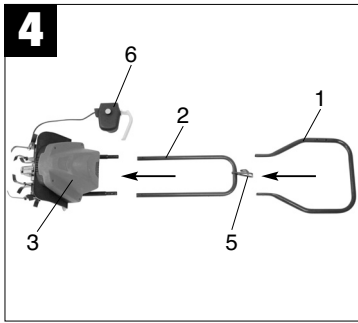

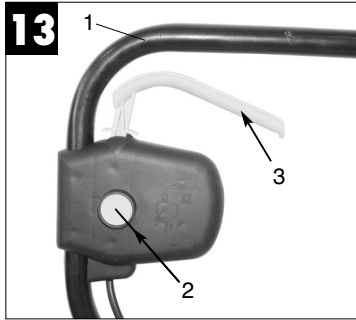
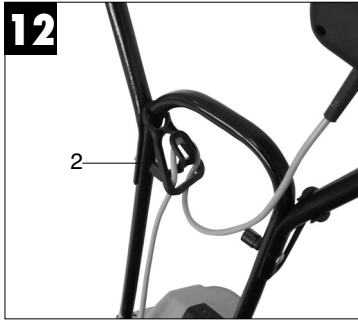
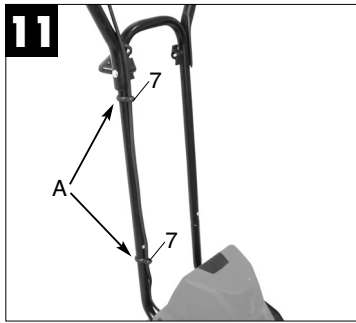
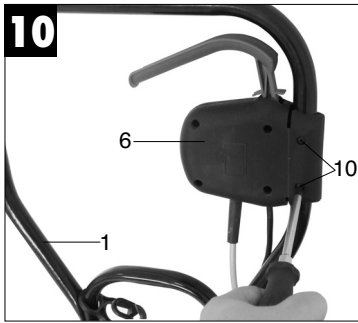



Table of contents

	Page
1. General safety regulations	6
2. Layout and items supplied	6
3. Proper use	6
4. Proper operation	6
5. Installation	7
6. Starting up	7
7. Tips for proper working	7
8. Maintenance, care and storage	7
9. Replace the hoe blade	8
10. Ordering replacement parts	8
11. Technical data	8
12. Troubleshooting guide	8

Packaging

The unit is supplied in packaging to prevent its being damaged in transit. This packaging is raw material and can therefore be reused or can be returned to the raw material system.

GB

When using equipment, a few safety precautions must be observed to avoid injuries and damage.

- Read the operating instructions carefully and comply with them. It is important to consult these instructions in order to acquaint yourself with the unit, its proper use and safety regulations.
- Keep this manual in a safe place, so that the information is available at all times.
- If you give the equipment to any other person, hand over these operating instructions as well.

We accept no liability for damage or accidents which arise due to non-observance of these instructions.

1. General safety regulations

The general safety instructions and explanations of the information signs are set out in the enclosed booklet.

2. Layout and items supplied (see Fig. 1-3)

1. Top push bar
2. Bottom push bar
3. Motor unit
4. Hoe blades
5. Cable strain-relief clamp
6. Two-hand safety switch
7. Cable securing clips
8. 2x screw for installing the top push bar
9. 2x screw for installing the bottom push bar
10. 2x screw for installing 2-hand safety switch
11. 2x nut M6
12. 2x wing nut

3. Proper use

The machine is designed for digging soil (for example garden beds). Be sure to observe the restrictions in the safety instructions.

4. Proper operation

Power supply

The machine can be connected to any light socket-outlet (with 230 Volt alternating current). However, the socket outlet must have an earthing contact protected by a 16 A circuit breaker. Additionally, a residual current device (RCD) circuit-breaker with max. 30 mA must be used!

Power cable for the device

Please only use power cables that are not damaged. The total length of the power cable should not exceed 50 meters; going beyond this distance will reduce the power output of the electric motor. The power cable must have a cross-section of 3 x 1,5 mm². The insulating sheath of such machines is frequently damaged. Some of the causes for this are:

- Cracking due to old age of the insulation
- Kinking caused by improper fastening or guidance of the power cable

Even though power cables with damaged insulation sheaths pose a lethal hazard, some people still use them. Do not make this mistake! Cables, plugs and socket couplers must meet the following requirements listed below. Power cables used to connect machines must have a rubber insulation sheath.

The power cables must, at the very minimum, be of type HO5RN-F and 3-stranded. The cable type must be printed somewhere on the power cable. Only purchase power cables that are marked! Plugs and socket couplers for the power cables must be made from rubber and splash-proof. There is a limit to how long power cables can be. Longer power cables require larger conductor cross-sections. Power cables and connecting lines must be regularly checked for damage. Ensure that the lines are de-energized before checking them. Completely unwind the power cable. Also check power cable entry points, plugs and socket couplers for kinks.

The machine is intended for private use i.e. for use in home and gardening environments.

The operating instructions as supplied by the manufacturer must be kept and referred to in order to ensure that the machine is properly used and maintained. The instructions contain valuable information on operating, maintenance and servicing conditions.

For safety reasons, the machine may not be used as a drive unit for other work tools or tool sets of any kind.

5. Assembly (Fig. 4-11)

Place the motor unit and the push bars on the ground in order (Fig. 4). Important. Do not forget to slide the cable strain-relief clamp (Fig. 6/Item 5) over the bottom push bar. Slide the bottom push bar on to the push bar holder and secure the two components to each other (Fig. 5). Now secure the top push bar to the bottom push bar (Fig. 6). Install the 2-hand safety switch as shown in Fig. 7-10. Secure the cable using the supplied cable securing clips (Fig. 11/A)

6. Starting up

Secure the power cable with the strain-relief clamp (Fig. 12/Item 2).

Important! To prevent accidental start-up of the machine, the push-bar (Fig. 13/Item 1) is equipped with a two-point switch (Fig. 13/Item 2) which must be pressed before the lever switch (Fig. 13/Item 3) can be pressed. If the lever switch is released, the machine switches off. Repeat this process several times so that you are sure that your machine functions properly. Before you perform any repair or maintenance work on the machine, ensure that the hoe blades are not rotating and that the power supply is disconnected.

Always ensure that a safe distance (provided by the long handles) is maintained between the machine and the user. Be especially careful when changing direction on slopes and inclines. Maintain a solid footing and wear sturdy, non-slip footwear and long trousers. Always till along the incline (not up and down).

Use special caution when backing up and pulling the machine (tripping hazard).

7. Tips for proper working

Place the machine in front of the area you wish to hoe and hold it securely on the push bar before you switch on the machine. Guide the hoe blades over the area.

To achieve cleanly tilled soil always ensure that you guide the machine in straight lines wherever possible. Inso doing, the aeration swaths should always overlap each other by a few centimeters in order to avoid bare strips.

Switch off the motor promptly when you arrive at the end of the area you wished to till. The motor must be switched off when you raise the machine (for example to change direction).

Keep the underside of the machine clean and remove soil deposits. Deposits make it more difficult to start the machine and decrease the working depth. Work perpendicular to the slop on inclined areas. The machine must be switched off and the mains cable disconnected before you make any checks on the hoe blades.

Important!

The tiller blades will continue to rotate for a few seconds after the motor is switched off. Never attempt to manually stop them. In the event that the rotating tiller blade strikes an object, immediately switch off the machine and wait for the tiller blades to come to a complete stop. Then inspect the condition of the tiller blades. Replace any parts that are damaged.

Lay the power cable on the ground in front of the outlet in a figure 8. Work away from the outlet or cable and ensure that the power cable always trails in the tilled soil which will prevent the tiller blades from traveling over the cable.

8. Maintenance, care and storage

Maintenance and cleaning work on the machine as well as removal of the safety devices may only be performed when the motor is switched off and the power cable has been pulled. Worn out or damaged hoe blades should only be replaced by an authorized professional (see address on warranty certificate).

Do not clean the tool with running water - and particularly not with a pressure hose.

Ensure that all mounting components (i.e. screws, bolts, nuts etc.) are always tightened so that the machine can be safely operated at all times.

Store the device in a dry room. All the metal parts should be cleaned and then oil to ensure that they provide a long life. For best results, clean the plastic parts of the machine with a brush or rag. Do not use any solvents to remove dirt.

GB

At the end of the season, perform a general inspection of the machine and remove any deposits which may have accumulated. At the start of each season, ensure that you check the condition of the machine. If repairs are necessary, please contact one of our customer service centers (see address on warranty certificate).

9. Replace the tiller blades

For safety reasons, we recommend having the tiller blades replaced by an authorized professional (see address on warranty certificate).

Important!

Wear working gloves. Use only genuine spare parts since otherwise the function and safety of the machine cannot be guaranteed.

10. Ordering replacement parts

Please quote the following data when ordering replacement parts:

- Type of machine
- Article number of the machine
- Identification number of the machine
- Replacement part number of the part required

Helpline numbers:

UK 0151 649 1500
IRE 189 094 6244

11. Technical data

Voltage	230V ~ 50Hz
Power input	750 W
Working width	30 cm
Tiller diameter	22 cm
Idle speed	400 rpm
Number of blades	4 pieces
L _{pA} noise level	70 dB(A)
L _{WA} peak noise level	93 dB(A)
Vibration at the handlebars a _{HV}	≤ 2.5 m/s ²



12. Troubleshooting guide

Fault	Possible causes	Remedy
Motor does not start	a) No power at the plug b) Cable defective c) Switch/plug block defective d) Motor terminals or capacitor disconnected e) excessive working depth	a) Check the power cable and fuse b) Check c) By customer service workshop d) By customer service workshop e) Reduce working depth
Motor performance drops	a) Soil too hard b) Blades badly worn	a) Correct working depth b) Replace hoe blades

Important note!

For protection, the motor is equipped with a thermal switch which cuts out when the motor is overloaded and switches on again automatically after a short cooling period.

ISC GmbH · Eschenstraße 6 · D-94405 Landau/lsar



Konformitätserklärung

- Ⓔ erklårt folgende Konformität gemäß EU-Richtlinie und Normen für Artikel
- Ⓕ explains the following conformity according to EU directives and norms for the following product
- Ⓖ déclare la conformité suivante selon la directive CE et les normes concernant l'article
- Ⓖ dichiara la seguente conformità secondo la direttiva UE e le norme per l'articolo
- Ⓕ verklaart de volgende overeenstemming conform EU richtlijn en normen voor het product
- Ⓖ declara la siguiente conformidad a tenor de la directiva y normas de la UE para el artículo
- Ⓖ declara a seguinte conformidade, de acordo com a directiva CE e normas para o artigo
- Ⓕ attesterer følgende overensstemmelse i medfør af EU-direktiv samt standarder for artiklet
- Ⓖ förklarar följande överensstämmelse enl. EU-direktiv och standarder för artikeln
- Ⓕ vakuuttaa, että tuote täyttää EU-direktiivin ja standardien vaatimukset
- Ⓖ tõendab toote vastavust EL direktiivile ja standarditele
- Ⓕ vydává následující prohlášení o shodě podle směrnice EU a norem pro výrobek
- Ⓕ potvrjuje sledeću skladnost s smernico EU in standardi za izdelek
- Ⓕ vydáva nasledujúce prehlásenie o zhode podľa smernice EÚ a noriem pre výrobok
- Ⓕ a cikkekhöz az EU-irányvonal és Normák szerint a következő konformitást jelemti ki
- Ⓕ deklaruje zgodność wymienionego ponizej artykułu z następującymi normami na podstawie dyrektywy WE.
- Ⓕ декларира съответното съответствие съгласно Директива на ЕС и норми за артикула
- Ⓕ raskaidro šādu atbilstību ES direktīvai un standartiem
- Ⓕ apibūdina šī attikuma EU reikalavimus ir prekės normoms
- Ⓕ deklarā urmātoarea conformitate conform directivei UE și normelor pentru articolul
- Ⓕ δηλώνει την ακόλουθη συμμόρφωση σύμφωνα με την Οδηγία ΕΚ και τα πρότυπα για το προϊόν
- Ⓕ potvrđuje sljedeću usklađenost prema smjernicama EU i normama za artikl
- Ⓕ potvrđuje sljedeću usklađenost prema smjernicama EU i normama za artikl
- Ⓕ potvrđuje sledeću usklađenost prema smernicama EZ i normama za artikla
- Ⓕ следующим удостоверяется, что следующие продукты соответствуют директивам и нормам ЕС
- Ⓕ проголошує про зазначену нижче відповідність виробу директивам та стандартам ЄС на виріб
- Ⓕ ja izjavuwa slednata soobraznost soglasno EU-direktivata i normite za artikli
- Ⓕ Ūrūnū ile ilgili AB direktīfieri ve normlan gereģince aģagida aģiklanan uģunluģu belirtir
- Ⓕ erklærer følgende samsvar i henhold til EU-direktiv og standarder for artikkel
- Ⓕ Lýsir uppfyllingu EU-reglna og annarra staðla vöru

Electric Tiller EBH 750 (Einhell Royal)

- 87/404/EC_2009/105/EC
- 2005/32/EC_2009/125/EC
- 2006/95/EC
- 2006/28/EC
- 2004/108/EC
- 2004/22/EC
- 1999/5/EC
- 97/23/EC
- 90/396/EC_2009/142/EC
- 89/686/EC_96/58/EC
- 2006/42/EC
- Annex IV
Notified Body No.:
Reg. No.:
- 2000/14/EC_2005/88/EC
- Annex V
- Annex VI
Noise: measured L_{WA} = 91 dB (A); guaranteed L_{WA} = 93 dB (A)
P = 0,75 kW; L/G = 22 cm
Notified Body: TÜV Rheinland LGA Products GmbH (0197)
- 2004/26/EC
Emission No.:

Standard references: EN 60335-1; EN 709; EN 55014-1; EN 55014-2; EN 61000-3-2; EN 61000-3-3

Landau/lsar, den 18.10.2010

[Signature]
Weichselgartner/General Manager

[Signature]
Gao/Product-Manager/IT

First CE: 07
Art.-No.: 34.310.13 I.-No.: 11020
Subject to change without notice

Archive-File/Record: 3431015-05-4155050-09
Documents registrar: Scheiff Alexander
Wiesenweg 22, D-94405 Landau/lsar



Ⓢ For EU countries only

Never place any electric tools in your household refuse.

To comply with European Directive 2002/96/EC concerning old electric and electronic equipment and its implementation in national laws, old electric tools have to be separated from other waste and disposed of in an environment-friendly fashion, e.g. by taking to a recycling depot.

Recycling alternative to the demand to return electrical devices:

As an alternative to returning the electrical device, the owner is obliged to cooperate in ensuring that the device is properly recycled if ownership is relinquished. This can also be done by handing over the used device to a returns center, which will dispose of it in accordance with national commercial and industrial waste management legislation. This does not apply to the accessories and auxiliary equipment without any electrical components which are included with the used device.

Ⓢ The reprinting or reproduction by any other means, in whole or in part, of documentation and papers accompanying products is permitted only with the express consent of ISC GmbH.

Ⓢ Technical changes subject to change

GUARANTEE CERTIFICATE

Dear Customer,

In the unlikely event that your device develops a fault, we are truly sorry for this, and suggest that you please contact our service department at the address shown on this guarantee card, or contact the nearest authorised DIY store. Please note the following terms, under which guarantee claims can be made:

1. These guarantee terms cover additional guarantee rights and do not affect your statutory warranty rights. We do not charge you for this guarantee.
2. Our guarantee only covers problems caused by material or manufacturing defects, and it is restricted to the rectification of these defects or replacement of the device. Please note that our devices have not been designed for use in commercial, trade or industrial applications. Consequently, the guarantee is invalidated if the equipment is used in commercial, trade or industrial applications or for other equivalent activities. The following are also excluded from our guarantee: compensation for transport damage, damage caused by failure to comply with the installation/assembly instructions or damage caused by unprofessional installation, failure to comply with the operating instructions (e.g. connection to the wrong mains voltage or current type), misuse or inappropriate use (such as overloading of the device or use of non-approved tools or accessories), failure to comply with the maintenance and safety regulations, ingress of foreign bodies into the device (e.g. sand, stones or dust), effects of force or external influences (e.g. damage caused by the device being dropped) and normal wear resulting from proper operation of the device. This applies in particular to rechargeable batteries for which we nevertheless issue a guarantee period of 12 months.

The guarantee is rendered null and void if any attempt is made to tamper with the device.
3. The guarantee is valid for a period of 2 years starting from the purchase date of the device. Guarantee claims should be submitted before the end of the guarantee period within two weeks of the defect being noticed. No guarantee claims will be accepted after the end of the guarantee period. The original guarantee period remains applicable to the device even if repairs are carried out or parts are replaced. In such cases, the work performed or parts fitted will not result in an extension of the guarantee period, and no new guarantee will become active for the work performed or parts fitted. This also applies when an on-site service is used.
4. In order to assert your guarantee claim, please send your defective device postage-free to the address shown below, or contact the nearest authorised DIY store. Please enclose either the original or a copy of your sales receipt or another dated proof of purchase. Please keep your sales receipt in a safe place, as it is your proof of purchase. It would help us if you could describe the nature of the problem in as much detail as possible. If the defect is covered by our guarantee then your device will either be repaired immediately and returned to you, or we will send you a new device.

Of course, we are also happy offer a chargeable repair service for any defects which are not covered by the scope of this guarantee or for units which are no longer covered. To take advantage of this service, please send the device to our service address.