

REPLACEMENT WARRANTY
12 MONTHS HOME USE

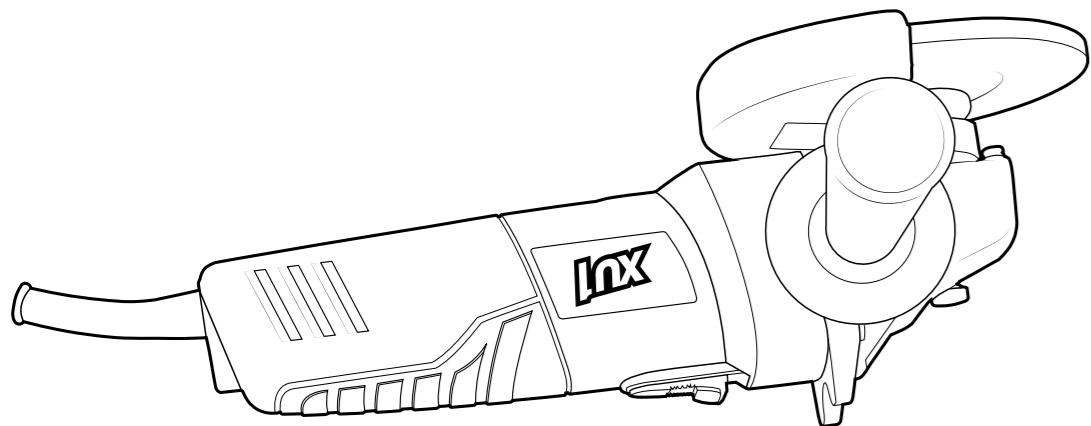

500W
Angle
Grinder

IXX

XU1 Power tools

iSC GmbH, Eschenstraße 6, D-94405 Landau, Germany

Telephone: GB: 0151 294 4488 / IRL: 1850 882711

SAFETY INSTRUCTIONS

ALWAYS WEAR EYE, FACE AND EAR PROTECTION

Description of symbols

- Read instruction manual
- Do not expose to rain
- Wear dust mask
- Wear ear protection
- Wear eye protection
- Double insulated
- V** Volts
- ~** Alternating current
- /min** Revolutions, reciprocations or strokes per minute
- no** No load speed
- Hz** Hertz
- W** Watts
- Warning

General Power Tool Safety Warnings

WARNING! Read all safety warnings and all instructions. Failure to follow the warnings and instructions may result in electric shock, fire and/or serious injury. Save all warnings and instructions for future reference. The term "power tool" in all of the warnings refers to your mains-operated (corded) power tool or battery-operated (cordless) power tool.

1) Work area safety

a) Keep work area clean and well lit. Cluttered and dark areas invite accidents.

b) Do not operate power tools in explosive atmospheres, such as in the presence of flammable liquids, gases or dust.

Power tools create sparks which may ignite the dust or fumes.

c) Keep children and bystanders away while operating a power tool. Distractions can cause you to lose control.

2) Electrical safety

a) Power tool plugs must match the outlet. Never modify the plug in any way. Do not use any adapter plugs with earthed (grounded) power tools. Unmodified plugs and matching outlets will reduce risk of electric shock.

b) Avoid body contact with earthed or grounded surfaces such as pipes, radiators, ranges and refrigerators. There is an increased risk of electric shock if your body is earthed or grounded.

c) Do not expose power tools to rain or wet conditions. Water entering a power tool will increase the risk of electric shock.

d) Do not abuse the cord. Never use the cord for carrying, pulling or unplugging the power tool. Keep cord away from heat, oil, sharp edges or moving parts. Damaged or entangled cords increase the risk of electric shock.

e) When operating a power tool outdoors, use an extension cord suitable for outdoor use. Use of a cord suitable for outdoor use reduces the risk of electric shock.

f) If operating a power tool in a damp location is unavoidable, use a residual current device (RCD) protected supply. Use of an RCD reduces the risk of electric shock.

3) Personal safety

a) Stay alert, watch what you are doing and use common sense when operating a power tool. Do not use a power tool while drugs, alcohol or medication. A moment of inattention while operating power tools may result in serious personal injury.

b) Use personal protective equipment. Always wear eye protection. Personal protective equipment such as dust mask, non-skid safety shoes, hard hat, or hearing protection used for appropriate conditions will reduce personal injuries.

c) Prevent unintentional starting. Ensure the switch is in the off-position before connecting to power source and/or battery pack, picking up or carrying the tool. Carrying power tools with your finger on the switch or energising power tools that have the switch on invites accidents.

d) Remove any adjusting key or wrench before turning the power tool on. A wrench or a key left attached to a rotating part of the power tool may result in personal injury.

e) Do not overreach. Keep proper footing and balance at all times. This enables better control of the power tool in unexpected situations.

f) Dress properly. Do not wear loose clothing or jewellery. Keep your hair, clothing and gloves away from moving parts. Loose clothes, jewellery or long hair can be caught in moving parts.

g) If devices are provided for the connection of dust extraction and collection facilities, ensure these are connected and properly used. Use of dust collection can reduce dust-related hazards.

4) Power tool use and care

a) Do not force the power tool. Use the correct power tool for your application. The correct power tool will do the job better and safer at the rate for which it was designed.

b) Do not use the power tool if the switch does not turn it on and off. Any power tool that cannot be controlled with the switch is dangerous and must be repaired.

c) Disconnect the plug from the power source and/or the battery pack from the power tool before making any adjustments, changing accessories, or storing power tools. Such preventive safety measures reduce the risk of starting the power tool accidentally.

d) Store idle power tools out of the reach of children and do not allow persons unfamiliar with the power tool or these instructions to operate the power tool. Power tools are dangerous in the hands of untrained users.

e) Maintain power tools. Check for misalignment or binding of moving parts, breakage of parts and any other condition that may affect the power tools operation. If damaged, have the power tool repaired before use. Many accidents are caused by poorly maintained power tools.

f) Keep cutting tools sharp and clean. Properly maintained cutting tools with sharp cutting edges are less likely to bind and are easier to control.

g) Use the power tool, accessories and tool bits etc. in accordance with these instructions and in the manner intended for the particular type of power tool, taking into account the working conditions and the work to be performed.

Use of the power tool for operations different from those intended could result in a hazardous situation.

5) Service

a) Have your power tool serviced by a qualified repair person using only identical replacement parts. This will ensure that the safety of the power tool is maintained.

WARNING! a) This power tool is intended to function as a grinder, sanding or cut-off tool. Read all safety warnings, instructions, illustrations and specifications provided with this power tool.

Failure to follow all instructions listed below may result in electric shock, fire and/or serious injury.

b) Operations such as wire brushing, or polishing are not recommended to be performed with this power tool. Operations for which the power tool was not designed may create a hazard and cause personal injury.

c) Do not use accessories which are not specifically designed and recommended by the tool manufacturer. Just because the accessory can be attached to your power tool, it does not assure safe operation.

d) The rated speed of the accessory must be at least equal to the maximum speed marked on the power tool. Accessories running faster than their rated speed can break and fly apart

e) The outside diameter and the thickness of your accessory must be within the capacity rating of your power tool. Incorrectly sized accessories cannot be adequately guarded or controlled.

f) The arbour size of wheels, flanges, backing pads or any other accessory must properly fit the spindle of the power tool. Accessories with arbour holes that do not match the mounting hardware of the power tool will run out of balance, vibrate excessively and may cause loss of control.

g) Do not use a damaged accessory. Before each use inspect the accessory such as abrasive wheels for chips and cracks, backing pad for cracks, tear or excess wear, wire brush for loose or cracked wires. If power tool or accessory is dropped, inspect for damage or install an undamaged accessory. After inspecting and installing an accessory, position yourself and bystanders away from the plane of the rotating accessory and run the power tool at maximum no-load speed for one minute. Damaged accessories will normally break apart during this test time.

h) Wear personal protective equipment. Depending on application, use face shield, safety goggles or safety glasses. As appropriate, wear dust mask, hearing protectors, gloves and workshop apron capable of stopping small abrasive or work piece fragments. The eye protection must be capable of stopping flying debris generated by various operations. The dust mask or respirator must be capable of filtering particles generated by your operation. Prolonged exposure to high intensity noise may cause hearing loss.

i) Keep bystanders a safe distance away from work area. Anyone entering the work area must wear personal protective equipment. Fragments of workpiece or of a broken accessory may fly away and cause injury beyond immediate area of operation.

j) Hold power tool by insulated gripping surfaces only, when performing an operation where the cutting accessory may contact hidden wiring or its own cord. Cutting accessory contacting a "live" wire may make exposed metal parts of the power tool "live" and shock the operator.

k) Position the cord clear of the spinning accessory. If you lose control, the cord may be cut or snagged and your hand or arm may be pulled into the spinning accessory.

l) Never lay the power tool down until the accessory has come to a complete stop. The spinning accessory may grab the surface and pull the power tool out of your control.

m) Do not run the power tool while carrying it at your side. Accidental contact with the spinning accessory could snag your clothing, pulling the accessory into your body.

n) Regularly clean the power tool's air vents. The motor's fan will draw the dust inside the housing and excessive accumulation of powdered metal may cause electrical hazards.

o) Do not operate the power tool near flammable materials. Sparks could ignite these materials.

p) Do not use accessories that require liquid coolants. Using water or other liquid coolants may result in electrocution or shock.

Kickback and related warnings

Kickback is a sudden reaction to a pinched or snagged rotating wheel, backing pad, brush or any other accessory. Pinching or snagging causes rapid stalling of the rotating accessory which in turn causes the uncontrolled power tool to be forced in the direction opposite of the accessory's rotation at the point of the binding.

For example, if an abrasive wheel is snagged or pinched by the work piece, the edge of the wheel that is entering into the pinch point can dig into the surface of the material causing the wheel to climb out or kick out. The wheel may either jump toward or away from the operator, depending on direction of the wheel's movement at the point of pinching. Abrasive wheels may also break under these conditions. Kickback is the result of power tool misuse and/or incorrect operating procedures or conditions and can be avoided by taking proper precautions as given below.

a) Maintain a firm grip on the power tool and position your body and arm to allow you to resist kickback forces. Always use auxiliary handle, if provided, for maximum control over kickback or torque reaction during start-up. The operator can control torque reactions or kickback forces, if proper precautions are taken.

b) Never place your hand near the rotating accessory. Accessory may kickback over your hand.

c) Do not position your body in the area where power tool will move if kickback occurs. Kickback will propel the tool in direction opposite to the wheel's movement at the point of snagging.

d) Use special care when working corners, sharp edges etc. Avoid bouncing and snagging the accessory. Corners, sharp edges or bouncing have a tendency to snag the rotating accessory and cause loss of control or kickback.

e) Do not attach a saw chain woodcarving blade or toothed saw blade. Such blades create frequent kickback and loss of control.

Additional safety instructions for grinding and abrasive cutting-off operations

a) Use only wheel types that are recommended for your power tool and the specific guard designed for the selected wheel. Wheels for which the power tool was not designed cannot be adequately guarded and are unsafe.

b) The guard must be securely attached to the power tool and positioned for maximum safety, so the least amount of wheel is exposed towards the operator. The guard helps to protect operator from broken wheel fragments and accidental contact with wheel.

c) Wheels must be used only for recommended applications. For example: do not grind with the side of cut-off wheel. Abrasive cut-off wheels are intended for peripheral grinding, side forces applied to these wheels may cause them to shatter.

d) Always use undamaged wheel flanges that are of correct size and shape for your selected wheel. Proper wheel flanges support the wheel thus reducing the possibility of wheel breakage. Flanges for cut-off wheels may be different from grinding wheel flanges.

e) Do not use worn down wheels from larger power tools. Wheel intended for larger power tool is not suitable for the higher speed of a smaller tool and may burst.

Additional safety instructions for abrasive cutting-off operations:

a) Do not "jam" the cut-off wheel or apply excessive pressure. Do not attempt to make an excessive depth of cut. Overstressing the wheel increases the loading and susceptibility to twisting or binding of the wheel in the cut and the possibility of kickback or wheel breakage.

b) Do not position your body in line with and behind the rotating wheel. When the wheel, at the point of operation, is moving away from your body, the possible kickback may propel the spinning wheel and the power tool directly at you.

c) When wheel is binding or when interrupting a cut for any reason, switch off the power tool and hold the power tool motionless until the wheel comes to a complete stop. Never attempt to remove the cut-off wheel from the cut while the wheel is in motion otherwise kickback may occur. Investigate and take corrective action to eliminate the cause of wheel binding.

d) Do not restart the cutting operation in the work piece. Let the wheel reach full speed and carefully reenter the cut. The wheel may bind, walk up or kickback if the power tool is restarted in the work piece.

e) Support panels or any oversized work piece to minimize the risk of wheel pinching and kickback. Large work pieces tend to sag under their own weight. Supports must be placed under the work piece near the line of cut and near the edge of the work piece on both sides of the wheel.

f) Use extra caution when making a "pocket cut" into existing walls or other blind areas. The protruding wheel may cut gas or water pipes, electrical wiring or objects that can cause kickback.

Additional safety instructions for sanding operations

a) Do not use excessively oversized sanding disc paper. Follow manufacturers recommendations, when selecting sanding paper. Larger sanding paper extending beyond the sanding pad presents a laceration hazard and may cause snagging, tearing of the disc or kickback.

The tool is recommended for use with a residual current device with a rated residual current of 30mA or less.

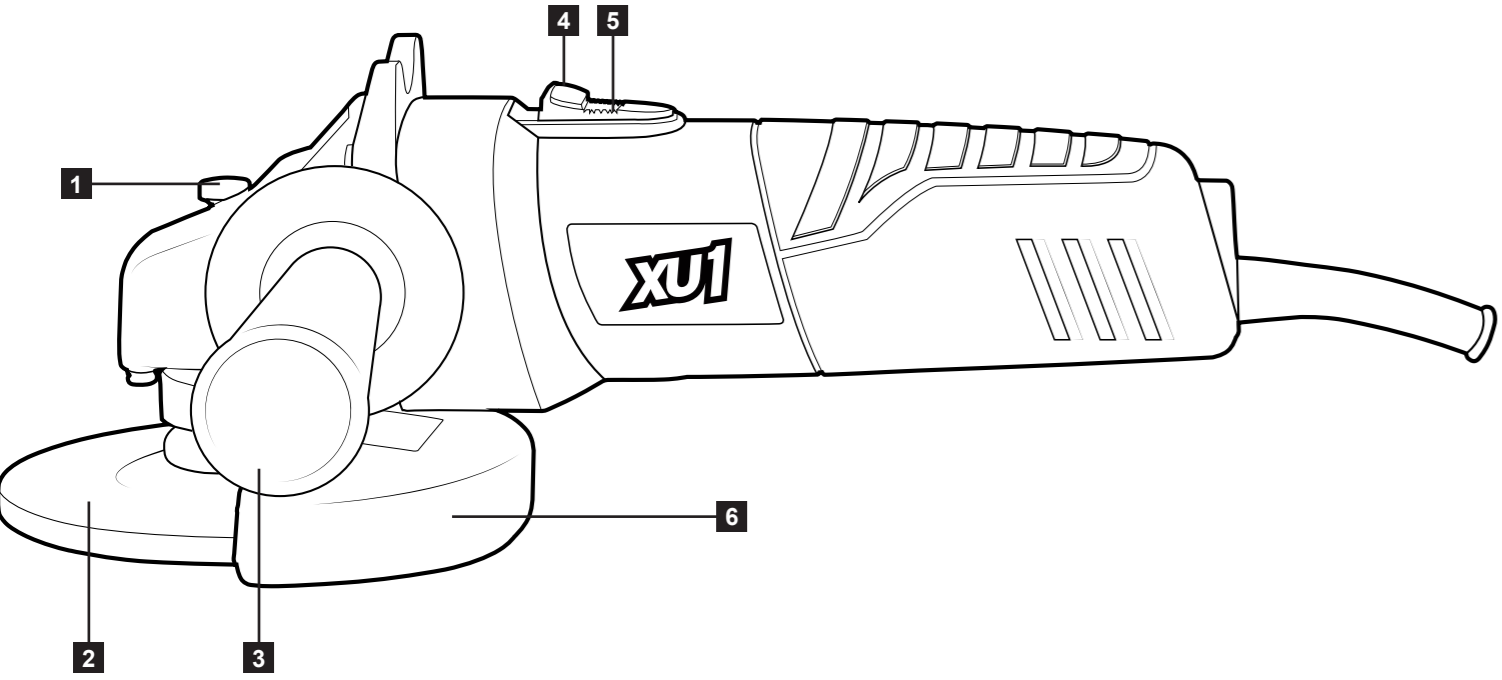

- 1 Spindle Lock Button
- 2 Grinding Disc
- 3 Side Handle
- 4 Lock-Off Button
- 5 On/Off Switch
- 6 Grinding Guard

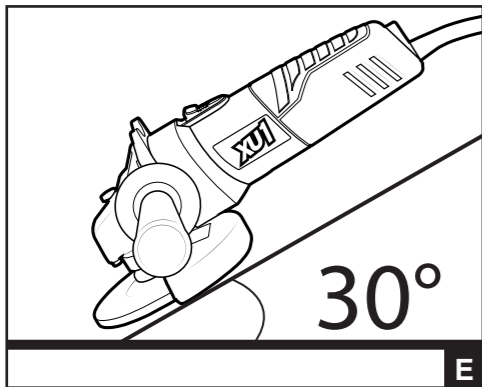
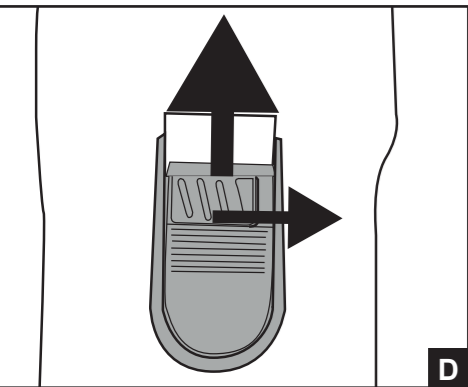
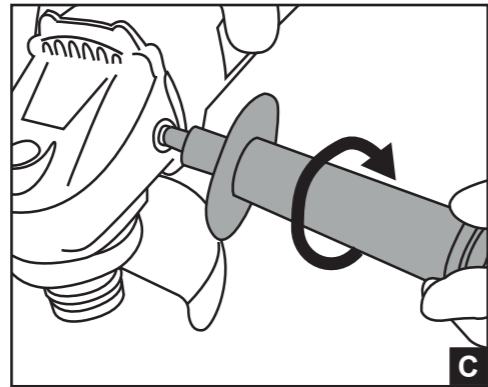
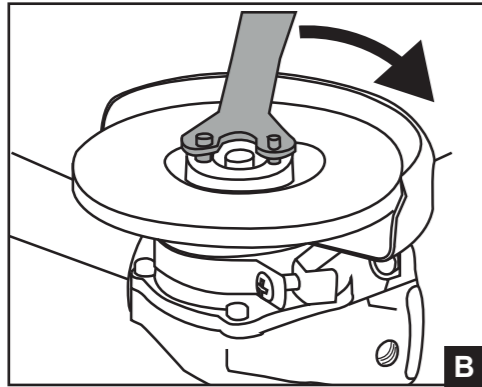
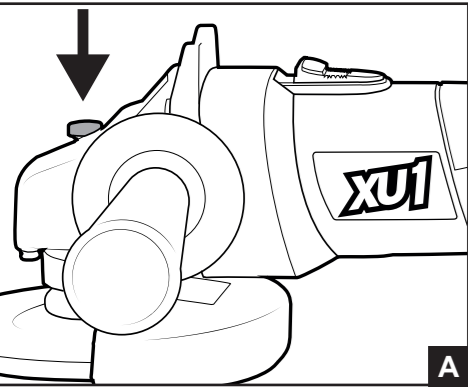

SPECIFICATIONS

Input Voltage:	230V~ 50Hz
Input Power:	500W
Disc Diameter:	115mm (4.5")
No Load Speed:	12,000/min
Spindle Thread:	M14
Weight:	1.5kg

USING YOUR ANGLE GRINDER

WARNING! Before use always read the safety instructions given on the rear of this manual. Failure to comply with the precautions stated could lead to a fire, serious injury or death.

WARNING! Be sure to disconnect the Angle Grinder from the power supply before attaching or removing the disc attachment.

CAUTION: We highly recommend that when using abrasive cutting wheels, that a cutting guard should be fitted to your angle grinder. These cutting guards are available as a spare part and can be ordered through the special orders desk.

Make sure the grinding disc is mounted with the label on top or facing the Angle Grinder.

If you are fitting any other kind of attachment, refer to attachment fitment Instructions. XU1 tools will not be responsible for any damage or injury caused due to the incorrect fitment of grinding disc or any other kind of attachment. Incorrect attachments can cause the motor to burn out, generally damage the tool or cause injury.

Your XU1 115mm Angle Grinder has been designed to grind all types of material when used in a DIY (Do It Yourself) context or for hobbyist purposes. It is not built for continuous daily use in a trade or professional capacity. You will need to select the appropriate disc depending on the type of material you are grinding. Please discuss replacement discs with your retailer. When grinding, do not force the Angle Grinder. The weight of the Angle Grinder itself should provide all the force that is required.

If the tool slows significantly, lift it away from the surface to allow it to regain speed. Continuous use at lower speeds will result in permanent damage to your tool.

Attaching and removing the grinding disc provided

1. Inspect the grinding disc before fitting and during use to ensure it is not deformed or cracked.

2. Ensure that the guard is fitted in a position which ensures it is between you and the grinding disc. The guard is there to protect you from flying objects that may be dislodged at the work piece and from accidental contact of your hand, fingers or other part of our body with the disc.

3. Do not fit or use grinding disc for cutting applications. Grinding discs should be used for grinding metal only.

4. The grinding disc provided is not solid. It is made from grit which is bonded together with reinforcement and adhesives. It is always possible that a part of the disc can dislodge and fly away from the tool at high speed. This is why you must wear the appropriate safety equipment (glasses, gloves and protective clothing) and follow all safety instructions detailed in this manual.

5. Do not use any kind of attachment (Discs or otherwise) that has a diameter greater than 115mm

6. Remove the outer flange by hand if loose

7. If the outer flange is tight, depress the spindle lock button at the top of the gear box housing and rotate the spindle until it locks in position. Once the spindle is locked and cannot be rotated, use the pin wrench supplied to loosen the outer flange. **Fig A**

8. Remove the grinding disc from its envelope

9. Hold the Angle Grinder with the spindle facing upwards and make sure that the inner flange is on the spindle and located correctly. The two machined flat sections on one side of the inner flange must face the Angle Grinder and located in the appropriate position on the spindle.

10. Insert the grinding disc onto the Angle Grinder spindle with the disc label facing the Angle Grinder. The hole in the disc should be located onto the spindle. Ensure that the hole in the disc locates and fits firmly into the ring section of the inner flange.

11. Screw the outer flange onto the spindle with the protruding ring section facing the Angle Grinder. This ring section must locate with the hole in the grinding disc.

12. Tighten the outer flange by locking the spindle and tighten with the pin wrench provided. **Fig B**

13. To remove the disc, first lock the spindle and loosen the outer flange with the pin wrench. Thereafter, remove the outer flange and the grinding disc.

14. Regularly check that the outer flange has not loosened during use.

Attaching the side handle

The auxiliary handle should be assembled to the Angle Grinder prior to use.

This is done by screwing the threaded end of the side handle firmly into the handle mounting points on the alloy gear case of the Angle Grinder **Fig C**

The auxiliary handle can be fitted to the left or right side of the Angle Grinder to maximise user comfort according to the type of application being undertake.

Choose the most appropriate position considering user comfort (preferred hand) and the task at hand.

To reduce the risk of injury and to ensure maximum control during use, hold the tool with both hands while the tool is in operation

Operating the on/off switch

1. To turn the Angle Grinder on, slide the lock-off button located on top of the main switch to the right, then push the switch to the on position. **Fig D**

2. To turn the Angle Grinder off, Push the on/off switch back into the off position.

Safe use and operation of the Angle Grinder

- Do not expose the tool to rain or snow. Do not use the tool in damp locations or in an environment with explosive or corrosive gas.
- Keep your work area well lit.
- Make sure you are well balanced when using the tool and you have secure footing. Do not use the tool when you are tired.
- Keep long hair away from the Angle Grinder.
- Always inspect the Angle Grinder before use – have any damage repaired by an authorised XU1 Tools service agent.
- Make sure the disc is not contacting the work piece when the switch is turned on.
- Keep the guard in place.
- Adjust the position of the guard to best shield the user from sparks according to the application.
- Use only discs having a maximum operating speed at least as high as "No Load Speed" marked on the nameplate.
- Check the disc carefully for cracks or damage before operation. Replace cracked or damaged discs immediately.
- Be careful not to damage the spindle or either of the disc flanges. Damage to these parts could result in disc breakage.
- Hold the tool firmly.
- Before using the tool on an actual work piece, let it run for a while. Watch for vibration or wobbling that could indicate poor installation of the disc or a poorly balanced disc.
- Use only disc designed for each specified function and purpose. Do not use cutting discs for grinding or metal wheels on masonry.
- Hold the tool at an angle of approximately 15°-30° to the work piece surface. **Fig E**

16. To prevent a new grinding disc from digging in to the work piece, initial grinding should be conducted by drawing the Angle Grinder towards yourself. Once the leading edge of the disc is worn a little, it's possible to grind in any direction.

17. It should never be necessary to force the tool. If the rotational speed drops abnormally, pressure should be released immediately. Little more than the weight of the tool should be applied. Forcing and excessive pressure can cause dangerous disc breakage or damage to the tool.

MAINTENANCE

WARNING! Ensure the tool is turned off and disconnected from the power supply before performing any of the following operations.

1. When not in use the Angle Grinder should be stored in a dry, frost free location not within reach of children.

2. Keep ventilation slots of the Angle Grinder clean at all times and prevent any foreign matter from entering them. 3. If the enclosure of the Angle Grinder requires cleaning do not use solvents but a moist soft cloth only.

4. The grease in the gearbox will require replacement/ replenishment after extensive use of the Angle Grinder. Please see your authorised service agent to provide this service.

5. Regularly check the carbon brushes. Brushes should be replaced before they wear out. Both brushes should be replaced at the same time.

6. If the supply cord of this power tool is damaged, it must be replaced by a specially prepared cord available through the service organization. should be replaced before they wear out. Both brushes should be replaced at the same time.

NOTE: XU1 Tools will not be responsible for any damage or injuries caused by repair of the Angle Grinder by an unauthorised person or by mishandling of the tool.

WARRANTY

All of our products undergo strict quality checks to ensure that they reach you in perfect condition. In the unlikely event that your device develops a fault, please contact our service department at the address shown on this guarantee card. You can also contact us by telephone using the customer service number shown. Please note the following terms under which guarantee claims can be made:

1. These warranty terms regulate additional warranty services, which the manufacturer mentioned below promises to buyers of its new products in addition to their statutory guarantee claims are not affected by this guarantee. Our guarantee is free of charge to you.

2. The warranty services only covers defects due to material or manufacturing faults on a product which you have bought from the manufacturer mentioned below are limited to either the rectification of said defects on the product or the replacement of the product, whichever we prefer. Please note that our devices are not designed for use in commercial, trade or professional applications. A guarantee contract will not be created if the device has been used by commercial, trade or industrial business or has been exposed to similar stresses during the guarantee period.

3. The following are not covered by our guarantee:

- Damage to the device caused by a failure to follow the assembly instructions or due to incorrect installation, a failure to follow the operating instructions (for example connecting it to an incorrect mains voltage or current type) or a failure to follow the maintenance and safety instructions or by exposing the device to abnormal environmental conditions or by lack of care and maintenance.
- Damage to the device caused by abuse or incorrect use (for example overloading the device or the use or unapproved tools or accessories), ingress of foreign bodies into the device (such as sand, stones or dust, transport damage), the use of force or damage caused by external forces (for example by dropping it).
- Damage to the device or parts of the device caused by normal or natural wear or tear or by normal use of the device.

4. Your Product is guaranteed for a period of 12 months from the original date of purchase and is intended for DIY (Do It Yourself) use only. Warranty excludes consumable parts. Guarantee claims should be submitted before the end of the guarantee period within two weeks of the defect being noticed. No guarantee claims will be accepted after the end of the guarantee period. The original guarantee period remains applicable to the device even if repairs are carried out or parts are replaced. In such cases, the work performed or parts fitted will not result in an extension of the guarantee period, and no new guarantee will become active for the work performed or parts fitted. This also applies if an on-site service is used.

IN ORDER TO MAKE A CLAIM UNDER THIS WARRANTY YOU MUST RETURN THE PRODUCT TO THE PLACE OF PURCHASE WITH YOUR REGISTER RECEIPT.

Please refer to the restrictions of this warranty concerning wearing parts, consumables and missing parts as set out in the service information in these operating instructions.

CUSTOMER SERVICE HELPLINE
GB: 0151 294 4488
IRL: 1850 882711

XU1
Unit 9 Stadium Court, Wirral International Business Park, Plantation Road, Bromborough, Wirral, CH62 3QG