



ZKG 305 L Sliding Mitre Saw

Art.-No. 43.007.01

The ZKG 305 L sliding mitre saw for easy, precise and smooth cutting of wood parts. The saw even allows double mitre cuts thanks to its tilting and swivelling motor head. For increased cutting precision, the saw has been equipped with a laser function, i.e. a laser beam is projected onto the section plane of the workpiece. The stable supplied base frame allows working at optimum working heights. Thanks to its sliding function, the saw can make cuts up to 310 mm wide and is therefore ideal for cutting wide panels and laminate floorboard in one go.

Features

- Carbide-tipped saw blade with 24 teeth (1)
- Highgrade rotating table made of aluminium for precise angle cuts ranging from -52° to $+45^{\circ}$ (2)
- Including laser (3)
- Slide supported by pipe-in-pipe system (4)
- Motor head continuously tiltable to the left from 0° to $+45^{\circ}$
- Clamping device for fixating of workpiece
- Practical saw blade storage on the backside
- Including dust box and castor with end stop
- Spindle-lock for an easier change of the saw blade
- Softstart

Technical Data

- Mains: 230 V ~ 50 Hz
- Power: 1,800 W
- No-load speed: $4,800 \text{ min}^{-1}$
- Carbide tipped saw blade: $\varnothing 210 \times \varnothing 30 \times 2.8 \text{ mm}$
- No. of teeth: 24
- Turning range: -52° to $+60^{\circ}$
- Panels up to max.: 310 mm
- Mitre cut: 0° to 45° to the left
- Cutting width at max. 90° : $310 \times 65 \text{ mm}$
- Cutting width at max. 45° : $220 \times 65 \text{ mm}$
- Cutting width at max. $2 \times 45^{\circ}$: $220 \times 35 \text{ mm}$
(Double mitre cut)
- Net weight: 23.1 kg
- Gross weight: 27.7 kg
- Packing dimensions: $780 \times 490 \times 400 \text{ mm}$
- Bar code: 4006825 555042
- Sales unit: 1 pc

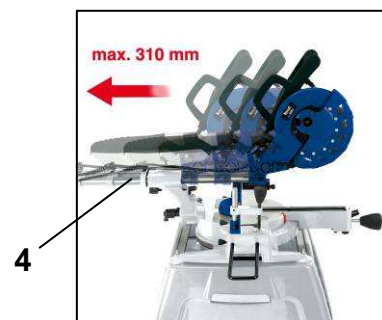
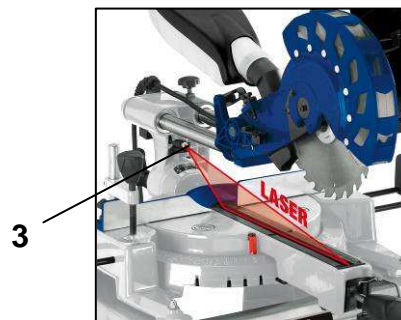

As special accessories available:

TCT saw blade

$\varnothing 210 \times \varnothing 30$, 48 teeth

Art.-No.: 45.020.34

Bar code: 4006825 456110

TCT saw blade

$\varnothing 210 \times \varnothing 30$, 24 teeth

Art.-No.: 45.020.48

Bar code: 4006825 456004