



## 3HP 50L AIR COMPRESSOR USER GUIDE

Now you have purchased a Workzone® product you can rest assured in the knowledge that as well as your 3 year parts and labour warranty you have the added peace of mind of dedicated helplines and web support.

### AFTER SALES SUPPORT

☎ 0044 151 649 1500  
☎ 0044 1890 946 244 📄 [www.einhell.co.uk](http://www.einhell.co.uk)

MODEL: WAC 3050/1 91977 03/2015

### Product Info



[www.aldi.co.uk](http://www.aldi.co.uk)

**+ VIDEO**

## **Congratulations!**

**You have made an excellent choice with the purchase of this quality Workzone® product.**

**By doing so you now have the assurance and peace of mind which comes from purchasing a product that has been manufactured to the highest standards of performance and safety, supported by the high quality standards of ALDI.**

**We want you to be completely satisfied with your purchase so this Workzone® product is backed by a comprehensive manufacturer's 3 year warranty and an outstanding after sales service through our dedicated Helpline.**

**We hope you will enjoy using your purchase for many years to come.**

**If you require technical support or in the unlikely event that your purchase is faulty please telephone our Helpline for immediate assistance. Faulty product claims made within the 3 year warranty period will be repaired or replaced free of charge provided that you have satisfactory proof of purchase (keep your till receipt safe!). This does not affect your statutory rights. However, be aware that the warranty will become null and void if the product is found to have been deliberately damaged, misused or disassembled.**



# Contents

---

- 04** Safety information
- 09** Parts description and assembly
- 15** Instructions
- 20** Frequently asked questions
- 21** Technical data
- 22** Warranty Certificate



# Safety information

# 1



Read these operating instructions carefully before you use the product. Familiarise yourself with how it works and how it is operated. Make sure that the product is serviced as instructed so that it always works efficiently. The operating instructions and the associated documentation must be kept near to the product. Make sure that the operating instructions are included if you pass the product on to another user.

## Scope of use

The compressor is designed to generate compressed air for compressed air driven tools. The equipment is allowed to be used only for its intended purpose. Any other use is deemed to be a case of misuse. The user/operator and not the manufacturer will be liable for any damage or injuries of any kind resulting from such misuse. Please note that our equipment has not been designed for use in commercial, trade or industrial applications.

## Key to symbols

The following symbols are used in these instructions and/or on the machine.



Complies with basic applicable safety standards in European directives



Refers to risk of injury, danger to life and limb and possible damage to the machine if these operation instructions are not followed



Indicates hazard as a result of electric current



Pull plug from socket



Caution! The compressor starts up without warning





Hazard as a result of high temperatures. Caution! The compressor contains parts that can heat up excessively



Wear ear protectors



Guaranteed sound power level LWA



The device must not be disposed of with the household rubbish. Electrical and electronic devices that are damaged and/or due for disposal must be taken to designated recycling sites

## Safety information

**Caution! The following basic safety actions must be taken when using this compressor in order to protect the user from electric shocks and the risk of injury and fire. Read and follow these instructions before using the device.**

This equipment is not designed to be used by people (including children) with limited physical, sensory or mental capacities or those with no experience and/or knowledge unless they are supervised by a person who is responsible for their safety or they have received instructions from such a person in to how to use the equipment safely.

Children must always be supervised in order to ensure that they do not play with the equipment.

1. **Keep your work area tidy.** Untidy work areas can result in accidents.
2. **Make allowance for ambient conditions.** Do not expose the compressor to rain. Never use the compressor in damp or wet locations. Provide good lighting. Do not use the compressor near flammable liquids or gases.
3. **Guard against electric shock.** Avoid bodily contact with earthed parts (e.g. pipes, radiators, cookers and refrigerators).
4. **Keep away from children!** Do not allow other persons to touch the compressor or cable, keep them away from your work area.
5. **Keep your compressor in a safe place.** When not in use, the compressor should be stored in a dry, locked room out of the reach of children.



6. **Do not overload your compressor.** It will work better and safer when used within its quoted capacity range.
7. **Wear suitable work clothes.** Never wear loose-fitting clothes or jewellery. They may get caught in moving parts. Rubberized gloves and non-slip shoes are recommended when working outdoors. Wear a hair net if you have long hair.
8. **Do not use the cable for purposes other than that for which it is designed.** Do not carry the compressor by its cable and do not use the cable to pull the plug out of the socket. Protect the cable from heat, oil and sharp edges.
9. **Take care of your compressor.** Keep your compressor clean to ensure that it works efficiently and safely. Follow the maintenance instructions. Check the power plug and cable on a regular basis and have them replaced by an authorized specialist if they are damaged. Check the extension cable regularly and replace it if damaged.
10. **Pull out the power plug.** When the equipment is not in use and before carrying out any maintenance work.
11. **Avoid unintentional starting.** Make sure that the On/Off switch is in the Off position when connecting to the power supply.
12. **Extension cable outdoors.** Use an extension cable outdoors only if it is approved for outdoor duty and is marked accordingly.
13. **Be alert at all times.** Keep an eye on your work. Use common sense when working. Never use the compressor when you are distracted.
14. **Check the compressor for damage.** Before using the compressor again, check the safety devices or any slightly damaged parts to ensure that they are in good working order. Check that the moving parts are working correctly, that they do not jam, and that no parts are damaged. Make sure that all parts are fitted correctly to ensure that the equipment remains safe to use. Unless otherwise stated in the operating instructions, damaged guards and parts have to be repaired or replaced by a customer service workshop. Damaged switches have to be replaced by a customer service workshop. Never use any device with a switch that cannot be turned on and off.
15. **Caution!** For your own safety you must only use the accessories and additional units listed in the operating instructions or recommended or specified by the manufacturer. The use of mounted tools or accessories other than those recommended in the operating instructions or catalogue may place your personal safety at risk.



16. **Repairs may only be carried out by a qualified electrician.** Repair work must only be carried out by a trained electrician, otherwise the equipment may cause accidents.
17. **Noise.** Wear ear muffs when you use the compressor.
18. **Replacing the power cable.** To prevent injury, damaged power cables may only be replaced by the manufacturer or a qualified electrician.

## Special safety rules

- Make sure that the ambient temperature in an enclosed work area is no higher than +25° C in order to ensure that the machine works properly when fully charged with air for a prolonged period of time.
- No connections may be unscrewed when the tank is under pressure. Always make sure that the tank is empty.
- Do not make holes or rivet joints in the tank or deform the compressed air tank.
- Always pull the plug from the socket prior to transport and before carrying out any maintenance or cleaning work on the compressor.
- Do not spray the compressor with water or inflammable liquids.
- No inflammable objects must be situated near the compressor.
- Please do not store or use the compressor and accessories in an environment in which there may be a risk of explosion.
- When the compressor is switched off, turn the pressure switch to "0" (OFF).
- Never direct the air stream at persons or animals.
- Do not transport the compressor when the tank is under pressure.
- Caution: Some compressor parts, such as the head and the leads, can reach high temperatures. To avoid burns, do not touch these parts.
- Always use the handles to transport the device.
- Keep children and animals well away from the area in which the device is used.
- If you use the compressor with end devices for painting:
  - a) Do not work in enclosed areas or near naked flames.
  - b) Make sure that the work area is adequately ventilated.
  - c) Cover your nose and mouth with a suitable mask.
- Do not use the compressor if the power cable or plug is damaged. Have the damaged part replaced with an original part at an authorized service centre.



- If the compressor is set up on an elevated surface, it must be securely fastened to ensure that it cannot fall down during operation.
- To avoid injury and prevent damage to the compressor, do not put objects or hands through the safety grille.
- To avoid serious damage and personal injury, do not direct the compressor and accessories towards people, things or animals.
- Always pull the plug out of the socket when the compressor is not in use.
- Make sure that pneumatic lines are always used for compressed air and that they are suitable for the maximum operating pressure of the compressor.
- Do not attempt to repair damaged lines.

## Mains connection

- The motor is equipped with an overload switch (15). If the compressor overloads, the overload switch will switch off the equipment automatically to protect the compressor from overheating. If the overload switch triggers, switch off the compressor using the On/Off switch (3) and wait until the compressor cools down. Then press the overload switch (15) and restart the compressor.
- Long supply cables, extensions, cable reels etc. cause a drop in voltage and can impede motor start-up.
- At low temperatures below +5° C, sluggishness may make starting difficult or impossible.





# Parts description and assembly

# 2

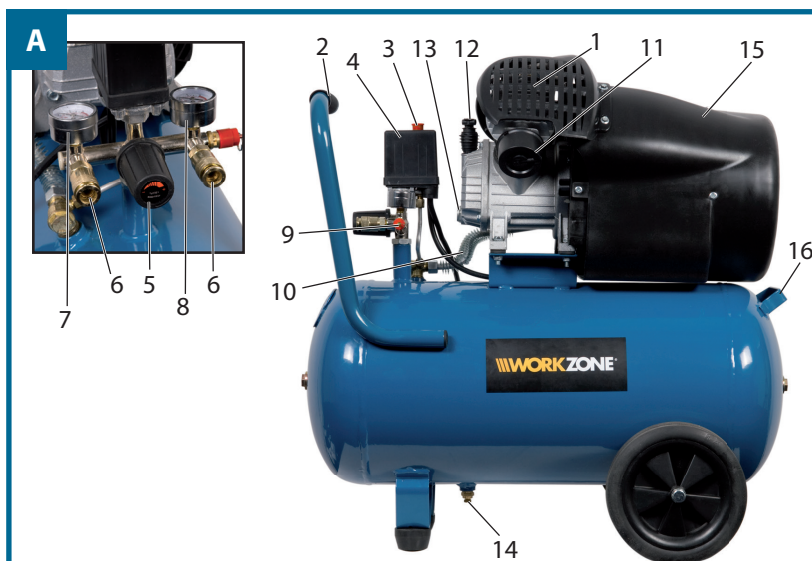

## Parts description

### Fig. A

1. Cover
2. Handle
3. On/Off switch (emergency switch)
4. Pressure switch
5. Pressure regulator
6. Quick-release coupling (outlet)
7. Pressure gauge (pressure regulator)
8. Pressure gauge (tank)
9. Safety valve
10. Discharge line
11. Air filter
12. Oil sealing plug
13. Oil drainage screw (window)

14. Drainage cock
15. Overload switch
16. Transport handle

## Package contents

- 1 Compressor
- 2 Wheels with fastening material (2 wheel bolts, 4 washers, 2 spring washers, 2 nuts)
- 2 Rubber stopper with fastening material (2 screws, 4 washers, 2 nuts)
- 1 Oil sealing plug
- 2 Air filter
- 1 Original operating instructions
- 1 Warranty card

9

AFTER SALES SUPPORT



GB 0044 151 649 1500  
IRE 0044 1890 946 244



[www.einhell.co.uk](http://www.einhell.co.uk)

WAC 3050/1  
03/2015

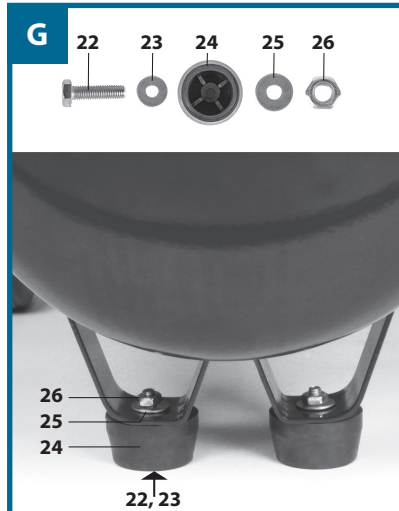
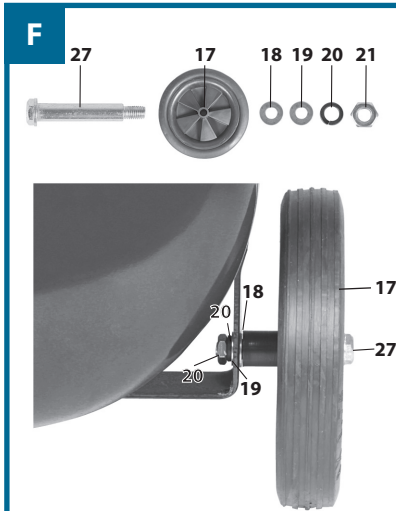
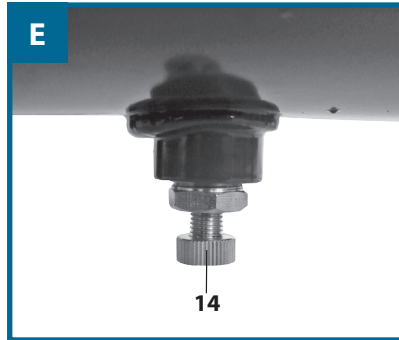
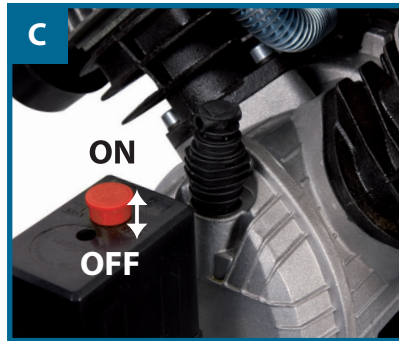

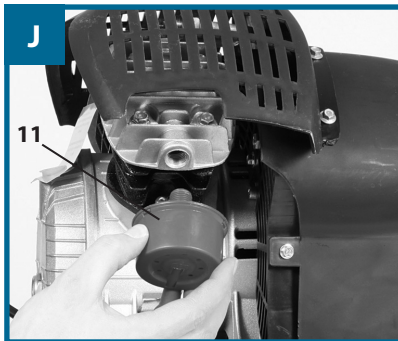
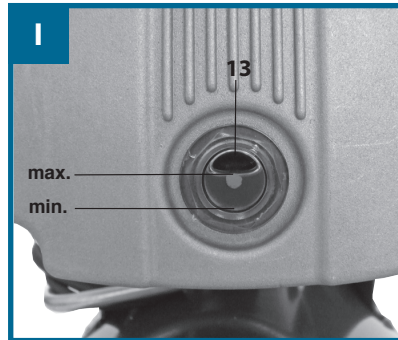
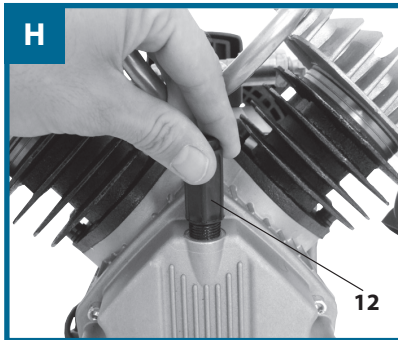

## Spare parts list

No.	Designation	Position
401043001001	Oil filler plug	17
401043001002	Air filter	37
401043001003	Drain cock	67
401043001004	Safety valve	73
401043001005	Universal quick-release coupling	74
401043001006	Pressure gauge	75
401043001007	Automatic pressure switch	76

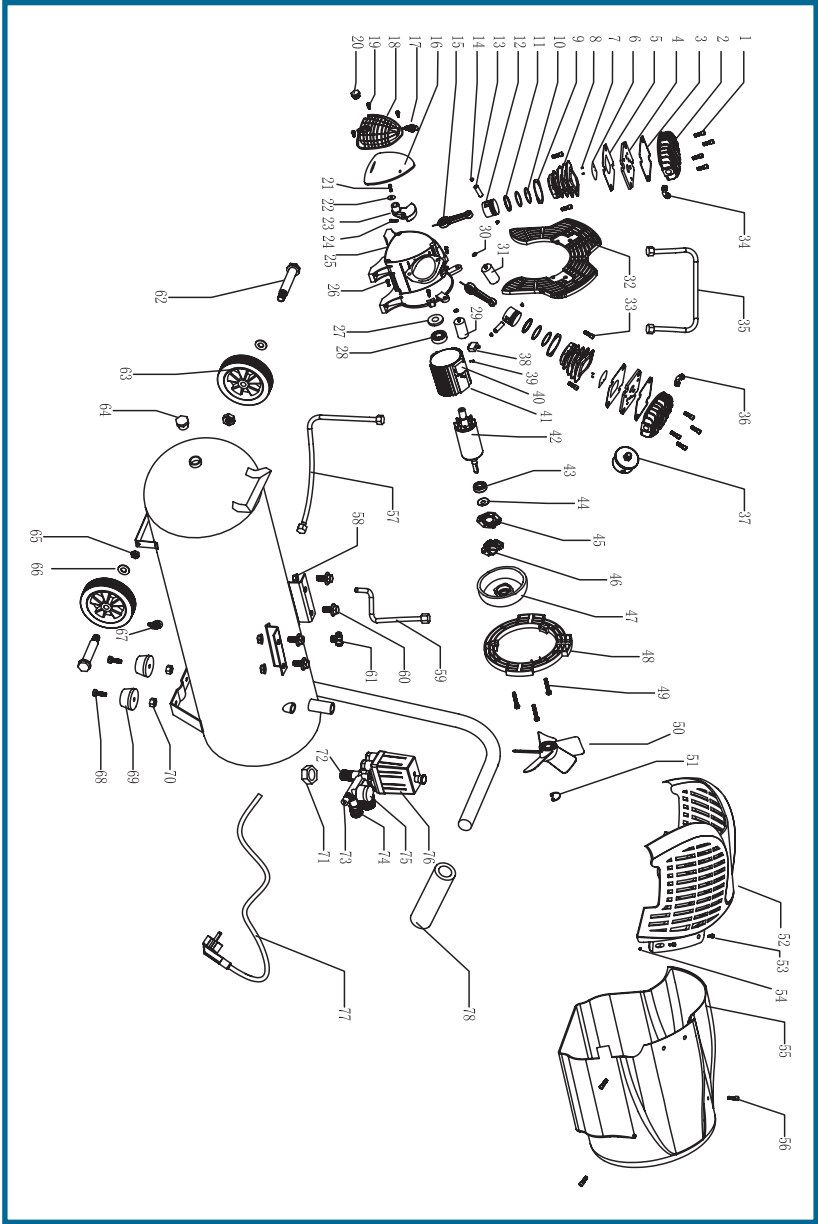



For domestic use only

**Note:** The information in these instructions will help the operator to use and maintain the compressor. If necessary, arrange for another person to help.

- Open the packaging and take out the device with care.
- Remove the packaging material and any packaging and/or transportation braces (if present).
- Check to see if all the items are supplied.
- Inspect the equipment and accessories for transport damage.
- If possible, keep the packaging until the end of the guarantee period.

## Important

The equipment and packaging material are not toys. Do not let children play with plastic bags, plastic sheets and small parts. There is a risk of choking and suffocating!

## Assembly

Once the compressor has been unpacked and checked to ensure that it is in perfect condition and has not been damaged in transit, the following steps must be taken. An open-end wrench or ring wrench (14 mm and 17 mm) is required for assembly.

If not already done:

## Fitting the wheels

Fit the supplied wheels as shown in Fig. F.

## Fitting the supporting feet

Fit the supplied feet as shown in Fig. G.

## Replacing the oil sealing plug

Remove the transportation cover from the oil filler opening with a screwdriver and insert the supplied oil sealing plug (12) into the oil filler opening (Fig. H).



## Fitting the air filter

Remove the transportation cover with a screwdriver or similar and screw the air filter (11) securely to the device (Fig. J).

Assemble the equipment completely before you put it into operation for the first time.

## Setting up the compressor

Set up the compressor in an adequately ventilated place away from atmospheric influences on a level surface or one that is inclined by no more than 10° (Fig. B). Do not set it up in areas where there is a risk of explosion. If the surface is inclined and smooth, it must be ensured that the compressor cannot move out of position during operation. If a board or shelf is used as a base, it must be fixed according to instructions to ensure that the device cannot fall down. To ensure adequate ventilation and effective cooling, the distance between compressor and walls must be at least 100 cm.

## Transporting the compressor



Switch off the device and pull the plug before transporting the device.

Lift the compressor by the handle (2) in order to transport it and push or pull it into the required position. If moving the compressor to another location, it is best carried by two people using both handles (2, 16).



Make sure that the compressor is transported in accordance with instructions. Do not turn it over and do not lift it with the help of hooks or ropes.

## Topping up the compressor oil

The crankcase has capacity for 300 ml of oil. To replenish the oil, remove the oil sealing plug (12) from the oil filler opening. The oil level can be read on the window in the bottom of the crankcase. The crankcase must be filled with oil up to the red marker (Fig. I). Then replace the oil sealing plug.



# Instructions

# 3

## Starting up

- Check whether the mains voltage corresponds to the electrical data on the rating plate (Fig. 10); the maximum permitted deviation is 5%.
- Set the On/Off switch (3) on the top half of the device to the "OFF" position (press in) (Fig. C).
- Put the plug into the socket and switch the On/Off switch (3) to "ON" (pull out) to start up the compressor. The compressor is fully automatic. It is controlled by the pressure switch, which stops the compressor if the pressure in the tank reaches the maximum value and restarts it as soon as the pressure falls to the minimum value. Normally the difference in pressure between the maximum and minimum values is approximately 2 bar/29 psi. Example: The compressor stops working as soon as it reaches 8 bar (116 psi) (max. operating pressure) and restarts automatically when the pressure in the tank falls to 6 bar (87 psi).
- After connecting the compressor to the power supply, fill the tank with air at maximum pressure and check that the device is working properly.



The assembly consisting of head/cylinder/air line can reach high temperatures, so take care when working near to these parts and refrain from touching them in order to avoid burn injuries.

Quick connect coupler (Fig. A, 6): This coupler establishes the connection to the regulated output pressure. Push the coupler in to connect the air hose. To disconnect the air hose, pull back the coupler collar and detach the coupling.

Tank pressure gauge (Fig. A, 8): This measuring instrument measures the pressure of the air stored in the tank. It cannot be set by the operator and it does not indicate the line pressure.



Operating pressure gauge (Fig. A, 7): This measuring instrument measures the operating pressure. The operating pressure can be set with the reducing valve.

Safety valve (Fig. A, 9): If the pressure switch on the motor fails to switch off when the motor reaches the preset pressure, the valve automatically springs open in order to prevent overpressure. To open it manually, pull on the ring on the valve in order to relieve the air pressure in the tank.

## Regulating operating pressure

### Fig. D

There is no need to always use the maximum operating pressure as most compressed air tools have low pressure requirements. The correct operating pressure must be set on compressors fitted with a pressure reduction device. The operating pressure can be set with the help of the pressure regulator (5).

- Turn clockwise to increase the pressure.
- Turn anticlockwise to reduce the pressure.

## After use

- Switch off the equipment after use.
- Pull the mains plug out of the socket when the equipment is not being used.
- Allow the equipment to cool down after use.
- If necessary, disconnect and stow away any attachments and accessories.

## Maintenance



Pull out the plug before carrying out maintenance work on the compressor.

This device has been designed for long-term operation with minimal maintenance. Consistently satisfactory operation depends on correct





maintenance and regular cleaning. Before carrying out any work on the compressor, the following steps must be taken:

- The On/Off switch must be in the "OFF" position (pressed in).
- The plug must be disconnected from the power supply.
- The pressure chamber must be depressurized. To do this, carefully open the drainage cock beneath the tank (Fig. E).

## Cleaning



Caution! Do not use water or a high-pressure cleaner to clean the device. There is a risk of electric shock!

Clean the housing regularly with a soft cloth, preferably after every use. Keep the ventilation slits free of dust and dirt. If it is not possible to remove the dirt in this way, use a soft cloth moistened with soapy water. Never use solvents such as petrol, alcohol, ammonia water etc. These solvents can damage the plastic parts.

## Cleaning/replacing air filter

It is recommended to dismantle the intake filter every 50 hours of operation and to clean the filter element by blowing it out with compressed air (Fig. J). If the compressor is operated in a clean environment, the filter element should be replaced at least once a year; this must be done more frequently in a dusty environment.

## Draining condensed water

The compressor produces condensed water, which collects in the tank. Every time the device is used, the condensed water must be drained from the tank by opening the drainage cock (14) beneath the tank and disposed of in an environmentally compatible manner.

### **Important:**

Take care to ensure that the drainage cock is not fully opened. If there is compressed air inside the tank the drainage cock and the condensed water may be discharged at high pressure.



Recommended pressure: max. 1–2 bar.

Since it contains oil, condensed water from the oil-lubricated compressor must not be drained into the sewers or discharged into the environment.

## Changing/replenishing oil

The compressor is supplied with the synthetic oil SAE 10W40. All the oil in the pump system should be replaced after the first 100 hours of operation.

- Use an open-end wrench or ring wrench (24 mm) to undo the oil drain screw (window) on the cover of the crankcase, allow the oil to drain away completely into a drip tray and reattach the seal.
- Pour the oil through the oil filler opening in the crankcase and then reinsert the sealing plug (12), check the oil level in the pump system every week and replenish with oil as and when required.

Use SAE 10W40 synthetic oil when operating at an ambient temperature of  $-5^{\circ}\text{C}$  to  $+35^{\circ}\text{C}$ . The advantage of synthetic oil is that its characteristics never change in summer or in winter.



The waste oil must not be drained into the sewers or discharged into the environment.

Take note of the information in the following table for an oil change.

### Oil type

Multigrade oils SAE 10W40/15W40

### Operating hours

100 or 6 months

## Faults

If a fault develops e.g. a part wears out, please contact the service address stated on the warranty card. These instructions have a detailed overview of the parts that can be ordered.



## Storage

Switch off the equipment, pull the mains plug out of the socket, and ventilate the appliance and all connected pneumatic tools. Switch off the compressor and make sure that it is secured in such a way that it cannot be started up again by any unauthorized person.

Store the compressor only in a dry location which is not accessible to unauthorized persons. Always store upright, never tilted!

## Environment

The machine is supplied in robust packaging in order to prevent transport damage. The packaging largely consists of recyclable materials. Please therefore take the opportunity to recycle the packaging.



The law stipulates that the device must not be disposed of with the usual household rubbish. Electrical and electronic devices that are damaged and/or due for disposal must be taken to designated recycling sites. Take any waste oil to a collection point for waste oil. Contact your waste management company or local authority for more information.

## Warranty

You will find the warranty terms and conditions on the separately enclosed warranty card.



# Frequently asked questions

## Air loss

- May be caused by a badly sealed connection.
- Check all connections by wetting them with soapy water.

## Compressor will not start

If the compressor fails to start easily, then check the following:

- Does the mains voltage match the voltage shown on the rating plate?
- Has an extension cable with the wrong cross-section or length been used?
- Is the work area too cold (below 0° C)?
- Is there oil in the crankcase to provide adequate lubrication (Fig. I)?
- Is the power supply working (plug properly inserted, overload protection not triggered, fuses not defective)?

## Compressor will not stop

The tank safety valve is activated if the compressor does not stop when it reaches maximum pressure. Contact your nearest authorized service centre to have the device repaired.



# Technical data

# 5

Rated voltage	230 V~
Rated frequency	50 Hz
Power consumption	2.2 kW
Idling speed	2850/min
Protection type: compressor	IP20
Protection type: motor	IP23
Tank capacity	50 litres
Theoretical suction rate	412 l/min
Max. operating pressure	8.0 bar
$L_{WA}$ sound power level	96 dB(A)
$L_{pA}$ sound pressure level	74 dB(A)
K uncertainty	2 dB
Weight	42 kg

The acoustic emission data were calculated in accordance with EN ISO 2151:2008.

The noise level may rise by between 1 and 10 dB(A) depending on the area in which the compressor is set up.

- The product meets the requirements of EN 61000-3-11 and is subject to special connection conditions. This means that use of the product at any freely selectable connection point is not allowed.
- Given unfavourable conditions in the power supply the product can cause the voltage to fluctuate temporarily.
- The product is exclusively intended for use at connection points which
  - a) do not exceed a maximum permitted supply impedance  $Z_{sys} = 0.277 \Omega$ , or
  - b) have a continuous current-carrying capacity of the mains of at least 100 A per phase.
- As the user, you are required to ensure, in consultation with your electric power company if necessary, that the connection point at which you wish to operate the product meets one of the two requirements, a) or b), named above.



# Warranty Certificate

# 6

Dear Customer,

03/2015

All of our products undergo strict quality checks to ensure that they reach you in perfect condition. In the unlikely event that your compressor develops a fault, please contact our service department at the address shown on this warranty card. You can also contact us by telephone using the service number shown below. Please note the following terms under which warranty claims can be made:

1. Our warranty covers only problems caused by material or manufacturing defects, and it is restricted to the rectification of these defects or the replacement of the equipment.

It does not cover replacement work for transport damage, damage caused by failure to follow the assembly and operating instructions, damage through misuse or incorrect applications, damage caused by failure to follow the maintenance and safety instructions, damage resulting from the use of force and external effects, or the normal wear and tear which arises during the proper use of the product.

The warranty is rendered null and void if any attempt is made to tamper with the equipment.

2. No warranty claims will be accepted after the end of the warranty period. This also applies if an on-site service is used.

The warranty is valid for a period of three years starting from the purchase date. Keep your sales receipt in a safe place, as it is your proof of purchase.

Your statutory rights are not affected by this warranty. During the warranty period you can report defective equipment by phone or by writing to the service address below. We will arrange as soon as possible for the defective equipment to be picked up from your address at no charge and will then supply you with a new or repaired replacement free of charge. Alternatively, you can return the defective equipment to the address below yourself (carriage forward).

Please prepare the equipment for the pick-up service (pack it in the original box or comparable box). You can make the arrangements for the pick-up yourself at the website below.

Please note that you or someone acting on your behalf must be available throughout the pick-up day. Don't forget to specify a pick-up address.

During non-office hours you can leave your phone number and we will call you back on the next work day.

After the warranty period has elapsed you can still send a defective item to the address below for repair. Repairs undertaken after the warranty period has ended will normally incur a charge.

## Einhell UK Limited

Unit 9, Stadium Court, Wirral International Business Park,  
Plantation Road, Bromborough, Wirral, CH62 3QG

22

AFTER SALES SUPPORT



GB 0044 151 649 1500  
IRE 0044 1890 946 244



[www.einhell.co.uk](http://www.einhell.co.uk)

WAC 3050/1  
03/2015

# WORKZONE®

## 3HP 50L AIR COMPRESSOR

**IMPORTANT! KEEP THIS FORM SAFE:** Only complete and return this form to the address below in the unlikely event of a warranty claim, if you are requested by the manufacturer to return the item for replacement. Then please complete this form and send it together with your receipt (proof of purchase) to the address below.

### Your details:

Name \_\_\_\_\_

Address \_\_\_\_\_

\_\_\_\_\_

\_\_\_\_\_

 \_\_\_\_\_ E-Mail \_\_\_\_\_

Date of purchase\* \_\_\_\_\_

\*We recommend you keep the receipt with this warranty card

Location of purchase \_\_\_\_\_

### Description of malfunction:

\_\_\_\_\_

Return your completed warranty card to:

Einhell UK Limited

Unit 9, Stadium Court,

Wirral International Business Park,

Plantation Road,





Bromborough,

Wirral, CH62 3QG

sales@einhell.co.uk

technical@einhell.co.uk

### AFTER SALES SUPPORT

   0044 151 649 1500  
 0044 1890 946 244 [www.einhell.co.uk](http://www.einhell.co.uk)

MODEL: WAC 3050/1 91977 03/2015



# 3

YEAR WARRANTY

23

AFTER SALES SUPPORT



 0044 151 649 1500  
 0044 1890 946 244



[www.einhell.co.uk](http://www.einhell.co.uk)

WAC 3050/1  
03/2015



## EU Declaration of Conformity

- D** erkl rt folgende Konformit t gem   EU-Richtlinie und Normen f r Artikel
- GB** explains the following conformity according to EU directives and norms for the following product
- F** d clare la conformit  suivante selon la directive CE et les normes concernant l'article
- I** dichiara la seguente conformit  secondo la direttiva UE e le norme per l'articolo
- NL** verklaart de volgende overeenstemming conform EU richtlijn en normen voor het product
- E** declara la siguiente conformidad a tenor de la directiva y normas de la UE para el art culo
- P** declara a seguinte conformidade, de acordo com a directiva CE e normas para o artigo
- DK** attesterer f lgende overensstemmelse i medf r af EU-direktiv samt standarder for artikel
- S** f rklarar f ljande  verensst mmelse enl. EU-direktiv och standarder f r artikeln
- FIN** vakuuttaa, ett  tuote t ytt   EU-direktiivin ja standardien vaatimukset
- EE** t endab toote vastavust EL direktiivile ja standarditele
- CZ** vyd v  n sleduj c  prohl šení o shod  podle sm rnice EU a norem pro v robek
- SLO** potrjuje sledečo skladnost s smernico EU in standardi za izdelek
- SK** vyd v  n sleduj ce prehl senie o zhode podl'a smernice E  a noriem pre v robok
- H** a cikkekhez az EU-ir nyvonal  s Norm k szerint a k vetkez  konformit st jelenti ki
- PL** deklaruje zgodno c wymienionego poniżej artykułu z nast puj cymi normami na podstawie dyrektywy WE.
- BG** deklariра съответното съответствие съгласно Директива на ЕС и норми за артикул
- LV** paskaidro šadu atbilstību ES direktīvai un standartiem
- LT** apibūdina šį atitikimą EU reikalavimams ir prekės normoms
- RO** declar  urm toarea conformitate conform directivei UE  i normelor pentru articolul
- GR** δηλώνει την ακόλουθη συμμόρφωση σύμφωνα με την Οδηγία ΕΚ και τα πρότυπα για το προϊόν
- HR** potvrđuje sljedeću usklađenost prema smjernicama EU i normama za artikl
- BIH** potvrđuje sljedeću usklađenost prema smjernicama EU i normama za artikl
- RS** potvrđuje sledeću usklađenost prema smernicama EZ i normama za artikl
- RUS** следующим удостоверяется, что следующие продукты соответствуют директивам и нормам ЕС
- UKR** проголошує про зазначену нижче відповідність виробу директивам та стандартам ЄС на виріб
- MK** ja izjavuва slednata soobraznost soglasno E -direktivata i normite za artikli
- TR**  r n  ile ilgili AB direktifleri ve normları gereğince a ağıda a ıklanan uygunluęu belirir
- N** erkl rer f lgende samsvar i henhold til EU-direktivet og standarder for artikkel
- IS** L ysir uppfyllingu EU-reglna og annarra stađla v ru

### Compressor WAC 3050/1 (Workzone)

- |   |  |
|---|--|
| <input checked="" type="checkbox"/> 87/404/EC_2009/105/EC | <input checked="" type="checkbox"/> 2006/42/EC   |
| <input type="checkbox"/> 2005/32/EC_2009/125/EC           | <input type="checkbox"/> Annex IV  |
| <input type="checkbox"/> 2006/95/EC                       | Notified Body:   |
| <input type="checkbox"/> 2006/28/EC                       | Notified Body No.:   |
| <input checked="" type="checkbox"/> 2004/108/EC           | Reg. No.:  |
| <input type="checkbox"/> 2004/22/EC                       | <input checked="" type="checkbox"/> 2000/14/EC_2005/88/EC                              |
| <input type="checkbox"/> 1999/5/EC                        | <input type="checkbox"/> Annex V   |
| <input checked="" type="checkbox"/> 97/23/EC              | <input checked="" type="checkbox"/> Annex VI   |
| <input type="checkbox"/> 90/396/EC_2009/142/EC            | Noise: measured $L_{WA} = 94$ dB (A); guaranteed $L_{WA} = 96$ dB (A)                  |
| <input type="checkbox"/> 89/686/EC_96/58/EC               | P = 2.2 KW; L/  = cm   |
| <input checked="" type="checkbox"/> 2011/65/EC            | Notified Body: T V Rheinland LGA Products GmbH, Tillystra e 2, 90431 N rnberg, Germany |
|   | <input type="checkbox"/> 2004/26/EC  |
|   | Emission No.:  |

Standard references: EN 1012-1; EN 60204-1; EN 55014-1; EN 55014-2; EN 61000-3-2; EN 61000-3-11

Landau/Isar, den 19.09.2014

  
Weichselgartner/General-Manager

  
Schunk/Product-Management

First CE: 14  
Art.-No.: 40.104.34 I.-No.: 11014  
Subject to change without notice

Archive-File/Record: NAPR011207  
Documents registrar: Siegfried Roider  
Wiesenweg 22, D-94405 Landau/Isar











EH 09/2014 (01)