

Operating Instructions



 N16188

Dirty Water Pump

What your 1 year warranty means

Great care has gone into the manufacture of this product and it should therefore provide you with years of good service when used properly. In the event of product failure within its intended use over the course of the first year after the date of purchase, we will remedy the problem as quickly as possible once it has been brought to our attention. In the unlikely event of such an occurrence, or if you require any information about the product please contact us via our after sales support services, details of which can be found in this manual and on the product itself.

Table of contents

1. Safety instructions	page 4
2. Layout	page 4
3. Installation	page 4
4. Mains connection	page 5
5. Areas of application	page 5
6. Starting up	page 5
7. Maintenance instructions	page 5
8. Setting the ON/OFF switching point	page 6
9. Technical data	page 6
10. Performance data	page 6
10. Waste disposal	page 6
12. Ordering replacement parts	page 6
13. Troubleshooting	page 7

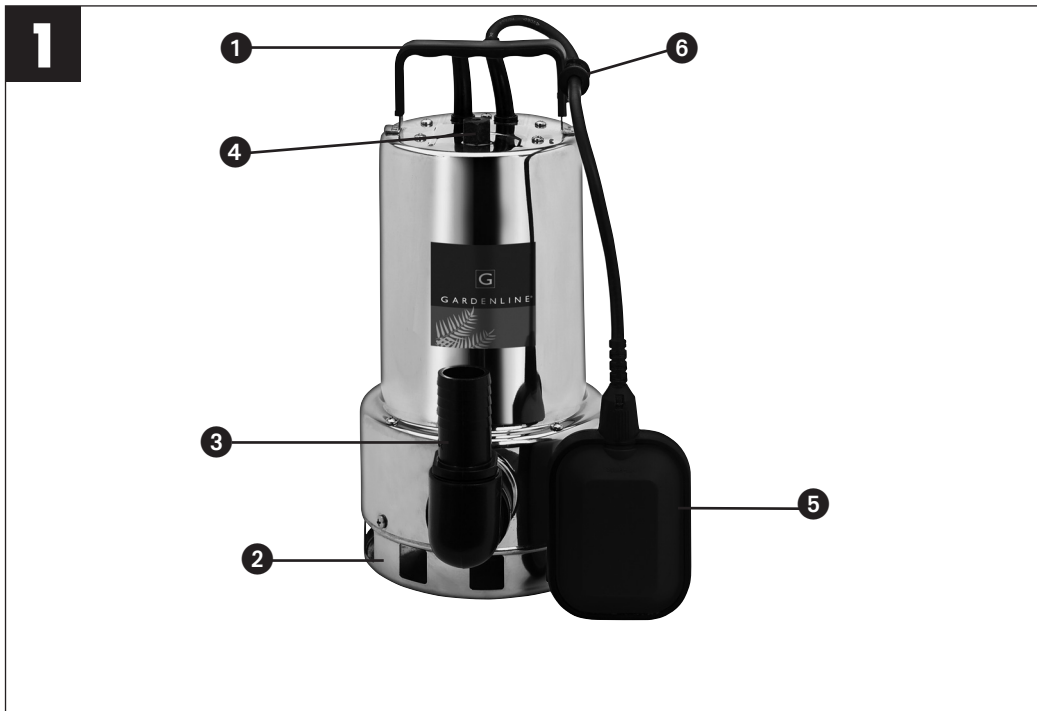

Before you put the dirty water pump into operation, carefully read the following safety regulations and the operating instructions.

If you give the equipment to any other persons, give them the operating instructions as well.

Keep these instructions in a safe place.

Packaging

The unit is supplied in packaging to prevent it from being damaged in transit. The raw materials in this packaging can be reused or recycled.

1. Safety instructions

Caution!

In stagnant water bodies, garden ponds, swimming ponds and their surrounding areas the pump may only be used with an earth-leakage circuit breaker with an actuating rated current of up to 30 mA (acc. to VDE 0100 part 702 and 738). The pump is not designed for use in swimming pools and paddling pools of any kind or other bodies of water in which people or animals may be present during operation.

It is prohibited to operate the pump if a person or animal is in the danger area.

Ask your electrician!

- Before starting to run your new pump, please have the following items checked by an expert:
 - Ground connection
 - Zero conductor
- **Safety circuit breaker switch must correspond to the safety regulations of the power plants and they must work faultlessly.**
- The electrical connections must be protected from moisture.
- If there is danger of flooding, the electrical connections must be taken to higher ground.
- Circulation of aggressive fluids, as well as the circulation of abrasive materials must be avoided at all costs.
- The pump must be protected from frost.
- The pump must be protected from running dry.
- Access on the part of children should also be prevented with appropriate measures.

2. Layout (Fig. 1)

- 1 Handle
- 2 Integrated cable rewind
- 3 Universal hose connection
- 4 Venting
- 5 Floating switch
- 6 Cable holder

3. Installation (Fig. 2)

The pump is installed as follows:

- In a stationary position with fixed pipeline or
- In a stationary position with a flexible hose pipe.

You should never install the pump by suspending it unsupported from its delivery pipe or power cable. The pump must be suspended from the specially provided handle or be placed on the bottom of the shaft. To guarantee that the pump works properly, the bottom of the shaft must be kept free of sludge and dirt of all kinds.

If the water level becomes too low, any sludge in the shaft will dry out quickly and stop the pump from starting up. It is necessary, therefore, to check the submersible motor pump regularly (by carrying out start-up tests).

The float is adjusted in a way that the pump can immediately be started

The pump shaft should have minimum dimensions of 40 x 40 x 50 cm, so that the floating switch can move freely.

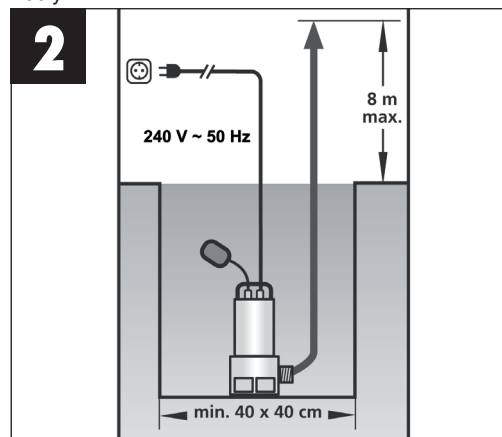

4. Mains supply

Your new pump is equipped with a shock-proof plug according to regulations. The pump is designed to be connected to a 240 V ~ 50 Hz safety socket.

Make sure that the socket is sufficiently secured (min. 6 Amp.) and is in excellent condition. Introduce the plug into the socket and the pump is ready to go.

Important Note!

If the mains cable or plug suffers any damage from external action, repairs to the cable are prohibited.

5. Areas of use

This pump is used primarily as a cellar pump. When installed in a shaft, this pump provides protection from flooding.

They are also used wherever water has to be moved from one place to another, e.g. in the home, agriculture, horticulture, plumbing and many other applications.

This pump is not for commercial use.

Your pump is designated for the circulation of water with a maximum temperature of 35° C.

This pump may not be used for other fluids, especially motor fuels, cleaning fluids, and other chemical products!

6. Setting to work

After having read these instructions carefully, you can set your pump to work, reconsidering the following items:

- Check if the pump rests on the ground of the shaft.
- Check if pressure cord has been attached properly .
- Check if electrical connection is 240 V ~ 50 Hz.
- Check if socket is in good condition.
- Make sure that water and humidity can never come to the mains supply.
- Avoid pump running dry.

7. Maintenance guidelines

This pump is an approved, maintenance-free high quality product, which is subject to severe final controls.

We recommend, regular inspection and maintenance to ensure long equipment life and uninterrupted operation.

Important! Note!

- Remove the mains plug before all maintenance work.
- In the event that the pump is often transported in the course of operation, it should be cleaned out with clear water after every use.
- In case of stationary installation, the function of the floating switch should be checked every 3 months.
- All fibrous particles which may have built-up inside the pump housing should be removed with a water jet.
- Every 3 months the shaft ground and walls should be cleaned from mud.
- Remove deposits on the floater with clear water.

Cleaning the impeller

If excessive deposits collect in the pump case, you must dismantle the bottom part of the pump as follows:

1. Undo the 4 screws from the bottom of the intake cage.
2. Remove the intake cage from the pump case.
3. Clean the impeller with clear water.

Important! Do not put down or rest the pump on the impeller!

4. Assemble in reverse order



8. Setting the ON/OFF switching point (Fig. 4+5)

The ON/OFF switching point can be infinitely adjusted with the height adjustment facility.

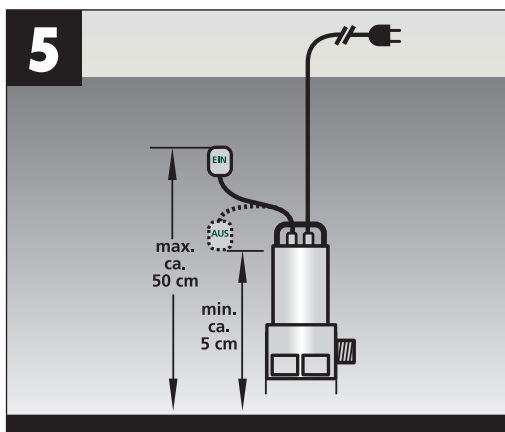

Before you put the pump into operation, please check the following:

- The float switch must be installed so that the level of the ON operating point and the level of the OFF operating point can be reached easily and with little force. To check this, place the pump in a vessel filled with water, raise the float switch carefully by hand and then lower it again. As you do so, note whether the pump switches on and off.
- Make sure that the distance between the float switch head and the latching holder is not too small. Proper operation is not guaranteed if the gap is too small.
- When you set the float switch, make sure that it does not touch the base before the pump switches off. **Caution! Risk of running dry.**

9. Technical Data

Power supply	240V ~ 50Hz
Power consumption	1,000 Watt
Delivery rate max..	20.000 L/h
Delivery height max	8 m
Immersion depth max.	5 m
Water temperature max.	35°C
Hose connection	1 1/2" threaded end
Foreign bodies up to	dia. 20 mm
Switching point height: ON	max. approx. 50 cm
Switching point height: OFF	min. approx. 5 cm

10. Performance data

11. Disposal and recycling

Delivery head	Delivery rate
2 m	max.: 18,200 l/h
4 m	max.: 14,800 l/h
6 m	max.: 10,400 l/h
8 m	max.: 7,170 l/h

The unit and its accessories are made of various types of material, such as metal and plastic. Defective components must be disposed of as special waste. Ask your dealer or your local council.

12. Ordering replacement parts

Please quote the following data when ordering replacement parts:

- Type of machine
- Article number of the machine
- Identification number of the machine
- Replacement part number of the part required

13. Troubleshooting

Problem	Causes	Solutions
Pump does not start	<ul style="list-style-type: none">– No mains supply– Float switch does not activate pump	<ul style="list-style-type: none">– Check mains supply– Adjust float to a higher position
No flow	<ul style="list-style-type: none">– Inlet sieve is clogged– Pressure hose is bent	<ul style="list-style-type: none">– Clean inlet sieve water jet– Reset hose
Pump does not switch off	<ul style="list-style-type: none">– Float cannot sink down	<ul style="list-style-type: none">– Place pump properly on shaft ground
Insufficient flow	<ul style="list-style-type: none">– Inlet sieve is clogged– Reduced pumping capacity by dirty and abrasive water	<ul style="list-style-type: none">– Clean inlet sieve– Clean pump and replace worn-out parts
Pump switches off after short operating period	<ul style="list-style-type: none">– Thermal cutout stops pump due to dirty water– Water too hot. Thermal-cutout stops pump	<ul style="list-style-type: none">– Remove mains plug. Clean pump and shaft– Make sure that a water temperature of max. 35°C is not exceeded

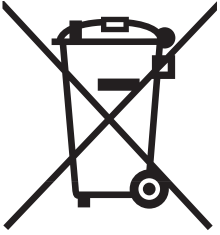

Never place any electric tools in your household refuse.

Seek advice on correct disposal from local waste authorities.



©

The reprinting or reproduction by any other means, in whole or in part, of documentation and papers accompanying products is permitted only with the express consent of ISC GmbH.

© Technical changes subject to change

After Sales Support TEL: 1300 130 579 WEB: www.rossmac.com

EH 06/2008 (01)