



Einhell

BLUE

BT-MS 2112 Mitre Saw

Art.-No. 43.002.90

The mitre saw warrants a clean and smooth cut of wooden parts without problems. Double mitre cut are possible with its tilting and swivelling motor-head.

Features

- Carbide tipped saw blade (1)
- Rotating table (3) for precise angle cuts ranging (2) -45° to +45° turnable
- Position of lock in 0°/ 5°/ 10°/ 15°/ 22,5°/ 30°/ 35°/ 40°/ 45°
- Tilting motor head continuously from 0° to +45° to the left
- Workpiece support (4)
- Clamping device (5)
- Table insert (6) with scale
- Inclusive dust bag (7) and transport locking

Technical Data

- Mains: 230 V ~ 50 Hz
- Power: 1,400 W S1; 1,600 W S6 40%
- Idle speed n_0 : 5,000 min^{-1}
- TCT saw blade / teeth: \varnothing 210 x \varnothing 30 mm / 48 teeth
- Max. saw width 90°/ 45°: 120 x 55 mm / 80 x 55 mm
- Max. saw width 2 x 45°: 80 x 32 mm
- Cutting width until max: 120 mm
- Product weight: 6.4 kg

Logistic Data

- Net weight: 7.1 kg
- Gross weight: 7.9 kg
- Packing dimensions: 475 x 320 x 290 mm
- Bar code: 4006825 572995
- Sales unit: 1 pc

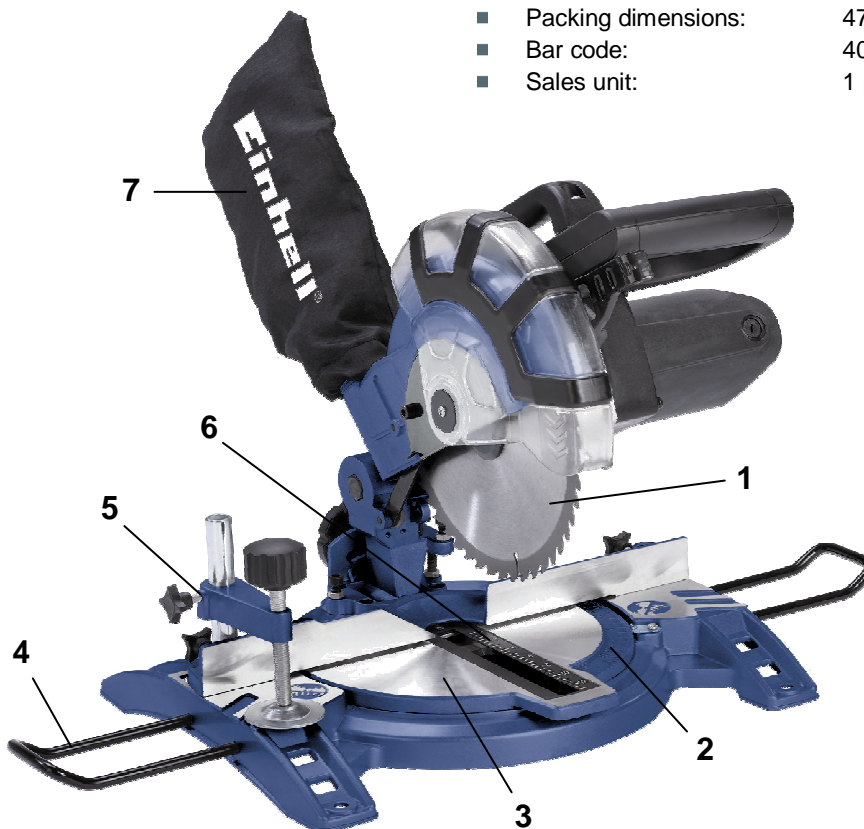

As special accessories available:

HM-Sägeblatt

\varnothing 210 x \varnothing 30 mm 24 Zähne

HM-Sägeblatt

\varnothing 210 x \varnothing 30 mm 48 Zähne

Art.-Nr.: 45.020.48

EAN-Code: 4006825456004

Art.-Nr.: 45.020.34

EAN-Code: 4006825456110

CV-Sägeblatt

\varnothing 210 x \varnothing 30 mm 72 Zähne

HM-Sägeblattset

\varnothing 210 x \varnothing 30 x 2,5 mm

Art.-Nr.: 45.020.42

EAN-Code: 4006825456042

Art.-Nr.: 45.021.32

EAN-Code: 4006825534269