



Einhell®

Original operating instructions
Cordless drill/screwdriver

GB



7

Art.-Nr.: 45.132.67

I.-Nr.: 11010

RT-CD **18/1-2B Li**



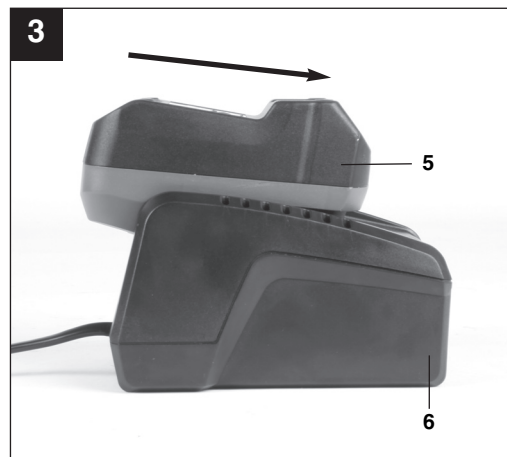
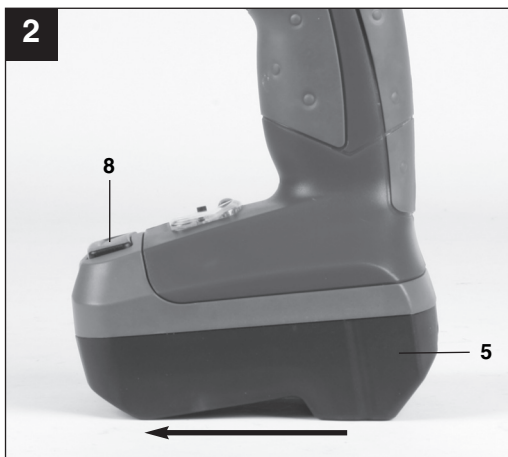
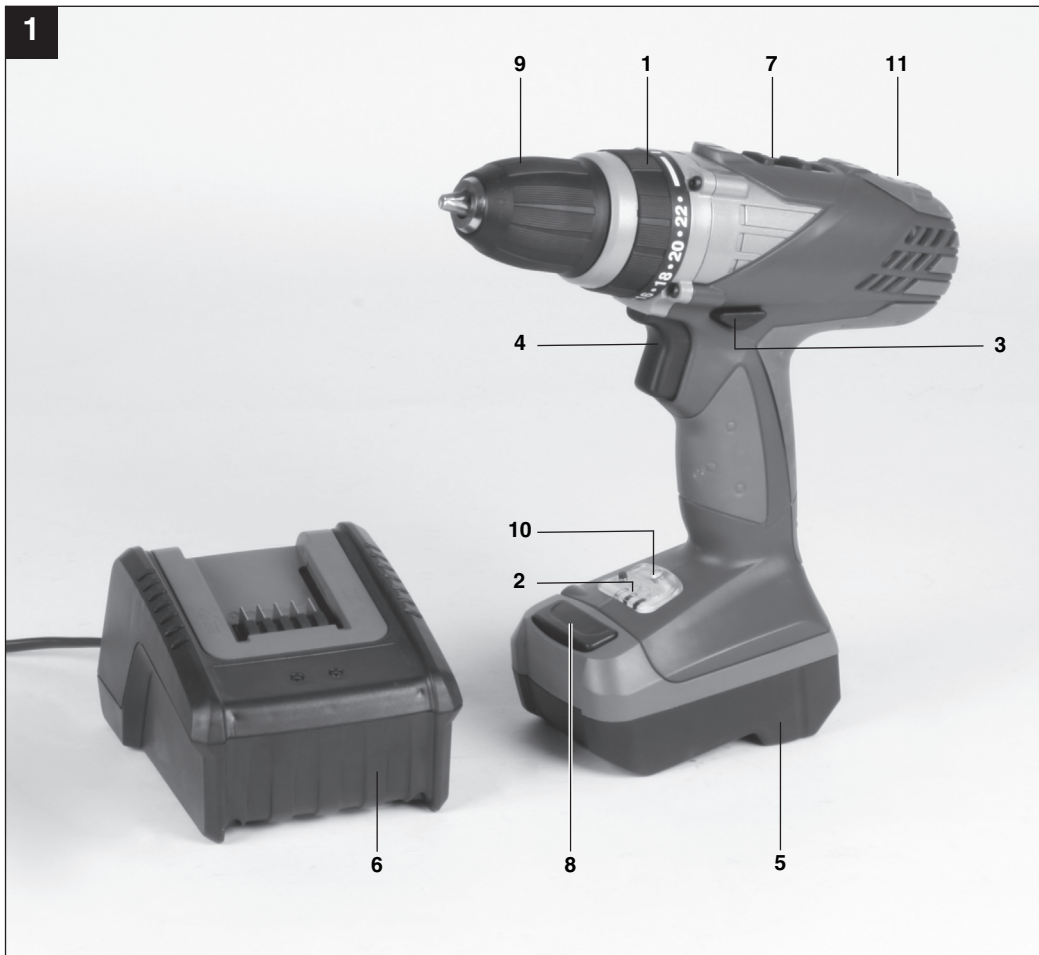

2

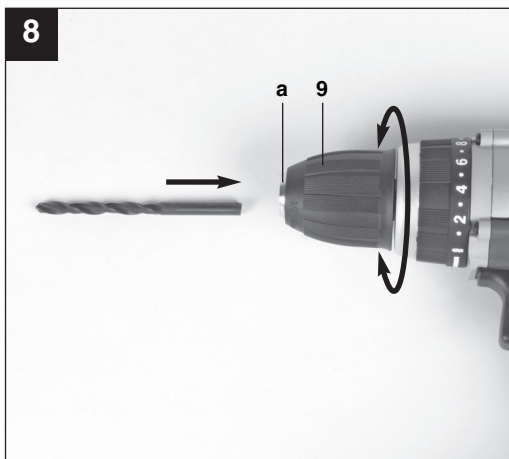
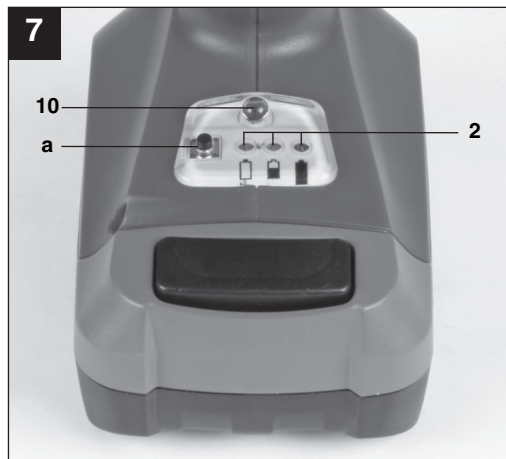
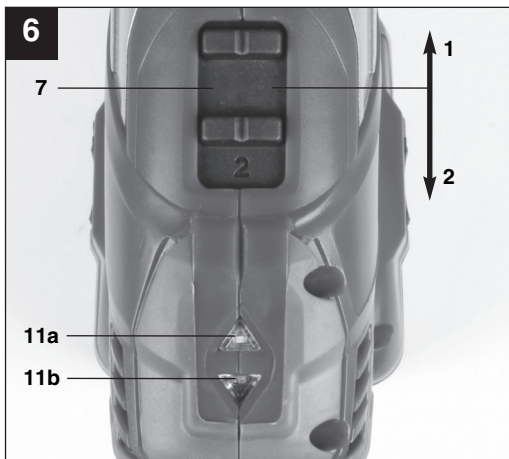
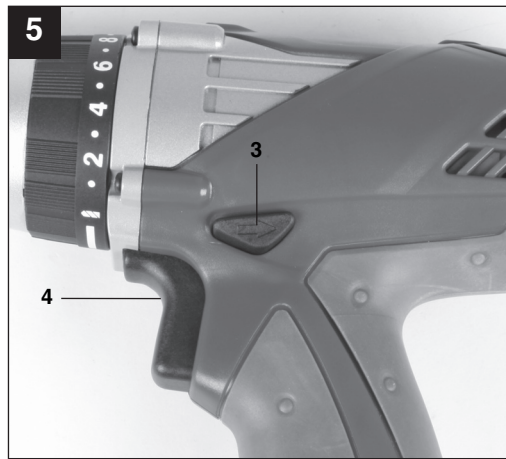
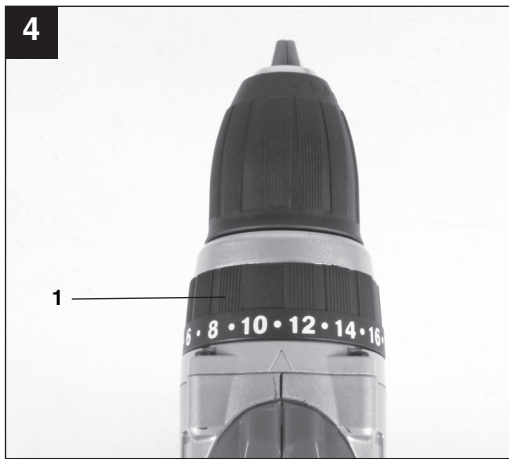



“Caution - Read the operating instructions to reduce the risk of injury”



Wear ear-muffs.

The impact of noise can cause damage to hearing.



Wear a breathing mask.

Dust which is injurious to health can be generated when working on wood and other materials. Never use the device to work on any materials containing asbestos!



Wear safety goggles.

Sparks generated during working or splinters, chips and dust emitted by the device can cause loss of sight.



Change the gear only when the drill is at a standstill. If you fail to observe this point, the gearing may be damaged.

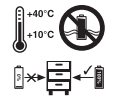

Store the battery only in dry rooms with an ambient temperature of +10°C to +40°C. Place only charged batteries in storage (charged at least 40%).

GB**⚠ Important!**

When using equipment, a few safety precautions must be observed to avoid injuries and damage. Please read the complete operating manual with due care. Keep this manual in a safe place, so that the information is available at all times. If you give the equipment to any other person, give them these operating instructions as well.

We accept no liability for damage or accidents which arise due to non-observance of these instructions and the safety information.

1. Safety information

Please refer to the booklet included in delivery for the safety instructions.

⚠ CAUTION!

Read all safety regulations and instructions. Any errors made in following the safety regulations and instructions may result in an electric shock, fire and/or serious injury. Keep all safety regulations and instructions in a safe place for future use.

2. Layout/Items supplied (Fig. 1)**2.1 Layout**

1. Torque selector
2. Battery capacity indicator
3. Changeover switch
4. ON/OFF switch
5. Battery pack
6. Battery charger
7. Selector switch for 1st/2nd gear
8. Pushlock button
9. Quick-change drill chuck
10. LED lamp
11. LED display for counter-clockwise/clockwise

2.2 Items supplied

- Open the packaging and take out the equipment with care.
- Remove the packaging material and any packaging and/or transportation braces (if available).
- Check to see if all items are supplied.
- Inspect the equipment and accessories for transport damage.
- If possible, please keep the packaging until the end of the guarantee period.

IMPORTANT

The equipment and packaging material are not toys. Do not let children play with plastic bags, foils or small parts. There is a danger of swallowing or suffocating!

- Cordless drill/screwdriver
- Battery charger
- 2 x Battery
- Original operating instructions
- Safety instructions

3. Proper use

The cordless drill/screwdriver is designed for tightening and undoing screws, as well as for drilling in wood, metal and plastic.

The machine is to be used only for its prescribed purpose. Any other use is deemed to be a case of misuse. The user / operator and not the manufacturer will be liable for any damage or injuries of any kind caused as a result of this.

Please note that our equipment has not been designed for use in commercial, trade or industrial applications. Our warranty will be voided if the machine is used in commercial, trade or industrial businesses or for equivalent purposes.

4. Technical data

| | |
|------------------------------|--------------------------|
| Battery | 5 cells Li-ion; 1500 mAh |
| Voltage supply | 18 V d.c. |
| Idling speed: | 0-320/0-1350 rpm |
| Torque settings: | 23+1 |
| Forward and reverse rotation | yes |
| Chuck clamping width | max. 10 mm |
| Battery charging voltage | 20 V d.c. |
| Battery charging current | 550 mA |
| Mains voltage for charger | 230 V ~ 50 Hz |
| Weight | 1.6 kg |
| Max. screw diameter: | 6 mm |

The maximum screw diameter indicates the maximum diameter of the screw that can be screwed into wood. The screw diameter can vary depending on the type of wood.

Sound and vibration

Sound and vibration values were measured in accordance with EN 60745.

| | |
|-------------------------------|------------|
| L_{pA} sound pressure level | 68.9 dB(A) |
| K_{pA} uncertainty | 3 dB |
| L_{WA} sound power level | 79.9 dB(A) |
| K_{WA} uncertainty | 3 dB |

Wear ear-muffs.

The impact of noise can cause damage to hearing.

Total vibration values (vector sum of three directions) determined in accordance with EN 60745.

Drilling in concrete

Vibration emission value $a_h \leq 2,5 \text{ m/s}^2$

K uncertainty = 1,5 m/s^2

Screwing without hammer action

Vibration emission value $a_h \leq 2,5 \text{ m/s}^2$

K uncertainty = 1,5 m/s^2

Additional information for electric power tools

Warning!

The specified vibration value was established in accordance with a standardized testing method. It may change according to how the electric equipment is used and may exceed the specified value in exceptional circumstances.

The specified vibration value can be used to compare the equipment with other electric power tools.

The specified vibration value can be used for initial assessment of a harmful effect.

Keep the noise emissions and vibrations to a minimum.

- Only use appliances which are in perfect working order.
- Service and clean the appliance regularly.
- Adapt your working style to suit the appliance.
- Do not overload the appliance.
- Have the appliance serviced whenever necessary.
- Switch the appliance off when it is not in use.
- Wear protective gloves.

Residual risks

Even if you use this electric power tool in accordance with instructions, certain residual risks cannot be ruled out. The following hazards may arise in connection with the equipment's construction and layout:

1. Lung damage if no suitable protective dust mask is used.
2. Damage to hearing if no suitable ear protection is used.
3. Health damage caused by hand-arm vibrations if the equipment is used over a prolonged period or is not properly guided and maintained.

Limit the operating time.

All stages of the operating cycle must be considered (for example, times in which the electric tools are switched off and times in which the tool is switched on but operates without load).

5. Before starting the equipment

Be sure to read the following information before you use your cordless screwdriver for the first time:

1. Charge the battery pack with the charger supplied. An empty battery pack requires a charging period of approximately 3-5 hours.
2. Only ever use sharp drill bits and screwdriver bits which are suitable for the purpose and in faultless condition.
3. Always check for concealed electric cables and gas and water pipes when drilling and screwing in walls.

6. Operation

6.1 Charging the LI battery pack (Fig. 2-3)

1. Remove the battery pack (5) from the handle, pressing the pushlock buttons (8) downwards to do so.
2. Check that your mains voltage is the same as that marked on the rating plate of the battery charger. Plug the mains plug of the charger (6) into the mains socket outlet. The red and green LEDs will come on together for approximately 1 second.
3. Push the battery into the battery charger. The flashing green LED will come on to indicate that the battery is being charged. When the charging process is finished, the green LED will be permanently lit. The time it takes to fully recharge an empty battery is approximately 3 to 5 hours. The temperature of the battery may rise slightly during the charging operation. This is normal. If

the red LED flashes after the battery has been inserted, the battery is defective. In this case, pull out the mains plug of the charger immediately and remove the defective battery. Do not use the defective battery again. If the red LED on the charger lights up while the battery pack is inserted, the charging temperature is either too high or too low. In this case, pull out the mains plug of the charger and charge the battery in an environment in which the temperature is either warmer or colder.

If the battery pack fails to become charged, please check

- whether there is voltage at the socket-outlet
- whether there is proper contact at the charging contacts on the charger.

If the battery still fails to become charged, please return

- the charger
 - the battery pack
- to our Customer Service Department.

To ensure that the LI battery pack provides long service you should take care to recharge it promptly. You must recharge the battery pack when you notice that the power of the cordless screwdriver drops.

6.2 Torque setting (Fig. 4 / Item 1) **Important! The tool must be at a standstill when you set the torque with the setting ring.**

The cordless screwdriver is fitted with a mechanical torque selector.

The torque for a specific size of screw is selected with the set-collar (1). The correct torque depends on several factors:

- on the type and hardness of material in question
- on the type and length screws used
- on the requirements needing to be met by the screwed joint.

The clutch disengages with a grating sound to indicate when the set torque is reached.

6.3 Drilling (Fig. 4 / Item 1)

For drilling purposes, move the set-collar to the last step „Drill“. In this setting the slip clutch is inactive. The maximum torque is available in drilling mode.

6.4 Forward/Reverse switch (Fig. 5 / Item 3)

With the slide switch above the On/Off switch you can select the direction of rotation of the battery-powered drill/screwdriver and secure it against being switched on accidentally. You can choose between clockwise and anticlockwise rotation. To avoid causing damage to the gearing it is advisable to change the direction of rotation only when the tool is at a standstill. The On/Off switch is blocked when the slide switch is in centre position.

6.5 On/Off switch (Fig. 5 / Item 4)

Infinitely variable speed control is possible with the On/Off switch. The further you press the switch, the higher the speed of the battery-powered drill/screwdriver.

6.6 Changing over from 1st gear to 2nd gear (Fig. 6 / Item 7)

You can work at a higher or lower speed depending on the position of the selector switch. To avoid damaging the gear unit you should only change over gears when the tool has stopped.

6.7 Battery capacity indicator (Fig. 7 – Item 2)

Press the battery capacity indicator switch (a). The battery capacity indicator (2) shows the charge status of the battery using 3 LEDs.

All 3 LEDs are lit:
The battery is fully charged.

2 LEDs are lit:
The battery has an adequate remaining charge.

1 LED is lit:
The battery is empty, recharge the battery.

6.8 LED lamp (Fig. 7 / Item 10)

The LED lamp (10) can be used in poor lighting conditions to illuminate the area where you want to drill or screw. The LED lamp (10) will be lit automatically as soon as you press the ON/OFF switch (4).

6.9 Changing the tool (Fig. 8)

Important. Set the changeover switch (3) to its centre position whenever you carry out any work (for example changing the tool, maintenance work, etc.) on the cordless screwdriver.

- The cordless screwdriver is fitted with a quick-action chuck (9) with an automatic spindle stop.
- Open the chuck (9). The chuck opening (a) must be large enough to hold the tool (drill bit or screwdriver bit).
- Select the suitable tool. Push the tool as far as

possible into the chuck opening (a).

- Tighten the chuck (9) and then check that the tool is secure.

6.10 Screwdriving

We recommend using self-centering screws (e.g. Torx screws, recessed head screws) designed for reliable working. Be sure to use a bit that matches the screw in shape and size. Set the torque, as described elsewhere in these operating instructions, to suit the size of screw.

6.11 LED display for clockwise/counter-clockwise operation (Figure 6/Item 11)

The LED display for counter-clockwise/clockwise (11) indicates the position of the changeover switch (3).

Green LED (11a) is lit: clockwise

Red LED (11b) is lit: counter-clockwise

7. Cleaning, maintenance and ordering of spare parts

Always pull out the mains power plug before starting any cleaning work.

7.1 Cleaning

- Keep all safety devices, air vents and the motor housing free of dirt and dust as far as possible. Wipe the equipment with a clean cloth or blow it with compressed air at low pressure.
- We recommend that you clean the device immediately each time you have finished using it.
- Clean the equipment regularly with a moist cloth and some soft soap. Do not use cleaning agents or solvents; these could attack the plastic parts of the equipment. Ensure that no water can seep into the device.

7.2 Maintenance

There are no parts inside the equipment which require additional maintenance.

7.3 Ordering replacement parts

Please quote the following data when ordering replacement parts:

- Type of machine
- Article number of the machine
- Identification number of the machine
- Replacement part number of the part required

8. Disposal and recycling

The unit is supplied in packaging to prevent its being damaged in transit. This packaging is raw material and can therefore be reused or can be returned to the raw material system.

The unit and its accessories are made of various types of material, such as metal and plastic. Defective components must be disposed of as special waste. Ask your dealer or your local council.

9. Storage

Store the equipment and accessories out of children's reach in a dark and dry place at above freezing temperature. The ideal storage temperature is between 5 and 30 °C. Store the electric tool in its original packaging.



GB GUARANTEE CERTIFICATE

Dear Customer,

All of our products undergo strict quality checks to ensure that they reach you in perfect condition. In the unlikely event that your device develops a fault, please contact our service department at the address shown on this guarantee card. Of course, if you would prefer to call us then we are also happy to offer our assistance under the service number printed below. Please note the following terms under which guarantee claims can be made:

1. These guarantee terms cover additional guarantee rights and do not affect your statutory warranty rights. We do not charge you for this guarantee.
2. Our guarantee only covers problems caused by material or manufacturing defects, and it is restricted to the rectification of these defects or replacement of the device. Please note that our devices have not been designed for use in commercial, trade or industrial applications. Consequently, the guarantee is invalidated if the equipment is used in commercial, trade or industrial applications or for other equivalent activities. The following are also excluded from our guarantee: compensation for transport damage, damage caused by failure to comply with the installation/assembly instructions or damage caused by unprofessional installation, failure to comply with the operating instructions (e.g. connection to the wrong mains voltage or current type), misuse or inappropriate use (such as overloading of the device or use of non-approved tools or accessories), failure to comply with the maintenance and safety regulations, ingress of foreign bodies into the device (e.g. sand, stones or dust), effects of force or external influences (e.g. damage caused by the device being dropped) and normal wear resulting from proper operation of the device.

The guarantee is rendered null and void if any attempt is made to tamper with the device.

3. The guarantee is valid for a period of 2 years starting from the purchase date of the device. Guarantee claims should be submitted before the end of the guarantee period within two weeks of the defect being noticed. No guarantee claims will be accepted after the end of the guarantee period. The original guarantee period remains applicable to the device even if repairs are carried out or parts are replaced. In such cases, the work performed or parts fitted will not result in an extension of the guarantee period, and no new guarantee will become active for the work performed or parts fitted. This also applies when an on-site service is used.
4. In order to assert your guarantee claim, please send your defective device postage-free to the address shown below. Please enclose either the original or a copy of your sales receipt or another dated proof of purchase. Please keep your sales receipt in a safe place, as it is your proof of purchase. It would help us if you could describe the nature of the problem in as much detail as possible. If the defect is covered by our guarantee then your device will either be repaired immediately and returned to you, or we will send you a new device.

Of course, we are also happy offer a chargeable repair service for any defects which are not covered by the scope of this guarantee or for units which are no longer covered. To take advantage of this service, please send the device to our service address.

EINHELL AUSTRALIA PTY LTD
6/166 Wellington Street
Collingwood VIC 3066
Australia
Phone: 1300 922 271

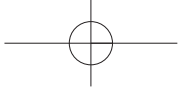

EH 06/2010 (02)

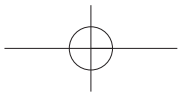

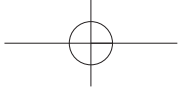

EH 06/2010 (02)

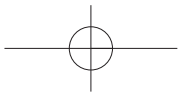

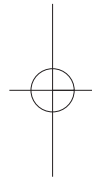
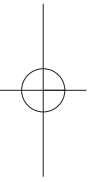
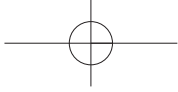

EH 06/2010 (02)

